

# **Nexstim NBS System 4 User Manual**

---

© Nexstim Oy. All rights reserved. Reproduction in any part without the written permission of Nexstim Oy is prohibited.

This document contains copyrighted information and is intended for the exclusive use of Nexstim customers. Copying, disclosure to others or other use is strictly prohibited without the express written authorization of Nexstim. Report any violations to Nexstim.

Nexstim reserves the right to make changes in any specifications shown herein at any time without notice or obligation. All specifications are for information only.

Nexstim<sup>®</sup> and NexSpeech<sup>®</sup> are registered trademarks of Nexstim Oy in the EU, USA and certain other countries. All other trademarks are the property of their respective owners.

US patent numbers: 6,256,531 6,849,040 7,854,232 7,998,053

Please address inquiries regarding this document or the device described herein to the manufacturer:

Nexstim Oy, Elimäenkatu 9 B, FIN-00510 Helsinki, Finland  
Tel: +358-9-2727-1710, Fax: +358-9-2727-1717

Nexstim Inc., 1360 Union Hill Road, Suite 3C, Alpharetta, GA  
Tel: (770) 664-1000, Fax: (770) 664-1217

[www.nexstim.com](http://www.nexstim.com)

E-mail: [support@nexstim.com](mailto:support@nexstim.com)

Printed in Finland, 5 September 2012. Document: NX81491-B.



## Table of contents

<b>1. Introduction.....</b>	<b>7</b>
1.1 Purpose of the document .....	8
1.2 Terms and abbreviations .....	9
1.3 Labels and symbols .....	10
<b>2. Intended use and safety .....</b>	<b>13</b>
2.1 Intended use .....	13
2.2 Contraindications .....	13
2.3 Limitations for use .....	14
2.4 Patient and user safety .....	14
<b>3. Nexstim NBS System technology and features.....</b>	<b>17</b>
3.1 Fundamentals .....	17
3.2 Components and features .....	17
3.2.1 Nexstim NBS .....	18
3.2.2 Nexstim TMS II Stimulator .....	19
3.2.3 Nexstim EMG .....	19
3.3 Nexstim NBS System accuracy .....	20
3.3.1 System accuracy .....	20
3.3.2 Accuracy of Nexstim NBS System based on comparison with DCS in tumor patients .....	21
<b>4. Hardware devices.....</b>	<b>23</b>
4.1 NBS cart .....	25
4.2 Nexstim TMS II Stimulator .....	26
4.3 Stimulation coil .....	27
4.3.1 Plugging in the stimulation coil .....	28
4.3.2 Holding the stimulation coil .....	29
4.4 Polaris tracking system .....	30
4.4.1 Positioning the Polaris Vicra tracking unit .....	31
4.4.2 Assessing the tracking unit positioning .....	32
4.5 Nexstim tracking tools .....	32
4.5.1 Coil tracker .....	33
4.5.2 Digitizing pen .....	33
4.5.3 Adjustable head tracker .....	33
4.6 NBS computer .....	35
4.7 Foot switch .....	36
4.8 Coil suspension arm .....	36
4.9 Nexstim EMG .....	37
4.9.1 Nexstim EMG amplifier .....	37
4.9.2 Nexstim EMG power unit .....	38
4.9.3 EMG electrodes .....	39
4.10 Registration sticker .....	41
4.11 Optional Nexstim NBS System parts .....	41
4.11.1 Nexstim Cooled Coil .....	41
4.11.2 Nexstim cooling unit .....	41
4.11.3 Patient chair .....	42
4.11.4 Standard head tracker .....	43
4.11.5 Coil positioning holder .....	43
4.11.6 Coil storage holder .....	44

<b>5. Nexstim NBS graphical user interface .....</b>	<b>45</b>
5.1 NBS session controls .....	46
5.2 Navigation and display controls .....	46
5.3 Session tree .....	48
5.4 MR images (2D images) .....	49
5.5 3D head .....	50
5.5.1 Peeling view .....	50
5.5.2 Cutting view .....	50
5.5.3 Visualized items on the 3D head .....	51
5.6 Electric field display .....	52
5.7 Aiming Tool .....	53
5.8 Info panel .....	54
5.9 Navigation-tab .....	55
5.9.1 Setting Stimulation target- dialog .....	56
5.10 Stimulation-tab .....	57
5.10.1 EMG-tab .....	58
5.10.2 Single pulse -tab .....	61
5.10.3 Repetitive-tab .....	68
5.11 Digitization-tab .....	73
5.12 Overlay-tab .....	74
5.12.1 Load DICOM export -tab .....	74
5.13 Settings-tab .....	76
5.13.1 Setup-tab .....	76
5.13.2 Status-tab .....	79
5.14 Graph Settings -tab .....	79
5.15 EMG display .....	81
5.16 Session file directories .....	82
<b>6. Using the Nexstim NBS software.....</b>	<b>83</b>
6.1 Prerequisites for using the NBS software .....	84
6.1.1 Handling MR images .....	84
6.2 Starting the NBS software .....	85
6.3 Closing the NBS software .....	86
6.4 Creating a new session .....	86
6.5 Opening a previously created session .....	89
6.6 Closing a stimulation session .....	89
6.7 Adjusting MR images on the NBS display .....	90
6.7.1 Adjusting, zooming, panning, and rotating the MR images .....	90
6.7.2 Selecting visualized items on the 3D head .....	92
6.8 Performing registration .....	92
6.8.1 Setting MRI landmarks .....	92
6.8.2 Digitizing nasion and ear landmarks on the scalp .....	95
6.8.3 Performing advanced registration .....	97
6.8.4 Verifying the registration .....	98
6.8.5 Creating reference points for registration integrity test .....	99
6.8.6 Performing the registration integrity test .....	100
6.8.7 Clearing the registration .....	101
6.9 Checking the coil tracker accuracy .....	102
6.10 Using Nexstim EMG .....	104
6.10.1 Performing EMG measurement .....	104
6.10.2 Adjusting Response Detection settings .....	105
6.10.3 Positioning and adjusting the EMG display windows .....	105



6.10.4	Defining the voltage level and time for EMG signals .....	105
6.10.5	Selecting display methods for EMG signals .....	106
6.10.6	Stimulating with EMG .....	107
6.10.7	Response Detection during stimulation .....	108
6.10.8	Correcting the EMG response parameters manually .....	108
6.10.9	Navigating continuous EMG signals .....	109
6.11	Performing stimulation .....	110
6.11.1	Creating and closing stimulation exams .....	110
6.11.2	Single-pulse stimulation .....	111
6.11.3	Defined series stimulation .....	112
6.11.4	Repetitive stimulation .....	113
6.11.5	Stimulation without navigation .....	114
6.11.6	Navigated stimulation .....	114
6.11.7	Setting the stimulation target .....	114
6.11.8	Stimulating to a stimulation target .....	116
6.11.9	Repeating the stimulus .....	117
6.11.10	Location controlled stimulation .....	118
6.12	Determining Motor Threshold .....	118
6.12.1	Starting MT determination from an MT exam .....	124
6.13	Using the session tree .....	125
6.13.1	Expanding and collapsing contents in the session tree .....	125
6.13.2	Selecting items in the session tree .....	125
6.13.3	Pop-up menus .....	125
6.14	Exporting session data .....	136
6.14.1	Exporting stimulation data to text file .....	139
6.14.2	Exporting digitization data to text file .....	139
6.14.3	Saving screenshots .....	139
6.15	Using analysis exams .....	140
6.15.1	Creating analysis exams .....	140
6.15.2	Activating and disabling analysis exams .....	140
6.15.3	Adding stimuli to analysis exam .....	140
6.15.4	Opening the Analysis Table .....	141
6.15.5	Selecting map types .....	146
6.16	Transferring session data to external systems using DICOM export .....	152
6.16.1	Generating DICOM export .....	153
6.16.2	Loading DICOM overlay export .....	156
6.16.3	Locating the color scale test icon in NBS .....	158
6.16.4	Adjusting the DICOM export color settings on third party systems .....	159
6.16.5	Capturing the DICOM screen .....	160
6.17	Using old session files .....	160
6.17.1	Backing up session files .....	161
6.17.2	Importing old session files .....	161
<b>7.</b>	<b>Examples of Nexstim NBS procedures.....</b>	<b>163</b>
7.1	Nexstim NBS session in detail .....	163
7.2	Mapping a specific muscle .....	166
7.2.1	Coil orientation and EMG responses in mapping .....	166
7.2.2	Example of mapping a specific muscle on a healthy subject .....	166
7.2.3	Example of multiple responses and multiple muscle mapping .....	169
<b>8.</b>	<b>Maintenance and care .....</b>	<b>171</b>
8.1	Cleaning .....	172

8.1.1 Cleaning the tracking system .....	172
8.2 Checking the stimulation coil pins .....	173
8.3 Changing the marker spheres .....	173
<b>9. Troubleshooting.....</b>	<b>175</b>
9.1 NBS does not recognize Nexstim TMS II .....	175
9.2 NBS application is slow .....	175
9.3 Lost license key .....	176
9.4 Duplicated NBS during startup .....	176
9.5 Red indicator light in the Nexstim TMS II front panel .....	176
9.6 The coil is overheated .....	177
9.7 Stimulation coil is old .....	177
9.8 Nexstim TMS II delivers no pulse .....	178
9.9 Tracking system does not see the tracker .....	179
9.10 Polaris tracking unit troubleshooting .....	179
9.11 Nexstim cooling unit troubleshooting .....	182
9.12 Registration problems .....	183
9.13 Targeting to a specific stimulation target is not possible .....	183
9.14 Electric field is not visible .....	184
9.15 EMG is not activated .....	184
9.15.1 EMG is not activated on start-up .....	184
9.15.2 Calibration fail .....	184
9.15.3 EMG connection failed .....	184
9.16 Inaccurate/no measurement in the EMG display .....	185
9.17 Inactive buttons in Single pulse stimulation -tab .....	186
9.18 Motor Threshold determination errors .....	186
9.18.1 Start-button in the Motor Threshold starting -dialog is inactive .....	186
9.18.2 MT determination process could not be started .....	187
9.18.3 MT determination process is interrupted .....	187
9.19 DICOM export errors .....	188
9.19.1 DICOM export failed -dialog appears .....	188
9.19.2 Original MR image not in DICOM format .....	188
9.19.3 Text export fails .....	189
9.19.4 MRI landmarks missing .....	189
9.19.5 Original MR image missing .....	189
9.19.6 Loading the meta data dictionary fails .....	190
<b>Appendix A: Technical specifications .....</b>	<b>191</b>
A.1 Nexstim NBS System.....	191
A.2 NBS cart.....	192
A.3 Nexstim TMS II Stimulator .....	192
A.4 Stimulation coils.....	193
A.5 Nexstim cooling unit.....	194
A.6 Isolation transformer.....	194
A.7 NBS computer.....	195
A.8 Polaris tracking system.....	195
A.9 Foot switch .....	196
A.10 Nexstim EMG.....	197
A.11 Registration sticker .....	197
A.12 Requirements for the external system .....	198
<b>Appendix B: Hardware connections.....</b>	<b>199</b>

B.1 Isolation transformer connections ..... 200

B.2 Nexstim TMS II connections..... 201

B.3 NBS computer connections ..... 201

B.4 Display connections..... 203

B.5 Nexstim EMG connections..... 204

B.6 Tracking system connections ..... 205

B.7 Cooling unit connections ..... 207

**Appendix C: Configuration example ..... 209**

**Appendix D: EMC emissions and immunity ..... 211**

**Appendix E: DICOM export ..... 217**

E.1 DICOM overlay export..... 217

    E.1.1 DICOM image file contents ..... 217

    E.1.2 DICOM overlay export visualization in Nexstim NBS ..... 222

E.2 DICOM text export contents ..... 233

**Appendix F: Electric field calculation ..... 241**

**References ..... 245**



# 1 Introduction

This document describes the Nexstim Navigated Brain Stimulation (NBS) System 4, software revision 4.3.

The Nexstim NBS System combines non-invasive transcranial magnetic stimulation (TMS) with MRI-based stereotactic navigation and simultaneous electromyography (EMG) measurement. NBS uses stereotactic localization of the Nexstim stimulation coil to interactively visualize the calculated effects of TMS stimulation and to guide TMS precisely over cortical motor areas. The Nexstim NBS System includes EMG, designed to non-invasively measure the motor evoked potentials (MEPs) elicited by TMS stimulation.



**Fig. 1.** Nexstim NBS System

The Nexstim NBS System is a fully integrated system that consists of the following components:

- Nexstim NBS software
- Nexstim TMS II Stimulator, and
- Nexstim Electromyography (EMG).

The NBS System is intended for use in clinical and research settings, by qualified medical personnel.

The individual components are not for use outside of the system, and they are always used together as one system. Nexstim TMS II and EMG cannot be used without the NBS software.

## 1.1 Purpose of the document

The purpose of this document is to describe the components and features of the Nexstim NBS System and to provide detailed instructions on the usage of the system.

---

**NOTE:**

Please make sure that all users of the Nexstim NBS System read these instructions and understand the conditions for safe use of the system. Failure to understand the information may lead to dangerous situations. We also recommend that you familiarize yourself with the Windows operating system before using the NBS computer.

Chapter 2 “Intended use and safety” includes important safety information about using the Nexstim NBS System.

---

For more information on the recommended safety and ethical guidelines, see Reference 3. under “References” on page 245.

This document does not include detailed use and maintenance instructions of the computer and its display. Please refer to the user manuals of the computer, display, and Windows operating system.

## 1.2 Terms and abbreviations

Table 1 describes the most commonly used terms in this document.

Table 1 Terms and abbreviations

Term	Description
Analyze format	Software package for multi-dimensional display, processing, and measurement of multi-modality biomedical images. It is used for medical tomographic scans from magnetic resonance imaging, computed tomography and positron emission tomography.
DCS	Direct Cortical Stimulation
DCS hotspot	Cortical location of the electric stimulation, which results in highest motor responses of a specific muscle during intraoperative DCS
DICOM	Standard by Digital Imaging and Communications in Medicine
EF (E-field)	Electric field
EMC	Electromagnetic compatibility
EMG	Electromyography
Hotspot	Location of the stimulus in the brain, that is, the maximum value of the electric field on the peeled brain surface.
Intensity	Percentage of the maximal stimulator output
MEP	Motor Evoked Potential; an excitatory response to TMS
Motor hotspot	Stimulation location eliciting the highest MEP in the muscle being monitored
MR image / MRI	Magnetic Resonance Imaging (or Image)
MT	Motor Threshold
NBS	Navigated Brain Stimulation
Nexstim NBS System	Fully configured Nexstim NBS system with NBS, TMS II, and EMG
NIfTI	Neuroimaging Informatics Technology Initiative. An Analyze-style data format to facilitate inter-operation of functional MRI data analysis software packages.
rTMS	Repetitive Transcranial Magnetic Stimulation <b>NOTE:</b> For use with NexSpeech only.
TMS	Transcranial Magnetic Stimulation

## 1.3 Labels and symbols

The following symbols are used in the product and documentation.

	<p>Warning / Precaution. Consult accompanying documents.</p> <p>In this manual, a warning is used to describe serious adverse reactions and potential safety hazards, limitations in use imposed by them, and steps that should be taken if they occur.</p> <p>A precaution is used to give information regarding any special care to be exercised by the operator and/or subject for the safe and effective use of the Nexstim NBS System.</p>		<p>CE mark according to Council Directive 93/42/EEC concerning medical devices</p>
	Power on		Power off
	Alternating current		TMS power on
	Type BF applied part		High voltages
	Protective earth (ground)		Earth (ground)
	Keep dry		Fragile
	Reference number		Serial number
	This side up		Electromagnetic radiation
	<p>Symbol according to European Community directive 2002/96/EC on Waste Electrical and Electronic Equipment (WEEE)</p>		<p>Dispensing prohibited without prescription. Federal law (USA) restricts this device to sale by or on the order of a physician.</p>
	Humidity limit		Atmospheric pressure limitation

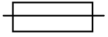




Temperature limitation/temperature range.  
Both upper and lower limits are indicated  
adjacent to horizontal lines.



Manufacturer



Fuse



Maximum load



## 2 Intended use and safety

This chapter contains guidelines and instructions to ensure safe and proper use of the Nexstim NBS System.

### 2.1 Intended use

The Nexstim Navigated Brain Stimulation System (NBS System) is indicated for non-invasive mapping of the primary motor cortex of the brain to its cortical gyrus. The NBS System provides information that may be used in the assessment of the primary motor cortex for pre-procedural planning. The NBS System is not intended to be used during a surgical procedure. The NBS System is intended to be used by trained clinical professionals.

### 2.2 Contraindications

Do not use the Nexstim NBS System on:

- persons who have metallic implants anywhere in the head (excluding teeth)
- persons who have any electrical implants
- persons with increased intracranial pressure
- persons with intracardiac lines, intravenous pumps, or dose calculators.

Do not use the Nexstim NBS System without clear benefit or compelling clinical reason on:

- persons with epilepsy
- persons with serious heart disease
- persons with lowered seizure threshold due to acute large infarctions, intracranial hemorrhage, or trauma
- persons with medication that lowers the seizure threshold
- persons with cardiac pacemaker.

Women of childbearing age must be questioned about the possibility of pregnancy before participating, and excluded if there is a chance that they may be pregnant. They should not participate without clinical reason.

The Nexstim NBS System should not be used by:

- operators who are pregnant
- operators with any electrical implants (such as cardiac pacemakers)
- operators with metallic implants anywhere in the upper body.

## 2.3 Limitations for use

---

**WARNING:**

Do not use the Nexstim NBS System in the presence of flammable gases and liquids.

Do not use the Nexstim NBS System at an Intensive Care Unit.

Do not use Nexstim NBS System near life maintaining and other sensitive devices.

Never supply power to Nexstim TMS II and life maintaining devices from the same outlet.

Never supply power to Nexstim TMS II from the same outlet with the Nexstim NBS System.

---

## 2.4 Patient and user safety

Please document any accident or injury to a subject, operator, or maintenance personnel that has occurred while using the Nexstim NBS System, and contact Nexstim immediately.

---

**WARNING:**

Do not use Nexstim TMS II during surgical procedures.

Do not use the Nexstim NBS System for intraoperative motor cortex localization, intraoperative localization of other eloquent cortex, or pre-operative localization for non-motor cortex.

Cortical magnetic stimulation runs the risk of inducing seizures; although they are rare. Single-pulse TMS, which is used in mapping the cortical representation areas of specific muscles, is generally considered a non-significant risk application. However, secondarily generalized or partial motor seizures have been induced in patients with stroke, intracranial brain lesions and major disorders of the central nervous system. The seizures have occurred either during the TMS or minutes after the end of the TMS session.

Because of the risk of seizures, Nexstim NBS System must not be used in persons with increased intracranial pressure. In persons with epilepsy, lowered seizure threshold due to acute large brain infarctions, intracranial hemorrhage or trauma, or in persons on medication that lowers seizure threshold, Nexstim NBS System should only be used when clear benefit or compelling clinical reason exists.

Subjects should be fully informed of the nature of all risks and of what will happen to them should a seizure occur.

---



## **WARNING:**

Appropriate seizure management procedures should always be in place when using the Nexstim NBS System. Safety procedures for acute seizure management can include but are not limited to the following site requirements when NBS System is used:

- presence of physician or nurse trained in seizure management;
- presence of or ready access to, life-support equipment (oxygen, suction, blood pressure monitor, intravenous equipment, cardiopulmonary resuscitation (CPR) equipment); and
- access to anti-seizure medications.

During TMS stimulation, there will be a clicking noise from the coil. The loudness correlates with the stimulation intensity. The noise may exceed the criteria limits for sensorineural hearing loss. Therefore, all persons should wear hearing protection (such as ear plugs) during stimulation. Also testing and maintenance personnel should wear hearing protections while working on the system.

Disconnect the subject from Nexstim EMG before using cardiac defibrillator or high frequency surgical equipment.

Always remove the coil from the subject's scalp immediately when you notice that the coil is overheated.

There is always a risk of inducing electrical current through leads that are in the proximity (closer than 20 cm (7.9 in)) of the stimulation coil. Be careful when using the Nexstim TMS II when there are leads connected directly to the subject.

Do not connect the patient to protective earth. Never touch the patient if touching simultaneously protective earth, such as any metal surface of Nexstim EMG or any other medical device.

To avoid the risk of electric shock, Nexstim NBS System must only be connected to a supply mains with protective earth.

Although the stimulation intensity may not be sufficient to elicit responses from all muscles and with every patient, it does not necessarily mean that the cortical area under stimulation coil is damaged or not functioning properly.



## **PRECAUTION:**

Grounding reliability can only be achieved when the Nexstim NBS System is connected to an equivalent receptacle marked hospital only or hospital grade.

To prevent unpredictable effects, only devices complying with safety standard 60601 are allowed in the patient environment.

All information the Nexstim NBS provides related to the intracranial position of the TMS stimulus with respect to the brain anatomy is only indicative. Confirm diagnostic or other findings with other examinations.

---



**PRECAUTION:**

Results of automatic analysis of motor evoked potentials (MEPs) must always be checked by qualified personnel.

---

**NOTE:**

When using the Nexstim NBS System on subjects who have scalp wounds or infections, avoid or protect the infected areas according to the best clinical practice.

It is recommended to use a standard questionnaire to screen the subject or patient for a history of head trauma, head surgery, seizures, implanted hardware, medications, neurological and medical illnesses, and a family history of epilepsy.

Mild headache is a frequent, but harmless side-effect of TMS stimulation. The reason for headache is probably the tension of scalp and neck muscles due to an uncomfortable and stressful situation.

TMS stimulation causes merely minor heating of the brain. The theoretical power dissipation from TMS is few milliwatts at 1 Hz. (In comparison, the brain's metabolic power is 13 W.)

---

# 3 Nexstim NBS System technology and features

This chapter describes the basic technology behind the Nexstim NBS System, as well as the features of the system.

## 3.1 Fundamentals

Navigated Brain Stimulation (NBS) combines precise MRI-based 3D localization with magnetic brain stimulation and simultaneous EMG measurement. Nexstim has combined these technologies into one system to provide NBS scanning as a new modality for brain mapping. NBS scanning facilitates continuous monitoring of the coil location, helping to target the stimuli to selected positions.

The image-guided method of NBS offers the possibility to predict which areas of the cerebral cortex are stimulated. NBS provides a link between the visible parts of the head (the scalp), and the not visible anatomical structures of the brain, as inferred from MR images. The linkage is based on an accurate 3D localization unit and advanced software.

## 3.2 Components and features

The Nexstim NBS System fully integrates the NBS, TMS, and EMG components of the system as shown in Figure 2.

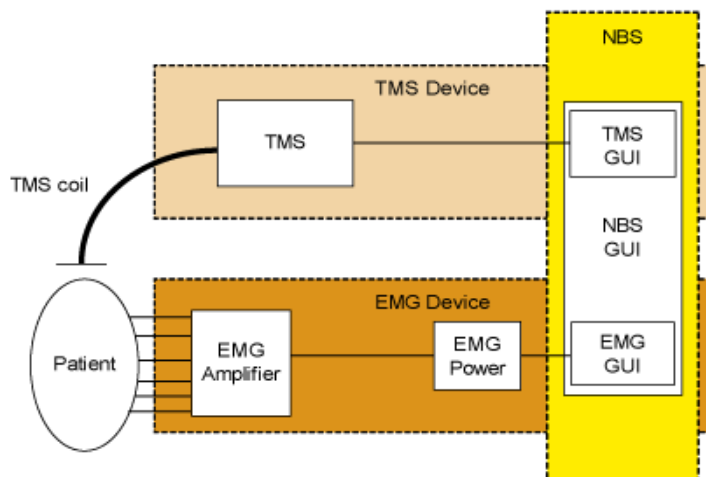


Fig. 2. Integrated Nexstim NBS System

### 3.2.1 Nexstim NBS

Navigated Brain Stimulation (NBS) combines MRI-based 3D localization with magnetic brain stimulation and simultaneous EMG measurement, including the following main features:

#### **Individual images loaded and aligned with the head**

Nexstim NBS software utilizes subject's MR images in generating an accurate 3D model of the actual head. This 3D model, when peeled, reveals the anatomical structures of the brain.

#### **Exporting of NBS results in DICOM (original MRI in DICOM format)**

The Nexstim NBS offers an export function, which allows the transfer of NBS results to external systems for pre-procedural planning.

NBS mapping results can be exported as DICOM image sets, containing NBS maps visualized in colors for third party systems. The 3D NBS view can also be captured in DICOM Secondary Capture format.

NBS-generated MRI sets will be tagged with appropriate DICOM information about the user, subject, and examination.

#### **Stimulating field**

Nexstim NBS System shows the intracranial electric field superimposed on the subject's anatomical MR images. In other words, the system helps to predict exact parts of the cerebral cortex the stimulation actually reaches, allowing accurate targeting of the maximum stimulation, the hotspot, into the examined cortical area.

#### **Stimulation targets**

Stimulation targets are the sites in the brain that the user wishes to stimulate. Nexstim NBS provides a targeting grid to assist in the accuracy of stimulation.

#### **Tracking**

The tracking system applies infrared light to measure the 3D position of marker spheres attached to trackers, which in turn are attached to the stimulation coil and to the subject's head.

#### **Automatic recording of stimulation data**

Nexstim NBS provides structured browsing of the distribution of the electric field and location of the peak electric field for each stimulus. Subject history is generated automatically for online and offline analysis.

#### **Accurate repetition of stimulus locations**

Nexstim NBS can accurately repeat the location of any navigated stimulus.



## **Location controlled stimulation**

Location controlled stimulation is used for repeating the conditions of a navigated stimulus.

## **Motor Threshold determination**

Nexstim NBS allows assisted determination of individual Motor Threshold (MT) for each subject.

## **Defined series stimulation**

Defined series are predefined stimulation programs, that is, series of single pulses. The interstimulus interval (ISI) and stimulus intensity may vary from stimulus to stimulus. Defined series can be used to generate, for example, information needed for recruitment curves of individual muscles in a fast and user-friendly manner.

### **3.2.2 Nexstim TMS II Stimulator**

Nexstim TMS II Stimulator is designed for focused non-invasive stimulation of the human brain. The brain is stimulated by using a pulse of magnetic field to cause current to flow in the brain tissue. The stimulated area is normally 2-3 cm (7.9-11.9 in) deep from the brain surface. The shape of the stimulated area varies due to the brain structure and the positioning of the stimulation coil over the head.

The pulse generation circuitry contains a discharge capacitor and a coil. The capacitor is first charged and then quickly discharged through the coil. This results in a strong current pulse.

Nexstim TMS supports biphasic stimulation waveform. Biphasic pulse is one cycle of an exponentially decaying sine pulse. Nexstim TMS II is always used as a part of the Nexstim NBS System, and cannot be used without Nexstim NBS software.

### **3.2.3 Nexstim EMG**

Electromyography (EMG) is a technique to measure the action potential from muscle fibres. The Nexstim EMG includes six EMG channels for measuring the motor evoked potentials (MEPs) of up to six muscles. Nexstim EMG is operated through Nexstim NBS, which automatically records the exact position of the stimulation coil and the strength of the stimulating electric field for each stimulus pulse and the motor-evoked potentials (MEPs) to the stimulus pulse in question.

Nexstim EMG is always used as a part of the Nexstim NBS System and cannot be used without Nexstim NBS software.

## 3.3 Nexstim NBS System accuracy

This chapter gives an overview of the Nexstim NBS System accuracy.

### 3.3.1 System accuracy

The NBS System accuracy is defined as the expected ability of the system to locate the position of the neurons in the brain whose stimulation results in motor-evoked potentials (MEPs) recorded from the surface of a specific muscle. In other words, the system accuracy is the uncertainty in the 3D coordinates of the identified muscle representation area with respect to the anatomical MR images.

The system accuracy can be assessed by identifying and quantifying the different factors that contribute to the accuracy, and then calculating the resulting total accuracy. The main sources of uncertainty are listed in Table 2.

Table 2 reports the contribution of each group of system localization error to the system localization (mapping) accuracy.

Table 2 System accuracy error groups

Error group	Error source
Group 1: Localization of the coil, optical tracking	<ul style="list-style-type: none"> <li>• Optical tracking of the coil</li> <li>• Manufacturing tolerances for the coil and trackers</li> <li>• Head tracker movement</li> </ul>
Group 2: Registration	<ul style="list-style-type: none"> <li>• MR image quality and resolution</li> <li>• Registration algorithm</li> <li>• Pinpointing of landmarks using the digitizing pen</li> </ul>
Group 3: Electromagnetic field modeling	<ul style="list-style-type: none"> <li>• Fitting of the conductor model to the head shape</li> <li>• Modeling the coil</li> <li>• Head conductor model</li> </ul>

## 3.3.2 Accuracy of Nexstim NBS System based on comparison with DCS in tumor patients

The accuracy of Nexstim NBS System in clinical use has been evaluated by comparing the localization of cortical representation areas of individual muscles obtained non-invasively by the NBS System in patients with brain tumors to the corresponding locations obtained invasively during surgery by direct cortical stimulation (DCS).

DCS was used as the method of reference as it is considered the gold standard for functional mapping of the motor cortex, and since it provides direct information of the cortical areas connected to peripheral muscles by corticospinal tracts. DCS and NBS both activate cortical neurons with a depolarizing electric field. The DCS electrodes are in direct physical contact with the target cortex surface. The electrode locations can be accurately determined using a neuronavigation system.

A total of 53 muscles in 23 patients were included in the analysis comparing NBS to DCS. In all 23 patients the pre-operative use of NBS resulted in the localization of the primary motor cortex (M1) to the same gyrus as determined intraoperatively by DCS. In 52 of the 53 muscles (98,1%) the cortical locations eliciting muscle representation areas were located in the same anatomical gyrus by both methods. For the one muscle where the motor areas determined by NBS and DCS were not located in the same gyrus, the area identified by NBS was one gyrus posterior to the area identified by DCS. However, based on the location of all the muscles mapped, also in this patient NBS and DCS results localized the M1 to the same gyrus.

Based on the results of the study, pre-operative NBS localizes the primary motor cortex to the same gyrus as intraoperative DCS.

It is recommended that the location of more than one muscle is determined during an NBS examination. Especially in cases where cortical anatomy is unclear or the NBS localization of one or more muscles is unexpected, the stimulation and localization of several muscles as well as the extent of their representation areas in addition to the location of the maximal responses or motor hotspots may provide additional information beneficial for determining the location of motor cortex in relation to the tumor.



## 4 Hardware devices

This chapter describes the Nexstim NBS System hardware. The system setup is illustrated in Figure 3. The numbered items in the figure are explained in Table 3.



**Fig. 3.** Nexstim NBS System setup

Table 3 Nexstim NBS System components

Item	Nexstim NBS System component	Described in Chapter
1	Coil suspension arm	4.8 “Coil suspension arm”
2	Polaris Tracking system	4.4 “Polaris tracking system”
3	NBS computer system (including mouse, keyboard, NBS software, license key, NBS and EMG displays)	4.6 “NBS computer” 5 “Nexstim NBS graphical user interface” 5.15 “EMG display”
4	NBS cart	4.1 “NBS cart”

Table 3 Nexstim NBS System components

Item	Nexstim NBS System component	Described in Chapter
5	Digitizing pen	4.5.2 “Digitizing pen”
6	Stimulation coil and coil tracker	4.3 “Stimulation coil”
7	Adjustable head tracker	4.5.3 “Adjustable head tracker”
8	Nexstim cooling unit (optional, for Nexstim Cooled Coil)	4.11.2 “Nexstim cooling unit”
9	TMS II Stimulator	4.2 “Nexstim TMS II Stimulator”
10	EMG electrodes	4.9.3 “EMG electrodes”
11	Patient chair	4.11.3 “Patient chair”
12	Nexstim EMG	4.9 “Nexstim EMG”
13	Foot switch	4.7 “Foot switch”

Additional parts delivered with the product are the following:

- This document
- Marker spheres
- Training set-up that consists of a styrox foam dummy head and a corresponding MRI image stack to be used with the dummy head
- Registration stickers (See Chapter 4.10.)

For optional NBS System parts, refer to Chapter 4.11 on page 41.



**PRECAUTION:**

Do not place anything liquid near the Nexstim NBS System.

To ensure normal operation, do not use any part of the Nexstim NBS System adjacent or stacked with any device.

Electrical equipment for medical uses requires special EMC precautions and needs to be installed and serviced according to the EMC documentation of the device.

Portable and mobile RF equipment can affect electrical equipment for medical use.

---

**NOTE:**

Ensure safe access to the Nexstim NBS System at all times by positioning power cords close to the walls.

---

## 4.1 NBS cart

The NBS cart is a flexible and mobile stand for the Nexstim NBS System, which can be used either with patient chair or bed. The cart integrates the following system parts (all individually described later in this manual):

- Nexstim TMS II Stimulator
- Arm-supported stimulation coil with coil tracker
- Arm-mounted Polaris tracking unit
- Nexstim EMG power unit
- NBS computer with two displays
- Foot switch
- Nexstim cooling unit (option, for Nexstim Cooled Coil).



### PRECAUTION:

Do not place any other devices than the pre-installed Nexstim NBS System parts in the NBS cart.

---



Fig. 4. NBS cart

**NOTE:**

Before moving the NBS cart, ensure that all NBS System parts are firmly mounted in the cart and the wheel breaks are released.

Walk slowly when moving the NBS cart. Do not transport the cart on ramps inclined at angle over 10 °.

## 4.2 Nexstim TMS II Stimulator

Nexstim TMS II Stimulator is integrated in the NBS cart (see Figure 4).

Nexstim TMS II delivers a magnetic stimulus to the targeted stimulation area to induce an electric field at the stimulation site. Operation of the Nexstim TMS II is controlled by the NBS software. A stimulus is delivered by pressing the foot switch or via the NBS graphical user interface (GUI).

Nexstim TMS is capable of delivering both single pulses and rTMS bursts.<sup>1</sup>

The TMS II front panel contains the stimulation coil connector, main power switch, and the indicator lights.



**Fig. 5.** TMS II Stimulator front panel

Table 4 TMS II Stimulator front panel description

1	Yellow indicator light	The yellow light is on when there are high voltages in the TMS II Stimulator.
2	Red indicator light	The red indicator light is on when there is an error situation in the system.
3	Stimulation coil connector	Connects the stimulation coil.
4	Green indicator light	The green light is on when the TMS II power is on.
5	Main power switch	Turn on/off the TMS II.

1. The rTMS feature is for use with NexSpeech only.





**WARNING:**

Do not use Nexstim TMS II if there are any signs of external damage or if any parts are damp or wet.

---



**PRECAUTION:**

If the red indicator light is on, immediately discontinue use and restart the stimulator.

If the red indicator light stays on despite several attempts to restart the system, contact your local Nexstim representative or Nexstim technical support.

If the yellow indicator light is on, never unplug the stimulation coil.

Nexstim TMS II is always used as a combined system with Nexstim NBS and Nexstim EMG. TMS II cannot be used without Nexstim NBS software.

Do not use Nexstim TMS II within 1 m (39.4 in) of objects sensitive to magnetic fields, such as credit cards or CD-ROM disks.

Do not trigger a stimulation pulse while the stimulation coil is in the immediate vicinity of any electrical device.

---

In addition, refer to Chapter B.2 “Nexstim TMS II connections” on page 201.

## 4.3 Stimulation coil

The standard Nexstim NBS System comprises the Nexstim Focal Coil.



**Fig. 6.** Nexstim Focal Coil

Nexstim Cooled Coil is offered as an option (see Chapter 4.11.1).

The coils are 8-shaped coils, which means that the strongest stimulus is delivered approximately below the center of the coil. The coils can be used for single-pulse and rTMS modes.<sup>1</sup>

The coil cable is fixed to the coil. In the other end of the coil cable is the coil connector that connects the coil to the TMS II front panel. The Nexstim coil tracker is attached to the coil and can be changed.

**WARNING:**

Do not place the stimulation coil near metal objects. There must be at least 20 cm (7.9 in) distance.

Do not place the stimulation coil near other electrical devices. There must be at least 1 m (39.4 in) distance.

The coil induces eddy currents in any conductive medium (such as the nearby metallic objects or electronic devices). The eddy currents can be strong enough to cause dangerous projections of metallic objects.

---

**PRECAUTION:**

Do not use water, ice, or refrigerator to cool the stimulation coil. Cooling must be performed by using only a flow of cool air from a fan, for example. Never immerse the stimulation coil into water.

---

### 4.3.1 Plugging in the stimulation coil

---

**PRECAUTION:**

Never unplug the stimulation coil if the yellow indicator light is on in the Nexstim TMS II.

Never use a coil on a stimulator with burnt socket pins; otherwise the coil will have its pins damaged immediately. Also, a socket with good pins that has a coil with burnt pins connected to it will have its pins damaged immediately.

Check the coil casing for any signs of damage (such as cracks).

If you notice burn damage on a coil connector or stimulator coil socket, do not use the system until all pins and sockets are carefully examined for any damage. If any contacts show damage, no matter how slight, they will need to be changed. If this is not done immediately, there is serious risk that the cycle of contact damage will continue. Contact your local Nexstim representative or Nexstim technical support for contact replacement.

---

1. The rTMS feature is for use with NexSpeech only.

1. Plug in the coil to TMS II Stimulator so that the flat part of the coil connector is facing upwards (see Figure 5 on page 26). Do not use force to put the coil connector in place.
2. Lock the coil by turning the coil plug to clockwise direction until it clicks to its place. The blue dot is now facing upwards.
3. Make sure that the stimulation coil is firmly plugged in before starting stimulation.

## 4.3.2 Holding the stimulation coil

Try to find the best ergonomic position so that holding the coil in place is comfortable. Stand close to the subject.

The coil itself is small and light to handle, but the bending coil cable may make the coil feel heavy to move in some positions. Holding the coil handle in one hand like a pen helps greatly in navigating the coil around the head to obtain optimal rotation.

Using the coil suspension arm diminishes the weight of the coil and cable (see Chapter 4.8 “Coil suspension arm” on page 36). When holding the coil, ensure that the coil cable is not bent, but remains straight. It is also advisable to support the casing of the coil with the other hand to take up the weight.



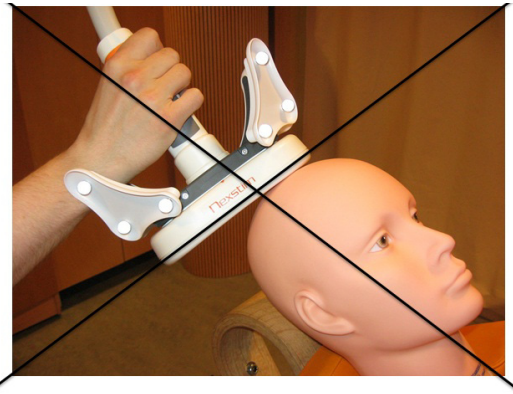
**Fig. 7.** Holding the stimulation coil

Nexstim TMS II uses the foot switch to deliver stimuli, which means that you can use both hands to position and hold the coil firmly in place. Keep the foot switch at your reach so that you do not need to move when delivering stimuli.

Position the coil so that the direction of the electric field is perpendicular to the sulcus of the stimulated area. See Figure 94, “Coil placement arrows, indicating direction of the stimulus pulse,” on page 117.

Let the coil touch the scalp and make sure that the center of the coil is over the area to be stimulated.

The following is a list of typical errors when using a stimulation coil. An example of how **not** to use the stimulation coil is illustrated in Figure 8.



**Fig. 8.** How NOT to use the coil

- The operator is standing far from the subject.
- The operator is holding the coil in one hand, the hand tight in a fist.
- The operator is not supporting the coil it with the free hand.
- The center of the coil is not directed on the area to be stimulated.

## 4.4 Polaris tracking system

The tracking system is mounted in the NBS cart (see Figure 4, “NBS cart,” on page 25).

The Polaris tracking system measures the position of the stimulation coil with respect to the subject’s head. The tracking unit applies infrared light to measure the 3D position of the reflective passive markers attached to the tracking tools (that is, head tracker, coil tracker, and digitizing pen). This enables the recording of real-time positions and orientations of each tracking tool. It also allows free movements of the subject’s head.



### **PRECAUTION:**

Avoid touching the tracking unit lens.

The tracking system is a very sensitive measurement device. Vibration and mechanical shocks may gradually deteriorate the field-of-view. In such case, extensive recalibration is needed. Contact your local Nexstim representative or Nexstim technical support when you need recalibration. (For example, a shrinking volume may induce need for recalibration; see the note below.)

The tracking system is sensitive to infra-red light. Minimize the sources of background IR in the 800 - 100 nm range (for example, sunlight).

**NOTE:**

A periodic functionality check of the tracking system is recommended. You can use the NBS tools (digitizing pen, head tracker) to verify that the measurement volume of the tracking system is within specifications.

Check the tracking system mounting regularly.

Ensure even operating temperature for the tracking system. Air conditioning may interfere with the very sensitive calibration of the tracking system.

Ensure that the lighting near the NBS System is adjustable (blinds, curtains, and/or lamps).

A shrinking volume may indicate loss of calibration or other problem with the tracking system. Also, a special Accuracy Assessment Kit is available. Contact your local Nexstim representative or Nexstim technical support for further information.

---

The tracking system is automatically turned on when the NBS cart is connected to the mains power. It takes a few minutes for the tracking system to warm up.

The front of the Polaris Vicra tracking unit incorporates the components as displayed in Figure 9.



**Fig. 9.** Polaris Vicra front view

The indicator LEDs on the front panel indicate the status of the Vicra tracking unit. For their description, see Chapter 9.10 “Polaris tracking unit troubleshooting” on page 179.

The rear of the tracking unit incorporates the mount and connector.

Refer to the NDI User Guides for more detailed information on the Polaris tracking system.

## 4.4.1 Positioning the Polaris Vicra tracking unit

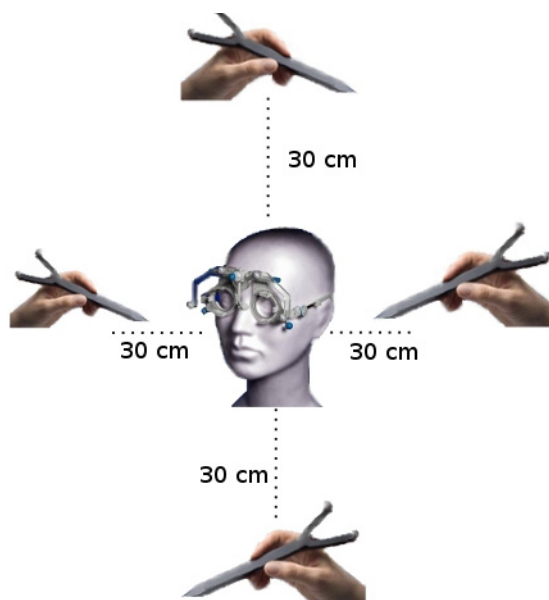
To adjust the Polaris Vicra positioning, grab the tracking unit handle and move the arm to desired position. The tracking unit should face the subject.

The optimum distance between the Polaris Vicra camera and the head tracker is 80-100 cm (31.5-39.4 in). For more information, see Figure 150 on page 196.

#### 4.4.2 Assessing the tracking unit positioning

Follow the instructions below to ensure that the digitizing pen and head tracker are easily seen by the tracking unit.

1. Move the digitizing pen around the head (20-30 cm (7.9-11.8 in) distance from the head) in four directions. Move the pen up and down, sideways, and back and forth. See Figure 10.
2. Ensure that the tracking unit indicator light on the NBS view turns green in all four directions (see Chapter 5.2 “Navigation and display controls” on page 46). If the light does not turn green, adjust the camera to better focus towards the subject’s forehead.



**Fig. 10.** Assessing the camera positioning

### 4.5 Nexstim tracking tools

The tracking system applies infrared light to measure the 3D position of the reflective passive markers attached to the tracking tools (that is, head tracker, coil tracker, and digitizing pen). This enables the recording of real-time positions and orientations of the tracker.

For instructions on how to change the Nexstim coil tracker markers, see Chapter 8.3 on page 173.



## PRECAUTION:

Check the trackers before every use. If a tracker falls on the floor, or it is twisted or bent, its usability, as well as the accuracy of the measurements may be reduced.

When handling the trackers, avoid touching the markers. To prevent grease marks, do not touch the markers with your fingers. Instead, wear disposable plastic or other clean gloves, or place a clean cloth between the markers and your fingers.

Do not put the trackers on a table with markers facing down. The retro-reflecting coating is easily rubbed off from the marker surface. If the coating wears off, the marker can no longer be used.

---

## 4.5.1 Coil tracker

Nexstim coil tracker allows the stimulation coil to be tracked online when a navigated stimulation session is run with Nexstim NBS. The coil tracker contains four elements of three reflective marker spheres, each attached to the stimulation coil (see Figure 6, “Nexstim Focal Coil,” on page 27).

## 4.5.2 Digitizing pen

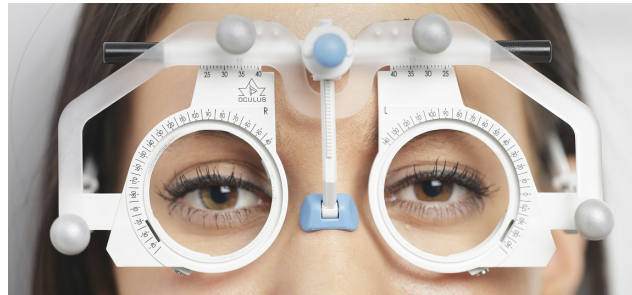
The Y-shaped digitizing pen, including three reflective marker spheres, is used for placing registration landmarks on the subject’s head, as well as to perform digitization.



Fig. 11. Digitizing pen

## 4.5.3 Adjustable head tracker

Adjustable head tracker is an ophthalmic trial lens frame with an attached tracker element. Four reflective sphere markers are strategically placed on the frame for tracking the location of the head with respect to the stimulation coil. The adjustable head tracker allows flexible and firm adjustment on all subjects and different head sizes.



**Fig. 12.** Adjustable head tracker

Also standard head tracker is available upon request (see Chapter 4.11.4 on page 43).

### Adjusting the adjustable head tracker on the subject's head

---

#### NOTE:

Always fit the adjustable head tracker firmly on the head.

---

1. Before placing the adjustable head tracker on the subject's head:
  - a) Try out the different adjustment options so that you are familiar with the head tracker.
  - b) Adjust the flexible side ends.
2. If the subject wears eyeglasses, ask him/her to remove them.
3. Place the head tracker on the subject's nose and adjust the side length by pushing in or pulling out the sides.

Notches prevent the sides from slipping out of position. The sides are designed so that no hair gets caught in them.

If the side length is too tight in the beginning, the adjustment becomes difficult.
4. Adjust the pupil distance: turn the blue knobs on the sides of the top frame so that the pupils are horizontally on the center of the lens frame.



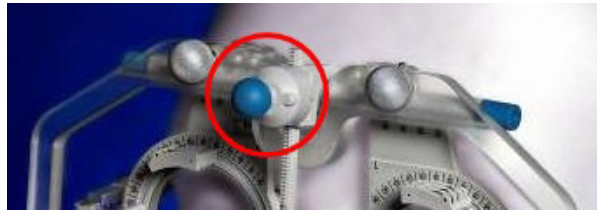
**Fig. 13.** Adjusting the pupil distance

5. Adjust the height of the nose pad:
  - a) Turn the blue knob on the front of the frame so that the nose pad firmly fits on the nose bridge.



b) Check also that the pupils are vertically on the center of the lens frame.

Make sure that the inside of the lens frame does not touch the subject's face. Only the nose pad should touch the face.



**Fig. 14.** Adjusting the height of the nose pad

**6.** Adjust the head tracker frame tilt:

a) Turn the knurled knobs on the sides of the frame. The frame tilt is correct when the frame is aligned with the eyes.

b) Check also that the frame does not lean heavily on the subject's cheekbone.

Check the head tracker frame tilt carefully from the side of the head.



**Fig. 15.** Adjusting the head tracker frame tilt

**7.** Adjust the side length again by pushing in or pulling out the sides.

The side length should be firm and comfortable. The subject should be able to see directly through the lens frame.

**8.** Adjust the flexible side ends:

a) To shorten the side length, tilt the side end so that it tightly fits the top of the ear.

b) To get more side length, straighten the side end.

**9.** Adjust the very tip of the side end so that it is smoothly against the scalp.

The tip of the side end may cause discomfort if it presses the back of the ear or the side of the head.

## 4.6 NBS computer

The NBS computer is supplied for use with two 20" flat screens:

- NBS display shows the navigation and TMS stimulation information, and
- EMG display shows the EMG data and evoked responses.

Furthermore, the NBS computer contains a mouse, a keyboard, an integrated DVD R/RW drive, and a licence key.

NBS computer uses Windows Vista Ultimate (32 bit) operating system. The PC is also loaded with the proprietary Nexstim NBS software, containing all the tools needed to perform navigated magnetic stimulation.

For information on the computer connections, see Chapter B.3 “NBS computer connections” on page 201.

---

**NOTE:**

Nexstim recommends restarting the NBS computer once a day.

---

## 4.7 Foot switch

The foot switch has three pedals with specific functionalities, depending on the selected NBS procedures.



**Fig. 16.** Foot switch

## 4.8 Coil suspension arm

Coil suspension arm is integrated in the NBS cart to provide support for holding the coil. The coil suspension arm can be rotated and is suited for all Nexstim coils.



**Fig. 17.** Coil suspension arm

---

**NOTE:**

When stimulating, ensure that the coil cable is never bent. Use the coil suspension arm to optimally position the stimulation coil, ensuring that the coil cable maintains straight.

---

## 4.9 Nexstim EMG

### 4.9.1 Nexstim EMG amplifier

---



**PRECAUTION:**

Nexstim EMG is always used as a combined system with Nexstim NBS and TMS II Stimulator. Nexstim EMG cannot be used without Nexstim NBS.

Do not place the EMG amplifier near isolation transformer or other devices, which may cause electromagnetic radiation and hence affect the signal quality.

---

Nexstim EMG amplifier detects the electrical potential generated by muscle cells when these cells contract. The measurement is performed from the skin surface by placing surface electrodes (see Chapter 4.9.3 “EMG electrodes” on page 39).



**Fig. 18.** Nexstim EMG amplifier

See also Chapter “EMG amplifier connections” on page 204.

## 4.9.2 Nexstim EMG power unit



### **PRECAUTION:**

Nexstim EMG is always used as a combined system with Nexstim NBS and TMS II Stimulator. Nexstim EMG cannot be used without Nexstim NBS.

---

Nexstim EMG power unit is integrated in the NBS cart. The power switch is located in the EMG power unit front panel.



**Fig. 19.** Nexstim EMG power unit

See also Chapter “EMG power unit connections” on page 205.

## 4.9.3 EMG electrodes

---



### PRECAUTION:

Do not place or connect the EMG electrodes or their connectors in contact with any conductive parts, such as metal plates or electric power outlets.

---

Nexstim EMG is used with disposable, pre-gelled, self-adhesive electrodes. The electrodes are connected to the EMG amplifier using the Nexstim EMG electrode cable.

The red electrode measures muscle response while the black electrode acts as measurement reference.

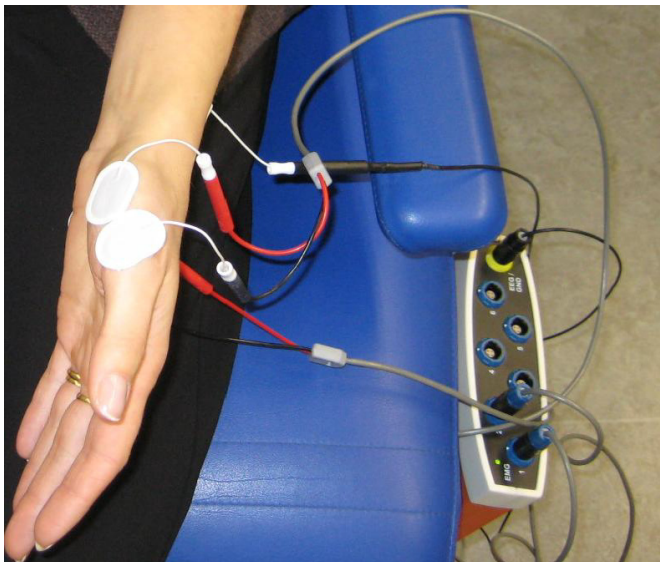


Fig. 20. Nexstim EMG electrodes

### Attaching EMG electrodes

---

#### NOTE:

It is recommended to use only the Ambu® Neuroline 720 self-adhesive electrodes model number 720 01-K. Electrodes must be attached to the Nexstim EMG electrode cable with a 1.5 mm touch-proof female safety connector (DIN 42-802).

Before attaching the electrodes, make sure that the adhesive paste inside the electrodes has not dried out.

If there are unused EMG channels, unplug those electrode cables in the EMG amplifier.

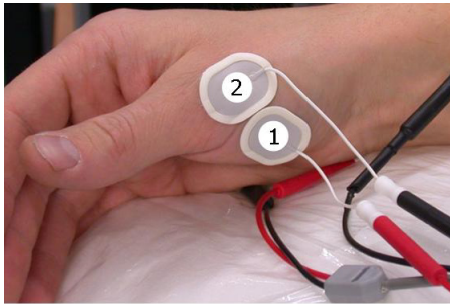
---

**NOTE:**

When attaching electrodes, do not push down on the center of the electrode to avoid the adhesive paste from running out from under the edges. Instead push down along the edges of the electrode.

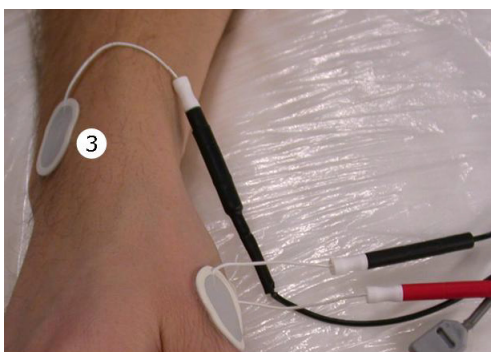
For correct mapping of motor areas, keep track of the connected electrodes and the corresponding channels when connecting the electrode cables to amplifier.

1. Clean the subject's skin with a disinfectant before attaching the electrodes.
2. Attach the red (measuring) electrode on the belly of the muscle being measured (see item 1 in Figure 21).
3. Attach the black (referencing) electrode over bone or cartilage near the muscle (see item 2 Figure 21).



**Fig. 21.** Attaching red and black electrodes (for identifying EMG responses for abductor pollicis brevis (APB))

4. Attach the grounding GND electrode over bone or other area of the body with no muscle (see item 3 in Figure 22).



**Fig. 22.** Attaching the GND electrode

To minimize interference in the EMG channels, try to attach the measuring and reference electrodes to similar skin, so that one electrode is not over thicker skin than the other. The best channel results are obtained 10-15 minutes after the electrodes have been attached to the subject.

## 4.10 Registration sticker

Registration sticker is fastened to the subject's forehead when performing digitization and the registration integrity test, which is used to observe the head tracker movement. (See chapters 6.8.5 "Creating reference points for registration integrity test" on page 99 and A.11 "Registration sticker" on page 197.)

## 4.11 Optional Nexstim NBS System parts

### 4.11.1 Nexstim Cooled Coil

Nexstim Cooled Coil is ideal for high-intensity pulse trains or long stimulation sessions, as it is air-cooled through the Nexstim cooling unit.



Fig. 23. Nexstim Cooled Coil

### 4.11.2 Nexstim cooling unit

Nexstim cooling unit ensures delivering sufficient air flow for the Nexstim Cooled Coil. The cooling unit is integrated in the NBS cart.



**Fig. 24.** Cooling unit for Nexstim Cooled Coil

---

**NOTE:**

Before every use of the Nexstim Cooled Coil, ensure that the air hoses are properly connected between the coil and cooling unit.

- Connect the blue-labeled air hose to the “Out” connector.
- Connect the red-labeled air hose to the “In” connector.

---

### 4.11.3 Patient chair

Nexstim patient chair is electronically controlled and can be adjusted into various seating positions. Adjustable head support is designed for comfortable head positioning during sessions. For more information, refer to the chair manufacturer’s documentation.



**Fig. 25.** Nexstim patient chair



#### 4.11.4 Standard head tracker

The standard head tracker is designed so that the subject can wear eyeglasses with the head tracker.

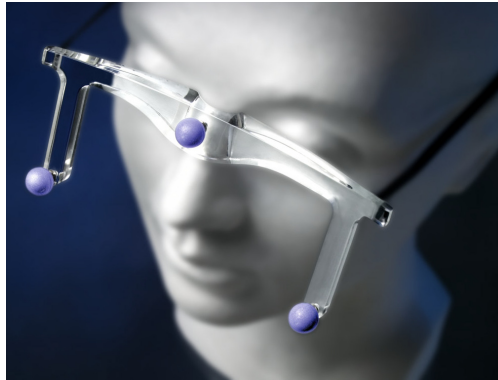


Fig. 26. Standard head tracker

#### Setting the standard head tracker on a subject's head

1. If the subject normally wears eyeglasses, ask him/her to put them on.
2. Attach a disposable nose pad under the nosepiece of the head tracker. Check that the head tracker fits on the subject's nose bridge.
3. Place the head tracker on the subject's nose, hold it in place, and pull the strap behind the subject's head.
4. Adjust the strap length, and place it so that it goes under the subject's ears and down onto the neck. The subject should be able to see over the standard head tracker.

#### 4.11.5 Coil positioning holder

The coil positioner is used for holding the stimulation coil in place when stimulating the patient.

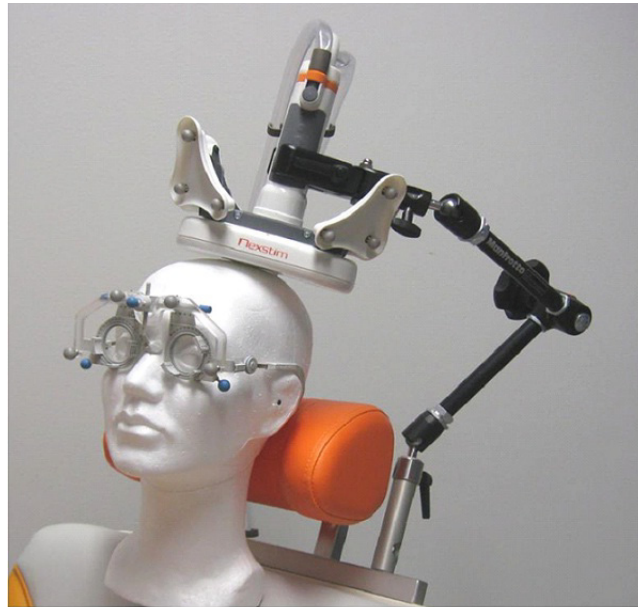


Fig. 27. Coil positioning holder

#### 4.11.6 Coil storage holder

The Nexstim stimulation coils can be stored safely in the NBS cart-mounted coil storage holder.

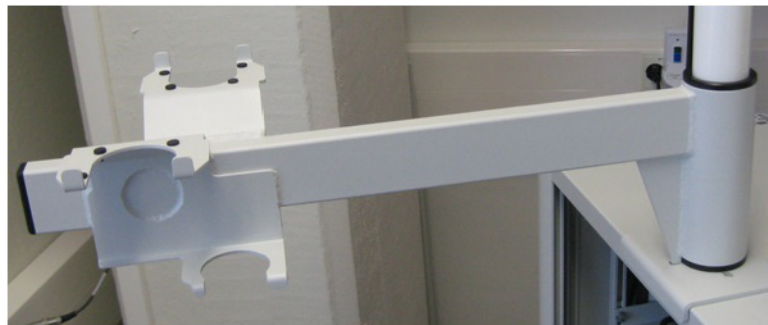


Fig. 28. Coil storage holder

## 5 Nexstim NBS graphical user interface

The main objective of the NBS software is to combine the ability to produce precise 3D visualization of electric field distribution with magnetic stimulation, thus providing tools for navigated TMS stimulation.

The NBS software utilizes a subject's MR-images to generate an accurate 3D-model of the subject's actual head. This 3D-model, when peeled, reveals the anatomical structures of the brain. The software contains algorithms to calculate and visualize the intracranial electric field superimposed on the anatomical structures of this 3D-model.

The Nexstim EMG and Nexstim TMS graphical user interfaces (GUIs) are fully integrated into the Nexstim NBS software, so that all controls and settings are managed through the main NBS GUI. EMG channels and responses to TMS stimulation are shown on a separate display. See Figure 29 and Table 5.

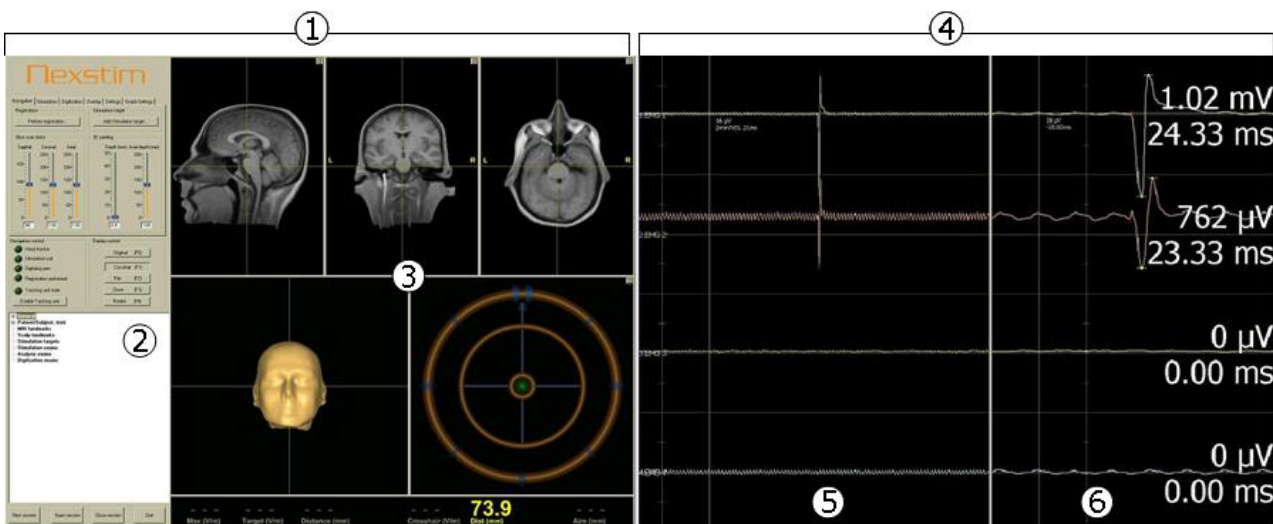


Fig. 29. Nexstim NBS System view

Table 5 Nexstim NBS System view description

Item	System view	Description
1	NBS display	This view is presented on a dedicated screen and contains all the controls for the Nexstim NBS System.
2	NBS System controls	The Nexstim NBS System is controlled via the session tabs, session tree pop-up menu, and control buttons, all described later in this chapter.
3	MR images, 3D head, Aiming Tool, and info panel	This view presents the MR images, the 3D head, and Aiming Tool. The lower part of the view contains the info panel
4	EMG display	This view is presented on a dedicated display, if available. If not, it can be viewed by selecting EMG view under <b>Graph settings</b> .

Table 5 Nexstim NBS System view description

Item	System view	Description
5	EMG continuous view	Displays continuous EMG data.
6	EMG epochs view	Displays EMG data at the point of a given stimulus.

The NBS software communicates with the Polaris tracking system position sensor and provides operational control of the Nexstim TMS II and Nexstim EMG, serves as the GUI for setting stimulation and EMG data display parameters, initiates TMS II stimulus delivery via the foot switch, and displays EMG data and motor evoked potential (MEP) responses.

In addition, the NBS software provides automatic recording of stimulation data, structured session documentation, and analysis of the collected information. The NBS software provides structured browsing of the electric field distribution and the location of the peak electric field for each stimulus.

## 5.1 NBS session controls

This chapter describes the NBS session controls, located at the bottom left corner of the NBS display.



Fig. 30. Session controls

Table 6 Nexstim NBS System view description

1	<b>New session</b>	Click to start a new session with no previous data. See Chapter 6.4 “Creating a new session” on page 86.
2	<b>Open session</b>	Click to continue a former NBS session for the same subject. See Chapter 6.5 “Opening a previously created session” on page 89.
3	<b>Close session</b>	Click to close the session.
4	<b>Quit</b>	Click to quit the NBS software. See Chapter 6.3 “Closing the NBS software” on page 86.

## 5.2 Navigation and display controls

The Navigation controls show the states of the tracking tools, and the Display controls are used to adjust the MR image views and the 3D head view.

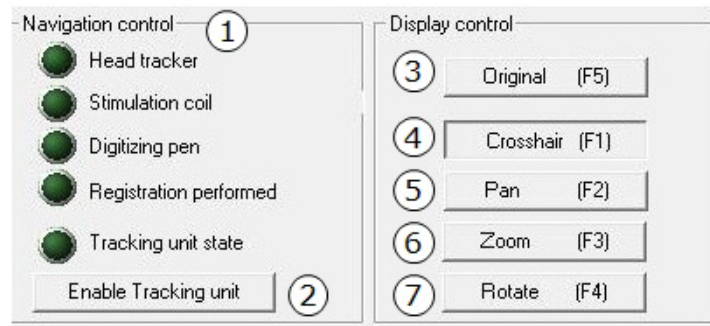


Fig. 31. Navigation and display controls

Table 7 Navigation and display control definitions

1	Navigation control	<p>Colored indicators appear bright green when the <b>Head tracker</b>, <b>Stimulation coil</b> and <b>Digitizing pen</b> are all visible to the tracking system. The head tracker must always be visible. If the head tracker is not visible, the indicators for digitizing pen and stimulation coil turn yellow when visible to the tracking system.</p> <p>The <b>Registration performed</b> indicator is green when registration has been successfully completed.</p> <p>The <b>Tracking unit state</b> indicators are:</p> <ul style="list-style-type: none"> <li>• Dark green: The system is off line.</li> <li>• Bright green: The system is functioning correctly.</li> <li>• Red: The tracking unit power is off or it has not been connected to the NBS computer.</li> <li>• Yellow: The exact location of the tracking tool is not clear.</li> </ul>
2	<b>Enable Tracking unit</b>	Click the <b>Enable Tracking unit</b> -button to activate the tracking unit and initialize the tracking tools.
3	<b>Original (F5)</b>	Select to return to the image default settings in all views.
4	<b>Crosshair (F1)</b>	Select and left-click on the MR views to browse the MR images. You can move between the MR images by rolling the centre mouse button.
5	<b>Pan (F2)</b>	Select to left-click and drag an image within its window.
6	<b>Zoom (F3)</b>	Select to zoom in and out of any image, left-click to zoom in and right-click to zoom out.
7	<b>Rotate (F4)</b>	Select to click and drag the 3D head image to rotate its viewing angle. Left and right-clicking provide different rotation functions.

Refer to Chapter 6.7 “Adjusting MR images on the NBS display” on page 90 for more instructions.

You can also press the relevant function button (F1-F5) at any time to manipulate the 2D and 3D views with the mouse.

## 5.3 Session tree

Session tree is a graphical treelike presentation of all the operations performed during a session. You can use it to browse earlier examinations and carry out different operations. Session-specific information about the subject, researcher and registration (physical and anatomical landmarks) are stored in the tree. In addition, navigation and stimulation results are stored in the stimulation and digitization exams under which the stimuli and digitization points are stored.

Items, which location is known (that is, can be visualized in the 3D head), have the postfix “(visible)” or “(not visible)”, depending on their visibility settings.

Active items are bolded in the session tree and have a prefix (e.g., “active” or “repeated”).

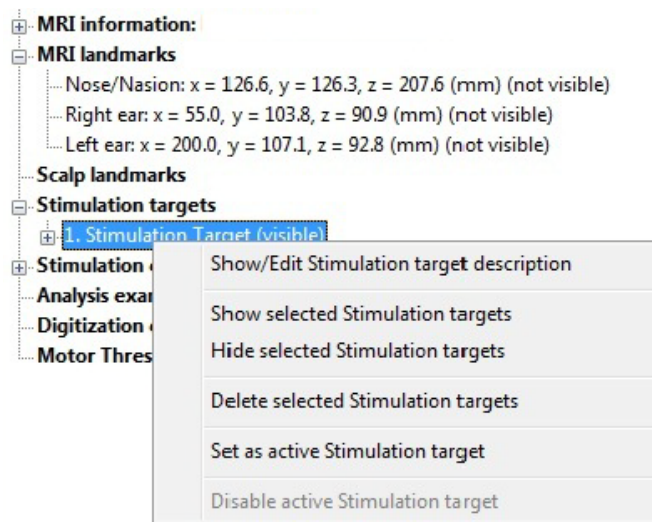


Fig. 32. NBS data session tree structure and an example of the pop-up menu

The session tree shows the stored NBS session research data:

- **General:** Session file name, creation time, researcher, organization, and session description
- **Patient/Subject information:** Patient/subject name in the NBS session, age, gender, handedness, and ID
- **MRI information:** Patient/subject name in MR images, date, number of slices, and MR image format
- **MRI landmarks:** Registration information of the nasion, left ear, and right ear coordinates
- **Scalp landmarks:** Registration information of the nasion, left ear, and right ear coordinates
- **Stimulation targets:** Visibility, location, and description of the target

- **Stimulation exams:** Creation time, researcher, description, description of the sequence, system information, as well as various information on the stimuli
- **Analysis exams:** Collection of stimuli from stimulation exams, including information on the creation time, researcher, and description of the analysis stimuli (for example, ID of the original stimuli, visibility of the analysis stimuli)
- **Digitization exams:** Creation time, researcher, description, and information on the digitization points
- **Motor Thresholds:** Creation time of the MT exam, researcher, description, muscle, coil and stimulator name, peeling depth, amplitude threshold, starting stimulus, and information on the MT sequence.

To access the context-specific pop-up menus, right-click the mouse over an item in the session tree. For more instructions, refer to Chapter 6.13 “Using the session tree” on page 125.

## 5.4 MR images (2D images)

The MR cross-sectional images are displayed as 2D images. The MR images are displayed in the following order:

- Left: sagittal, displayed as if you were looking at the subject’s left ear.
- Middle: coronal, displayed as if the subject was looking away from you.
- Right: axial, displayed as if you were looking on the crown of the subject’s head.

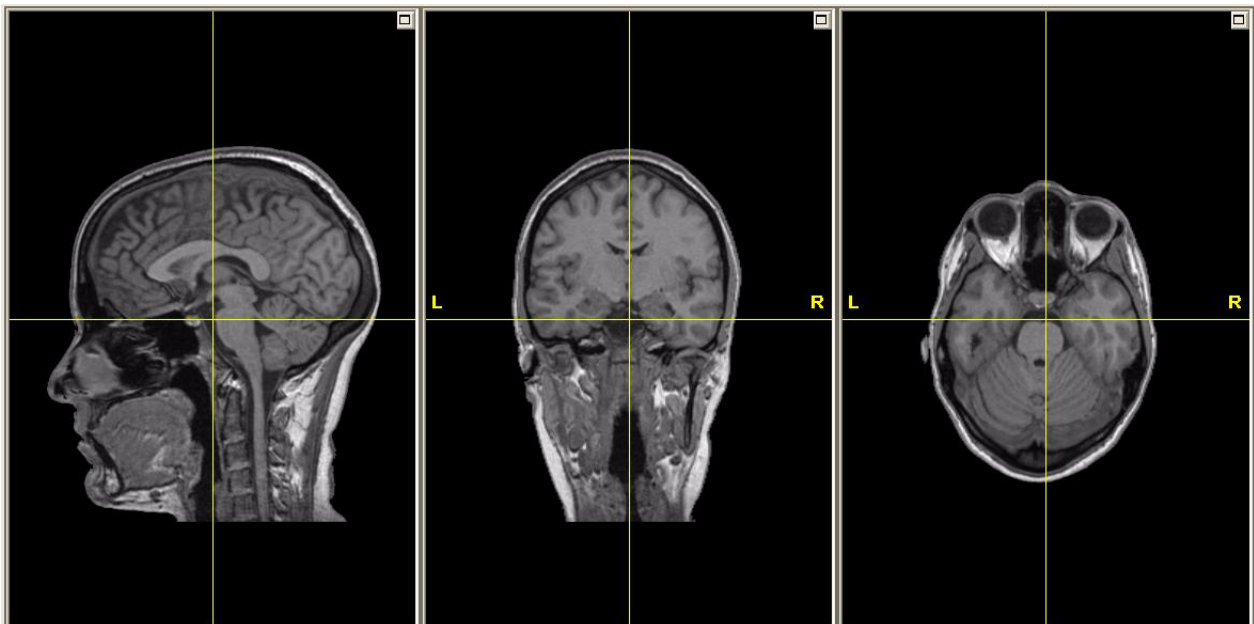


Fig. 33. MR images view



## 5.5 3D head

The Nexstim NBS software constructs the 3D head from the selected MRI stack. The 3D head function gives the possibility to view internal brain anatomy in three dimensions. The quality of the MR images is very important; the scalp surface of the generated 3D image should be clearly defined and match the head of the subject as closely as possible.

### 5.5.1 Peeling view

Peeling view displays the 3D head according to the peeling settings in the **Navigation**-tab (see Chapter 5.9 on page 55).

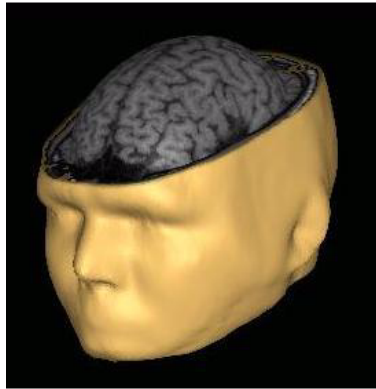


Fig. 34. 3D peeling view display

### 5.5.2 Cutting view

Cutting view displays the 3D head according to cutting lines settings in the **Navigation**-tab. In the cutting view you can cut away a piece of the 3D head. The segment is defined by the location of the crosshair cursor and the perspective of the 3D window. The cuts are made in the sagittal, axial and coronal direction.



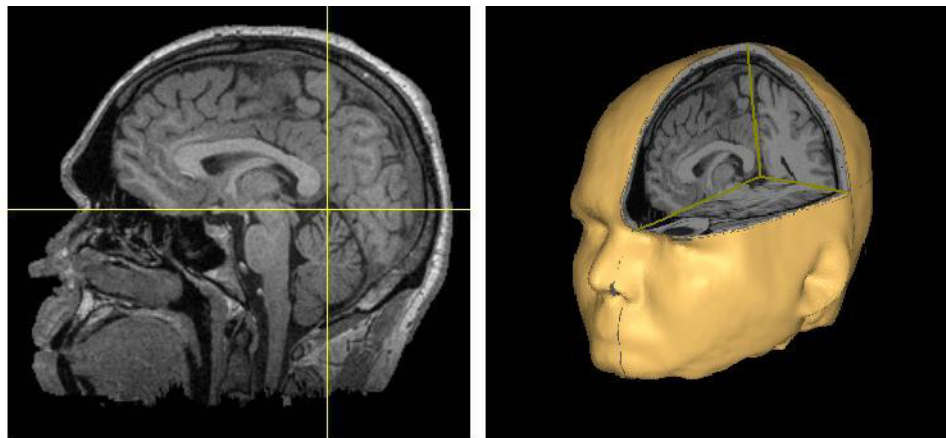
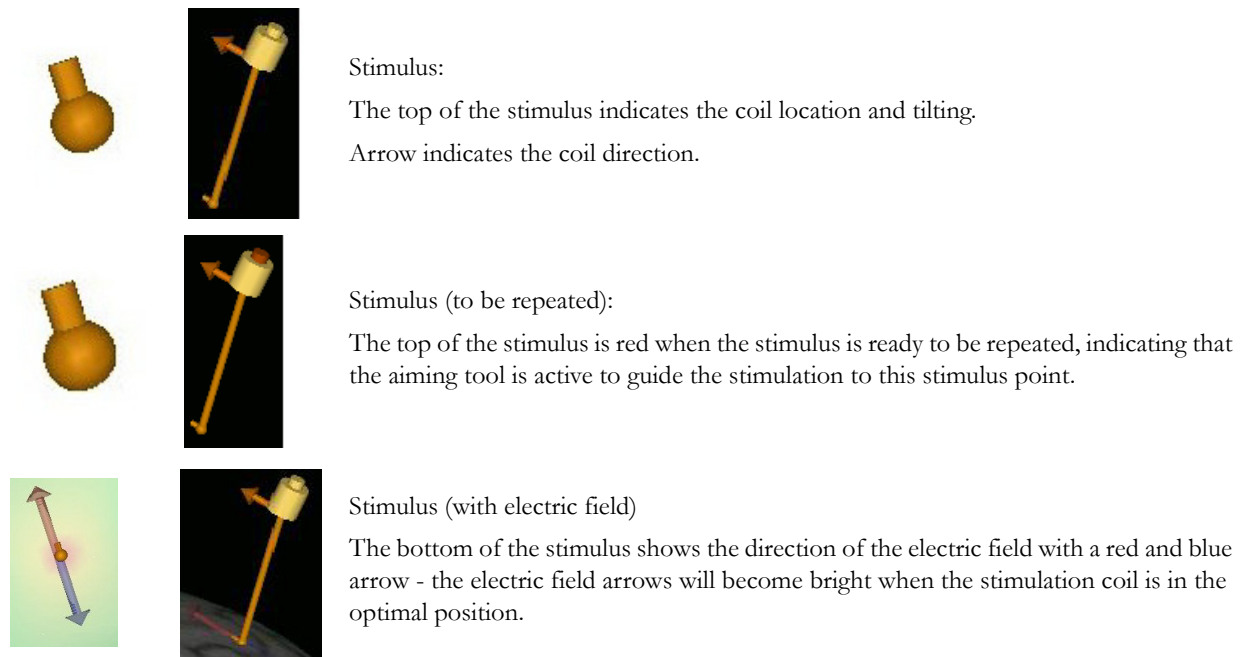


Fig. 35. 3D cutting view display

### 5.5.3 Visualized items on the 3D head

Digitization points, registration landmarks, the target grid, and stimulus points are displayed on the 3D view. In the following, the stimuli and targets are displayed both with and without scalp points. For more information, refer to Chapter 5.13 “Settings-tab” on page 76.

	Digitized point
	Advanced registration landmark
	Stimulation target (not active)
	Stimulation target (active): The top of the target is red when the target is active. Targeting grid becomes visible when stimulation target is active (and the <b>Show target grid</b> -option under <b>Settings</b> -tab is selected).



Note that a selected stimulus or digitization point will be brighter than an unselected point.

## 5.6 Electric field display

The real-time electric field of the stimulation coil is shown in Figure 36. The central red area of the electric field indicates which parts of the brain are stimulated the most, and reflects the accuracy of the NBS System. The yellow, green, and blue areas indicate which parts of the brain receive progressively less stimulation. Once a pulse is given, the calculated center of the red area is tagged with a stimulus. The calculated electric field generated by the pulse can also be displayed later.

For more information, see Chapter 5.13.1 “Setup-tab” on page 76.

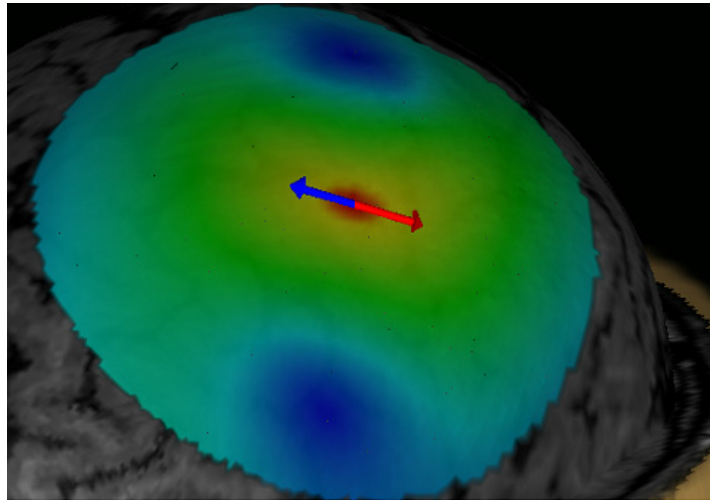


Fig. 36. E-field display

## 5.7 Aiming Tool

Aiming Tool is located on the lower right corner of the NBS display. It is activated when repeating stimuli. The Aiming Tool guides you to position the coil exactly to the correct position. The correct position of the coil is indicated with the Aiming Tool center (see Figure 37):

- Red: the coil is incorrectly positioned.
- Green: the coil is correctly positioned.

When **Location controlled stimulation** is selected in the currently open stimulation dialog, the targeted stimulus is only delivered when the coil is in the correct location.

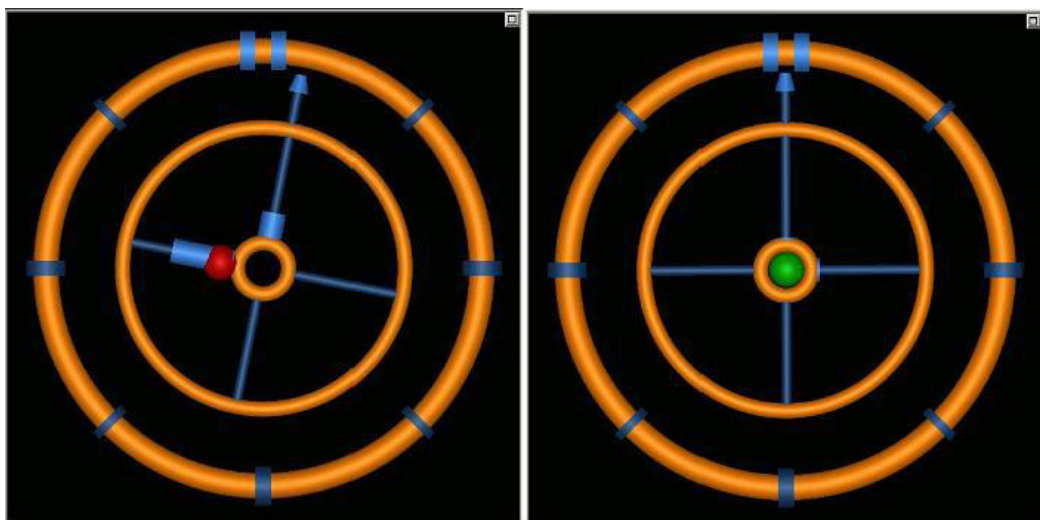


Fig. 37. Aiming Tool (off target on the left, on target on the right)

The correct positioning of the coil means taking into consideration:

- the coil tilting
- the coil location over the head
- the coil rotation angle.

The tilting, location, and rotation of the coil is indicated in the blue lines: the longer the thick blue line is, the further away the coil is from the target position. Locate the coil so that the blue arrow points directly up and the blue lines in the viewfinder are all thin.

## 5.8 Info panel

The bottom part of the Nexstim NBS display is called Info panel.



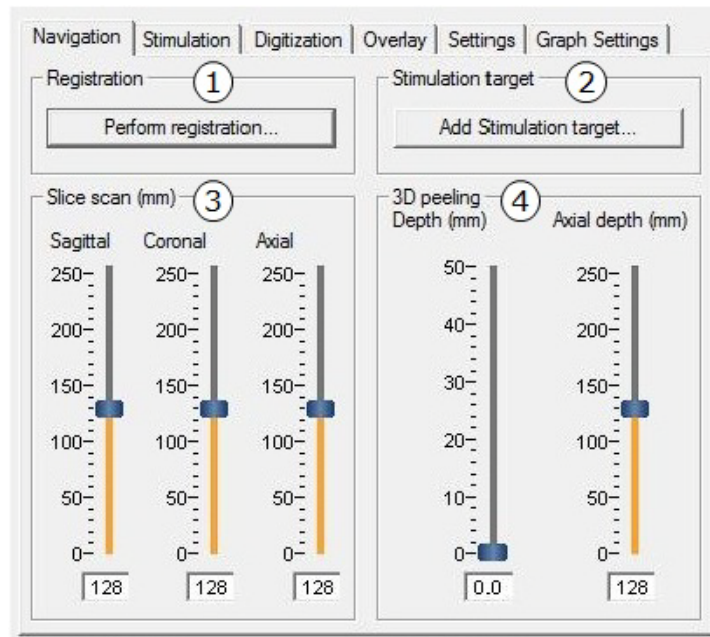
Fig. 38. Info panel

Table 8 Info panel indicators

1	Max (V/m)	The maximum value of the electric field on the peeled surface (hotspot). Electric field visualization shows the area where the maximum value is found. When a stimulus is delivered, a stimulus marker is set to the location where the maximum electric field value is found.
2	Target (V/m)	The value of the electric field at an active stimulation target location. Electric field value is calculated separately. Hence, the MRI target can be located outside of the peeled surface. The stimulation target values are displayed only if one stimulation target is set as active.
3	Distance (mm)	The distance of the hotspot to the stimulation target location
4	Crosshair (V/m)	The value of the electric field at crosshair. Electric field value is calculated separately for the crosshair. The crosshair values are visible only if the crosshair is set visible.
5	Dist (mm)	Shortest distance from the crosshair to the head surface
6	Aim (mm)	The distance to the accurate location of a repeated stimulus with the Aiming Tool. Distance to the repeated stimulus is visible only during location controlled stimulation.

## 5.9 Navigation-tab

**Navigation**-tab provides information on the navigation tools and controls the viewing of the MRI images and 3D head. Also, this tab is used to start the registration and to add the stimulation targets.



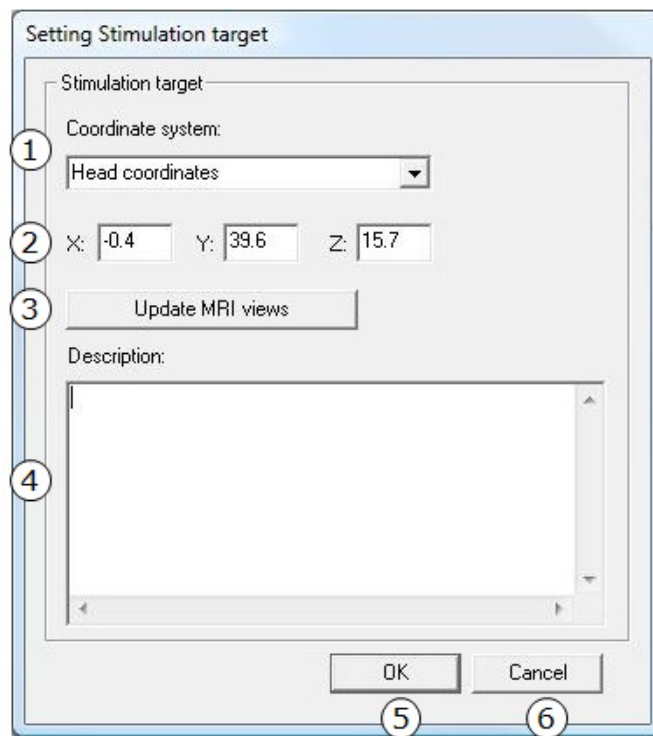
**Fig. 39.** Navigation controls

Table 9 Navigation control definitions

1	Registration	Clicking the <b>Perform registration...</b> -button opens the <b>Registration</b> -dialog for registering landmarks. (See Figure 70 on page 93.)
2	Stimulation target	Clicking the <b>Add Stimulation target...</b> opens the <b>Setting Stimulation target</b> -dialog for specifying a target location in the brain. (See Chapter 5.9.1 on page 56.)
3	Slice scan (mm)	Used for specifying the sagittal, coronal, and axial MR image slices displayed. Use either the sliding scales or type the exact slice numbers in the boxes below the sliders.
4	3D peeling	Used for specifying the way that the 3D head model is viewed. You can enter the depth manually or using the slider. <ul style="list-style-type: none"> <li>• <b>Depth (mm)</b> defines the brain surface peeling setup from the scalp surface. Note that the deeper the viewed brain structures are, the smoother they appear.</li> <li>• <b>Axial depth (mm)</b> defines the skull peeling setup in millimeters for depth from the top of the head down. In the 3D window (peeling view state) the peeling is updated immediately according to the axial depth.</li> </ul>

### 5.9.1 Setting Stimulation target- dialog

Click the **Add Stimulation target** -button on **Navigation**-tab to open the **Setting Stimulation target** -dialog.



**Fig. 40.** Setting Stimulation target -dialog

Table 10 Setting Stimulation target controls

1	Coordinate system	Set the coordinate system used in the stimulation target setting. The options are MRI-coordinates, Head coordinates, and MR Scanner coordinates. See Chapter “Coordinate systems” on page 77.
2	Coordinates	Add the coordinate values for the target.
3	<b>Update MRI views</b>	Select to move the crosshair to the given coordinates on the NBS display and verify that the target location is correct.
4	Description	Enter a description for the stimulation target.
5	<b>OK</b>	Select to save the stimulation target and close the dialog.
6	<b>Cancel</b>	Click to close the dialog without saving any data.

## 5.10 Stimulation-tab

The **Stimulation**-tab is used for controlling the EMG device, as well as stimulation. The **Stimulation**-tab contains three sub-tabs (**EMG**, **Single Pulse**, and **Repetitive**), all described in the following chapters.

---

**NOTE:**

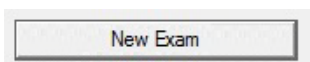
Repetitive stimulation is for use with NexSpeech only.

---

### New exam -button

The **New exam** -button in the **Stimulation**-tab is used to create a new stimulation exam.

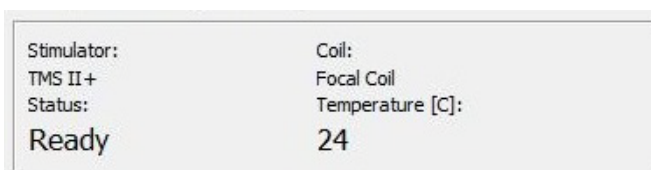
After a new exam has been started, the button changes to **Close exam**, which closes and deactivates the active stimulation exam from the session tree.



**Fig. 41.** New Exam -button

### System information

**Single pulse** and **Repetitive**-tabs, as well as **Defined series** and **rTMS**-dialogs contain the System status -field, which shows information on the TMS II Stimulator, as well as the coil type connected to the stimulator and its temperature in degrees Celsius.



**Fig. 42.** System information

The stimulator is TMS II , and its status is one of the following:

- **Ready:** TMS II is ready for the following operation. Stimulation (among others) can begin.
- **Disconnected:** TMS II is shut down or USB cable is disconnected.
- **Charged:** TMS II is charged and ready for the following operation. For example, stimulation can begin. Do not unplug the coil when the TMS status is “Charged”.



- **Charged (On Hold):** Stimulation cannot continue (e.g. tracking unit loses visibility of the coil).
- **Stimulating:** TMS II carries out the stimulation sequence.
- **Paused:** Stimulation has been paused by the user. The coil can be changed or stimulation can be started.
- **No Coil:** No coil is connected to the TMS II Stimulator.
- **Stimulator Hot:** TMS II temperature is too high for stimulation. Stimulation is blocked.
- **Error:** TMS II notices a fault and has to be restarted.
- **Coil Hot:** This is displayed in red. Coil temperature is too high for stimulation.
- **Coil Not Ready:** Initialization of the coil is not yet ready.
- **Coil Old:** The stimulation coil has reached its mechanical lifetime. The coil must be replaced.

### 5.10.1 EMG-tab

The EMG-controls can be navigated to by clicking the **Stimulation > EMG**-tab on the main NBS view.

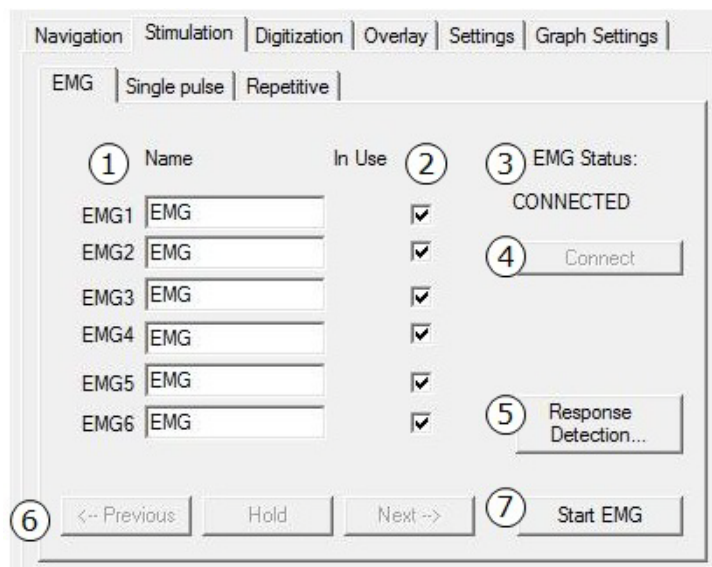


Fig. 43. EMG controls

Table 11 EMG control definitions

1	Name	Each EMG channel from 1-6 can be assigned a specific name (for example, which muscle the EMG channel is connected to). The channel name will also be visible in the EMG display.
2	In Use	Check the EMG channels to be measured.



Table 11 EMG control definitions

3	EMG Status	Shows the status of the EMG device: <ul style="list-style-type: none"> <li>• <b>NOT CONNECTED:</b> The EMG device USB cable is not connected to the NBS computer or there is no power connected to the EMG device. There is no connection between the NBS and the EMG device.</li> <li>• <b>CONNECTED:</b> The EMG device is correctly connected to the NBS computer. The EMG device ready to perform measurements.</li> <li>• <b>MEASURING:</b> EMG is measuring, but no sequence has been started.</li> <li>• <b>RECORDING:</b> EMG is measuring and a sequence has been started.</li> </ul>
4	<b>Connect</b>	Click to establish a connection between the NBS System and the EMG device. When the EMG is connected, the button is disabled.
5	<b>Response detection...</b>	Opens the <b>Response Detection</b> -dialog. The button is disabled during single pulse stimulation or MT determination.
6	Stimulus navigation buttons	The <-- <b>Previous</b> and <b>Next</b> --> buttons are active during a stimulation session, allowing to browse for stimuli forwards and backwards in the continuous EMG display. Click <b>Hold</b> to freeze the continuous view of the EMG display (the button label changes to <b>Release</b> ).
7	<b>Start EMG / Stop EMG</b>	Click here to turn on the EMG measurement. The EMG display will show responses of each channel in use. After starting EMG measurement, this button changes to <b>Stop EMG</b> . Clicking the button will stop the EMG measurement.

### Response Detection -dialog

In the **Stimulation > EMG**-tab, click **Response detection...** to open the **Response Detection** -dialog.

**NOTE:**

The set response detection settings are not visible during stimulation.

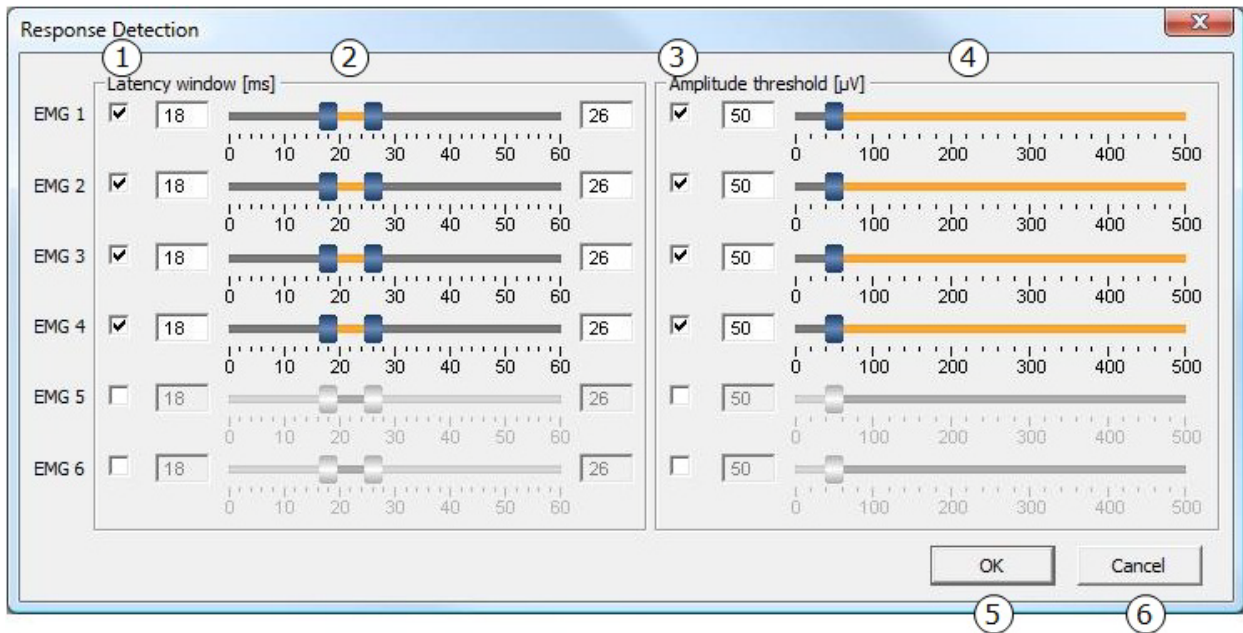


Fig. 44. Response Detection -dialog

Table 12 Response Detection -dialog definitions

1	Check box for EMG channel Latency Window	Select to activate the latency filter for the corresponding EMG channel.
2	Double slider	<p><b>NOTE:</b> Left and right markers cannot be moved past one another.                  Slider ranges from Latency Window minimum to maximum value (0 ms - 60 ms), with tick mark every 10 ms.                  Moving the slider updates the corresponding edit field value.                  You can move the left marker by:</p> <ul style="list-style-type: none"> <li>• clicking and dragging using the left mouse button</li> <li>• clicking the slider using the left mouse button</li> <li>• clicking the marker with the left mouse button and using either mouse wheel or arrow keys.</li> <li>• entering the value in the edit field on the left side</li> </ul> <p>You can move the right marker by:</p> <ul style="list-style-type: none"> <li>• pressing the CTRL-button and clicking and dragging the left mouse button</li> <li>• clicking the slider using the right mouse button</li> <li>• pressing the CTRL-button and clicking the marker with the left mouse button and using either mouse wheel or arrow keys.</li> <li>• entering the value in the edit field on the right side</li> </ul>
3	Check box for EMG channel Amplitude Threshold	Select to activate the amplitude threshold filter for the corresponding EMG channel.

Table 12 Response Detection -dialog definitions

4	Amplitude Threshold slider	<p>Ranges from Amplitude Threshold minimum to maximum values (0 <math>\mu</math>V - 500 <math>\mu</math>V). Range scale has tick mark every 100 <math>\mu</math>V.</p> <p>Moving the slider marker updates the corresponding edit field value.</p> <p>You can move the marker by:</p> <ul style="list-style-type: none"> <li>• clicking and dragging using the left mouse button,</li> <li>• clicking the slider using the left mouse button, or</li> <li>• clicking the marker with the left mouse button and using either mouse wheel or arrow keys</li> <li>• entering the value in the edit field on the left side</li> </ul>
5	<b>OK</b>	Click to save the changes and close the dialog.
6	<b>Cancel</b>	Click to close the dialog without saving the changes.

### 5.10.2 Single pulse -tab

The **Single pulse** -tab allows you to:

- Identify the system status
- Select single-pulse or Defined series stimulation, and
- Open the stimulation dialog for the selected stimulation mode.

Also refer to chapters 6.11.2 “Single-pulse stimulation” on page 111 and 6.11.3 “Defined series stimulation” on page 112.

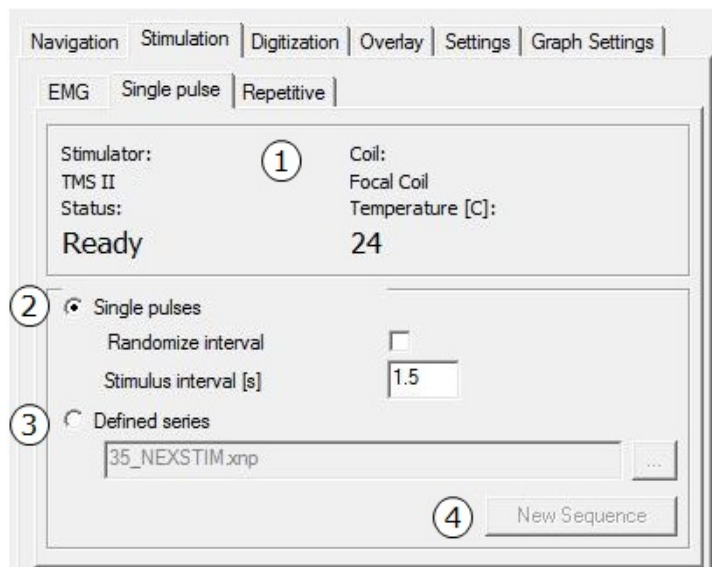
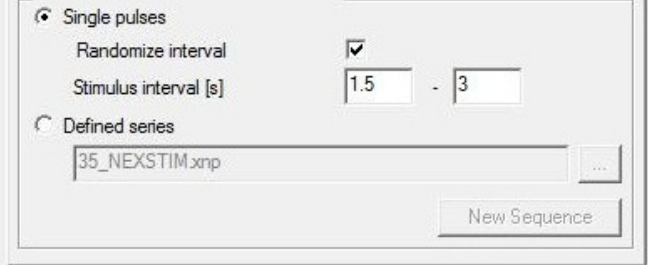
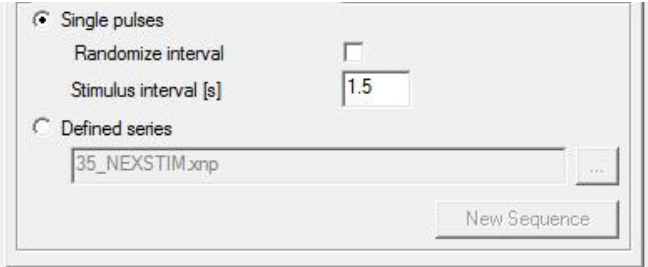


Fig. 45. Single pulse -tab

Table 13 Single-pulse stimulation control definitions

1	Stimulator and coil information	See Chapter “System information” on page 57.
2	Single pulses: Randomize interval	<p>Select to stimulate in randomized interval.</p> <p>To display the field, you must have “Show ISI and randomize” selected in the <b>Settings &gt; Setup</b>-tab (see Chapter 5.13.1 on page 76).</p> <p>Selecting this check box also displays the second stimulus interval field. Using these fields you can set the minimum and maximum values for the stimulus interval range, within which the stimulus interval will alternate.</p>  <p><b>Fig. 46.</b> Randomized stimulus interval</p>
2	Single pulses. Stimulus interval [s]	<p>Enter here the desired stimulus interval. The minimum stimulus interval is 1 s (1.5 s with EMG in use) and the maximum interval is 10 s. Holding down <b>S</b> or the left pedal delivers stimuli with the selected stimulus interval.</p> <p>To display the field, you must have “Show ISI and randomize” selected in the <b>Settings &gt; Setup</b>-tab (see Chapter 5.13.1 on page 76).</p>  <p><b>Fig. 47.</b> Constant stimulus interval</p>
3	Defined series	<p>Defined series are predefined stimulation programs, that is, series of single pulses. The interstimulus interval (ISI) and stimulus intensities may vary from stimulus to stimulus.</p> <p>Selecting this radio button and clicking the [...] -button opens the <b>Select Defined Series</b> -dialog (see Fig. 49. on page 64), where you can select the specific series.</p>
4	<b>New sequence</b>	<p>Depending whether you have decided to use the Single pulses or Defined series -mode, clicking this button opens either the <b>Stimulation in single pulse mode</b> -dialog (described in the following chapter), or the <b>Defined Series Run</b> -dialog (see Figure 50 on page 65).</p> <p>For more information on Defined series, see Chapter 6.11.3 “Defined series stimulation” on page 112.</p>

Stimulation in single pulse mode -dialog

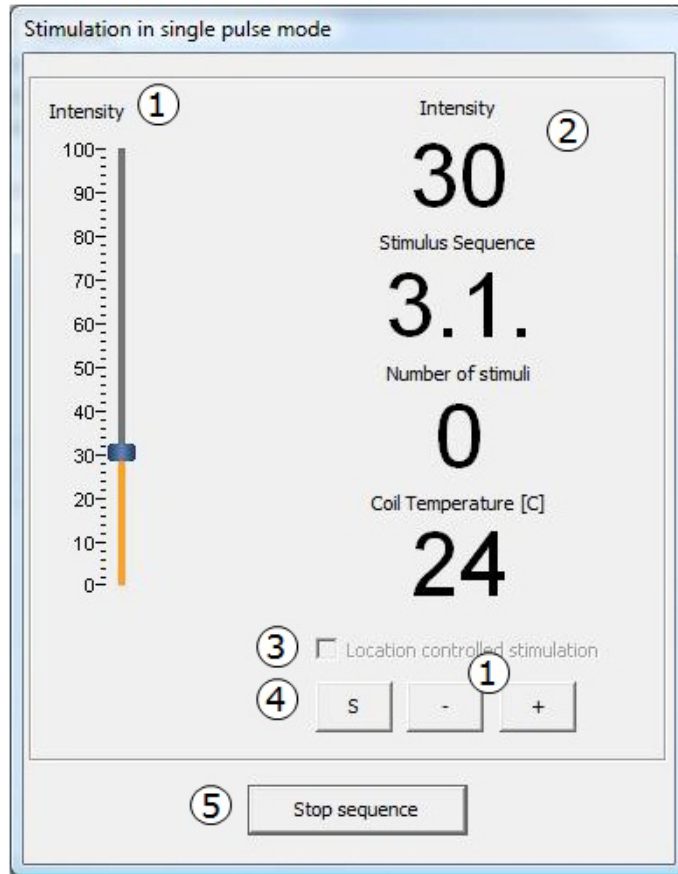


Fig. 48. Stimulation in single pulse mode -dialog

Table 14 Single-pulse stimulation controls

1	Intensity adjustment controls	<p>The Intensity slider, dialog buttons - and +, and the middle and right pedals in the foot switch can be used to adjust the stimulation intensity during stimulus sequence. The middle pedal or - -button decreases the intensity and right pedal or + -button increases the intensity. When the foot switch is held down the intensity value changes at an increasing speed.</p> <p>The slider can be engaged by pressing the left-mouse button and moving the indicator to the desired intensity value. You can also set the intensity by clicking the slider to the desired position.</p>
2	Stimulation information	<p>The numbers provide information about the stimulation intensity, stimulus sequence ID, number of stimuli given and the current coil temperature (in degrees Celsius).</p> <p>If the coil becomes too hot, the temperature will be displayed in red and stimuli cannot be given.</p>
3	Location controlled stimulation	<p>Select this if you want to repeat the conditions of a Repeated stimulus. See Chapter 6.11.10 “Location controlled stimulation” on page 118.</p> <p>This is disabled if registration has not been performed.</p>

Table 14 Single-pulse stimulation controls

4	<b>S</b>	<p>Stimuli are delivered by clicking <b>S</b> or the left foot pedal.</p> <ul style="list-style-type: none"> <li>• A single stimulus is delivered by pressing <b>S</b> or left pedal once.</li> <li>• If “Show ISI and randomize” is selected in the <b>Settings &gt; Setup</b>-tab, holding down <b>S</b> or the left pedal delivers stimuli with predefined stimulus interval.</li> </ul>
5	<b>Stop sequence</b>	Click to close the current stimulation sequence. Closing the sequence will open the sequence description window and close this dialog.

### Select Defined Series -dialog

Selecting the **Defined series** -radio button and click the [...] -button in the **Single pulse** -tab opens the **Select Defined Series** -dialog.

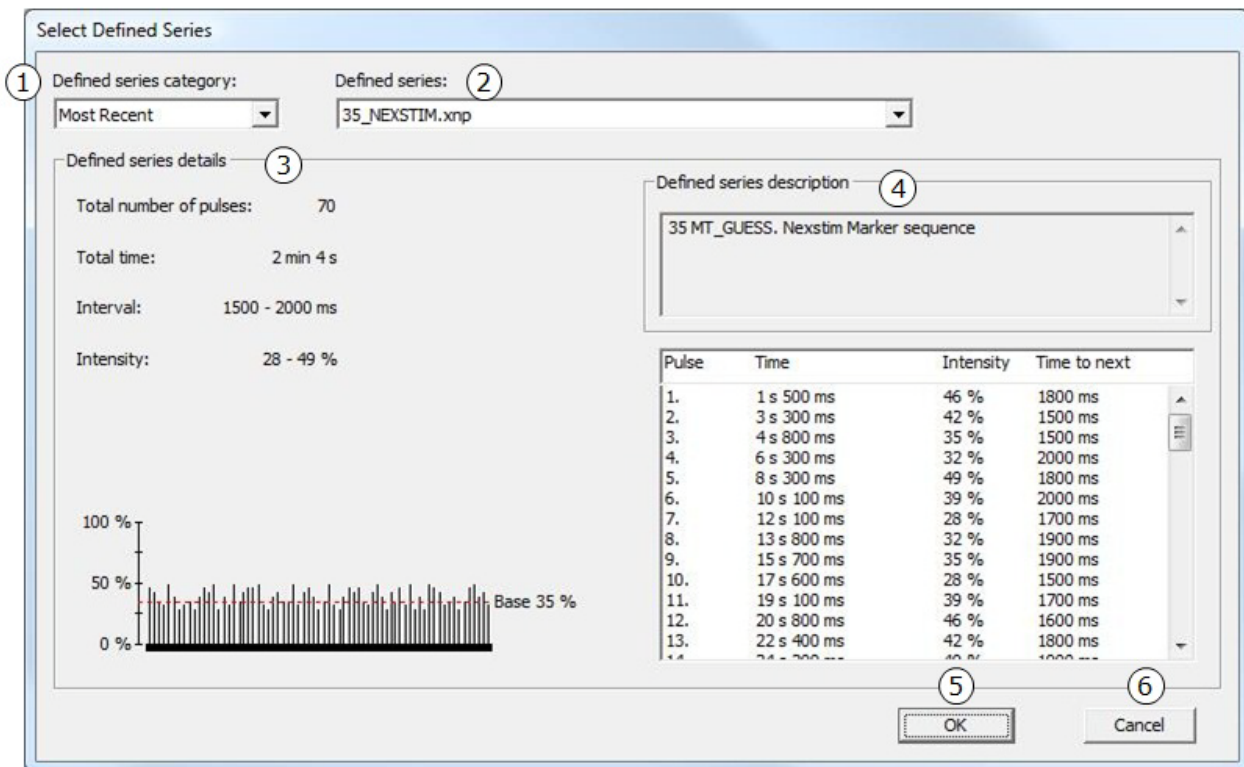


Fig. 49. Select Defined Series -dialog

Table 15 Select Defined Series -dialog controls

1	Defined series category	<p>Select the Defined series category from the pull-down menu.</p> <ul style="list-style-type: none"> <li>• <b>Most recent:</b> The last Defined series that was selected.</li> <li>• <b>Nexstim:</b> Lists the pre-programmed file names of the Nexstim-generated series alphanumerically.</li> </ul>
2	Defined series	Select the Defined series -file from the pull-down menu.

Table 15 Select Defined Series -dialog controls

3	Defined series details	<p>Displays information on the Total number of pulses, Total stimulation time, Interval, and Intensity of the selected Defined series.</p> <p>Also a diagram of the selected defined series is shown, where base intensity is marked with a red dashed line. (For more information on base intensity, see item 3 Table 16.) This information is shown more detailed in a table, where one row describes one stimulus.</p> <p>You may select one or more rows from the list.</p> <ul style="list-style-type: none"> <li>To select successive multiple rows, hold the SHIFT key and select the first and last rows. All the rows inbetween will also be selected.</li> <li>To select separate single rows, hold the CTRL key and select the rows by clicking on them.</li> </ul> <p>The selected pulses are highlighted in the preview.</p>
4	Defined series description	Displays description of the Defined series.
5	<b>OK</b>	Closes the dialog and confirms the selection.
6	<b>Cancel</b>	Closes the dialog without saving the changes.

### Defined Series Run -dialog

When the Defined series -mode is selected in the **Single pulse** -tab, clicking the **New Sequence** -button opens **Defined Series Run** -dialog.



Fig. 50. Defined Series Run -dialog



Table 16 Run Defined series -dialog controls

1	Defined series status	Displays the Defined series file name, Total number of pulses in the selected Defined series sequence, the number of pulses remaining in the sequence, Total stimulation time, and the remaining stimulation time.  Also a diagram of the selected defined series is shown, where base intensity is marked with a red dashed line. During stimulation, the elapsed part of the sequence is colored green.
2	System status	See Chapter “System information” on page 57.
3	Intensity	<ul style="list-style-type: none"> <li>• <b>Next pulse:</b> Displays the intensity of the next pulse to be delivered.</li> <li>• <b>Base:</b> Move the slider to adjust the base intensity line in the preview diagram. The slider ranges from 0 to 100. Adjusting the slider is not allowed during sequence.</li> </ul> <p>In Defined series, there is a base intensity and all intensities are given as relative intensities. Base intensity is a part of absolute intensity. For example, if base intensity is 30% and the relative intensity is -5%, then absolute intensity will be <math>30\% - 5\% = 25\%</math>. Absolute intensity is the one delivered by the stimulator.</p>
4	Sequence description	When the stimulation is stopped (that is, stimulator has reached the end of the Defined series sequence or you have clicked the <b>Stop</b> -button), you can enter here the description for the completed sequence. Press <b>Enter</b> to add a row.
5	<b>Start</b>	Click to start the stimulation. A new Defined series sequence is created in the session tree. You may also push the left foot switch once to start stimulation.
6	<b>Pause</b>	Click to pause the stimulation. Stimulation is also paused when the stimulator is held from stimulation (e.g. Aiming Tool).  You may also push the left foot switch once to pause stimulation.
7	<b>Stop</b>	Click to stop the stimulation.
8	Intensity Control (foot pedal)	Select to allow intensity adjustment using the foot switch. Selecting this box allows intensity adjustment using the foot switch: <ul style="list-style-type: none"> <li>• Middle pedal: Decrease the intensity</li> <li>• Right pedal: Increase the intensity.</li> </ul> Active when Base Intensity slider is enabled.
9	Location controlled stimulation	When checked, the stimulation is controlled via Aiming Tool. When unchecked, Aiming Tool is in use, but does not control the stimulation.
10	<b>Close</b>	Closes the dialog.



### Defined series Description -dialog

In the **Defined series Description** -dialog you are able to edit the Defined series description after it has been saved in the session tree.

Open the dialog from the session tree by selecting **Show/Edit Sequence Description** on a **Defined series Sequence** pop-up menu. The dialog shows a snapshot of the Defined series stimulation when the stimulation was stopped.

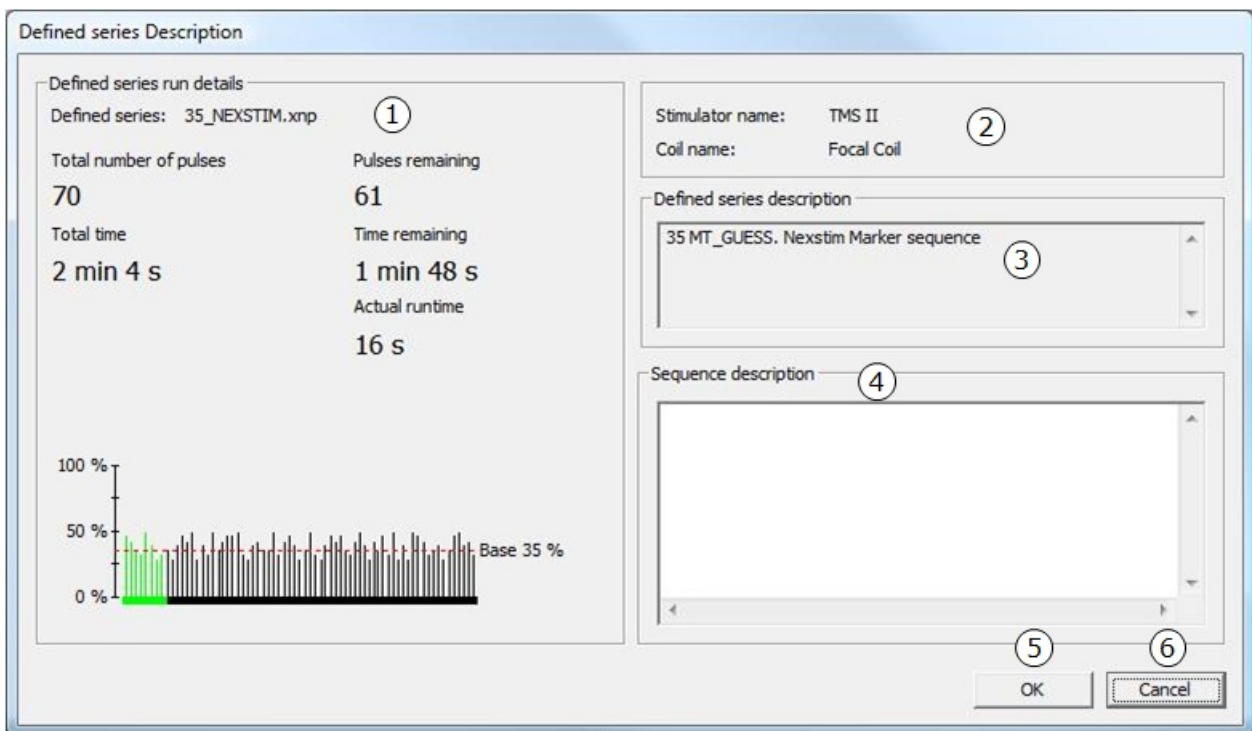


Fig. 51. Defined series Description -dialog

Table 17 Defined series Sequence Description -dialog description

1	Defined series run details	Displays the Defined series file name, Total number of pulses, Pulses remaining, Total time, Time remaining, and the Actual runtime of the Defined series sequence. Also a diagram of the Defined series is shown, where the base intensity is marked with a red dashed line. The elapsed time is colored green.
2	System information	The names of the stimulator and coil used in the Defined series sequence are displayed.
3	Defined series description	Displays description of the Defined series.
4	Sequence description	Shows the description entered after stopping the sequence. When editing, press <b>Enter</b> to add a row.
5	<b>OK</b>	Closes the dialog and saves the changes.
6	<b>Cancel</b>	Closes the dialog without saving the changes.

### 5.10.3 Repetitive-tab

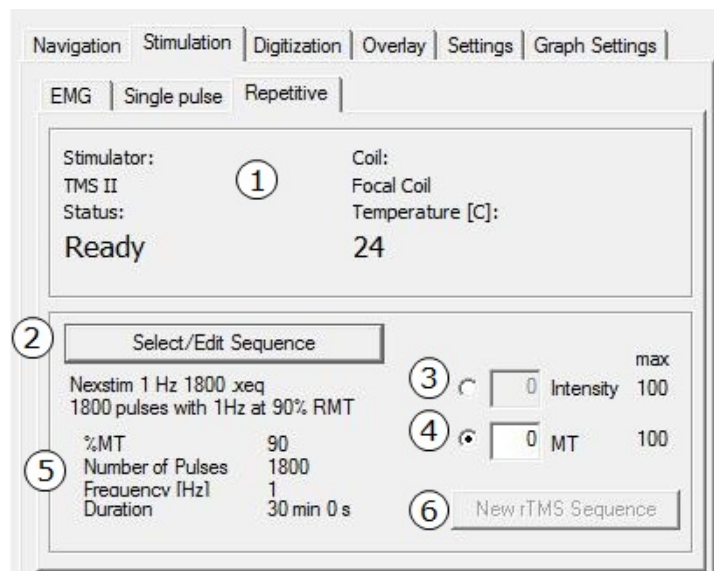
**NOTE:**

Repetitive stimulation is for use with NexSpeech only.

The **Repetitive**-tab allows you to:

- Identify the system status
- Open a dialog for selecting, editing, and/or saving an rTMS sequence
- Set the stimulation intensity (either directly or with reference to MT)
- Open the stimulation dialog.

Refer also to Chapter 6.11.4 “Repetitive stimulation” on page 113.



**Fig. 52.** Repetitive-tab

Table 18 Repetitive stimulation control definitions

1	Stimulator and information	See Chapter “System information” on page 57.
2	<b>Select/Edit Sequence</b>	<p>Opens the <b>rTMS Sequence Editor</b> -dialog, where you can load, edit and save repetitive sequences. (See “rTMS Sequence Editor -dialog” on page 69.)</p> <p>The file name and description of the last selected repetitive stimulation sequence are displayed under the button.</p> <p>You can edit sequences without opening a session.</p>

Table 18 Repetitive stimulation control definitions

3	Intensity	<p>Select the radio button to activate the Intensity field.</p> <p>You can enter intensity values from 0 to 100% (with increments of 1).</p> <p>The intensity is also limited according to the number of pulses per minute defined in the sequence. As the number of pulses increases, the maximum intensity decreases.</p> <p>Selecting the MT radio button disables the Intensity field and shows the stimulator intensity values that are calculated from the set MT and %MT values [<math>\%MT \times MT = Intensity</math>].</p> <p>The maximum allowed intensity value is also displayed.</p> <p>For more information, refer to Appendix A.3 “Nexstim TMS II Stimulator” on page 192.</p> <p><b>NOTE:</b> Disabled when the stimulator is disconnected.</p>
4	MT	<p>Select the radio button to activate the MT field.</p> <p>You can enter MT values from 0 to 100% (with increments of 1).</p> <p>Entering a new MT value updates the Intensity value based on MT and %MT setting [<math>\%MT \times MT = Intensity</math>].</p> <p>Selecting the Intensity radio button disables the MT field, and %MT is grayed out.</p> <p>The MT radio button and MT edit control are enabled only if %MT is set in the sequence.</p> <p>The maximum allowed MT value is also displayed.</p> <p><b>NOTE:</b> Disabled when the stimulator is disconnected.</p>
5	Sequence information	<p>The %MT, number of pulses in the rTMS sequence, frequency of stimuli in bursts in the rTMS sequence, and duration of the rTMS sequence are displayed.</p>
6	<b>New rTMS Sequence</b>	<p>Opens the <b>rTMS Run</b> -dialog (see “rTMS Run -dialog” on page 72).</p>

### rTMS Sequence Editor -dialog

Click the **Select/Edit Sequence** -button to open the **rTMS Sequence Editor** -dialog.

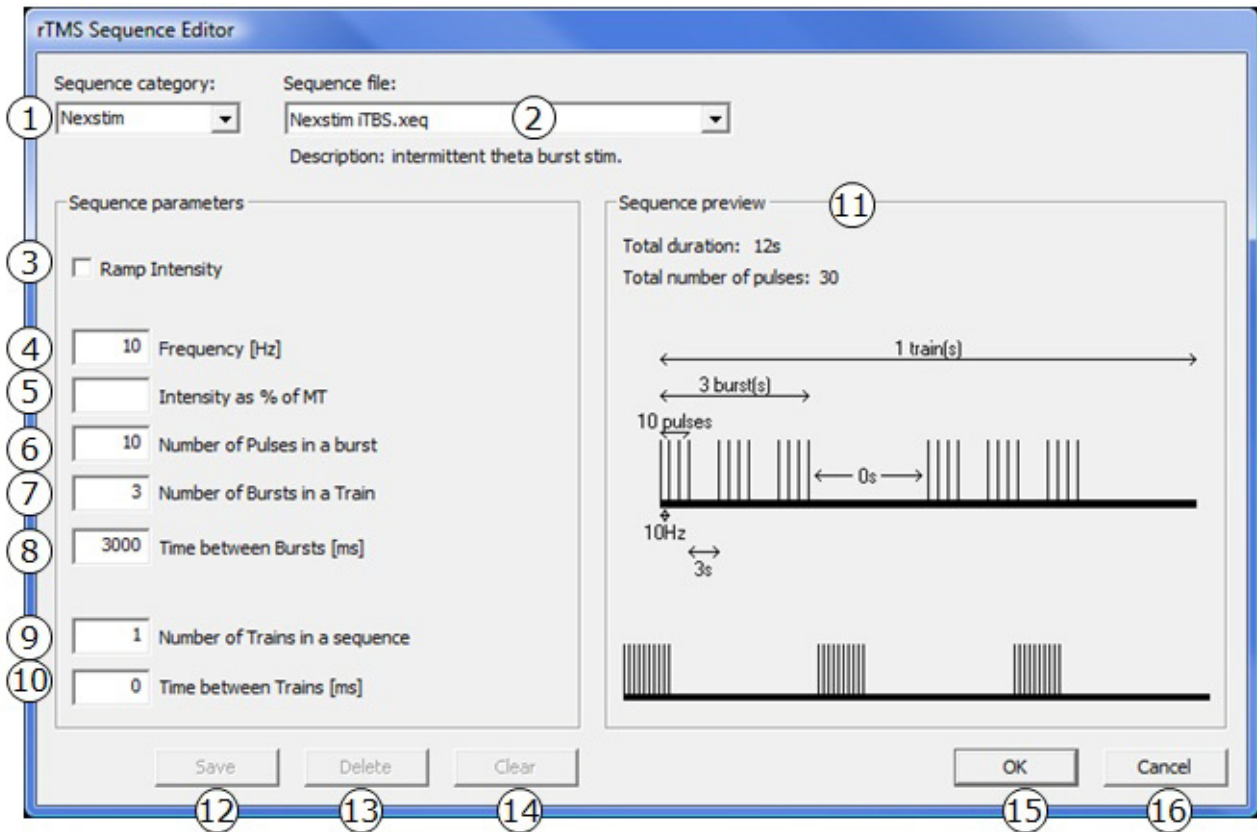


Fig. 53. rTMS Sequence Editor

Table 19 rTMS Sequence Editor controls

1	Sequence category	<p>Select the rTMS sequence category from the pull-down menu.</p> <ul style="list-style-type: none"> <li>• <b>Most recent:</b> Shows the last selected sequence. This category is automatically selected after clicking the <b>Select/Edit Sequence</b> -button in the <b>Repetitive</b>-tab.</li> <li>• <b>Nexstim:</b> Lists the pre-programmed file names of the Nexstim-generated sequences alphanumerically. You are allowed to edit the parameter values for Nexstim-generated sequences, but when you save the sequence, it is saved under the User category.</li> <li>• <b>User:</b> Lists the rTMS sequence files defined by the user in alphanumerical order.</li> </ul> <p>You are also able to select and edit a any sequence without opening a session.</p>
2	Sequence file	<p>Select the rTMS sequence file from the pull-down menu. The description of the selected sequence is displayed under the menu.</p>
3	Ramp Intensity	<p>Select the Ramp Intensity check box to gradually increase the stimulation intensity.</p>
4	Frequency [Hz]	<p>Displays the frequency value from the selected sequence. You can enter positive values between 0.1 - 10 Hz in increments of 0.1 Hz.</p>

Table 19 rTMS Sequence Editor controls

5	Intensity as % of MT	You can enter whole, positive values from 1 to 150 %. The field can also be left empty.
6	Number of Pulses in a burst	Set the number of pulses in a burst.
7	Number of Bursts in a train	Set the number of bursts in a train.
8	Time between Bursts [ms]	Set the time between bursts. The time between bursts must be the same or longer than the time between pulses. If this is not entered correctly, an error message is displayed when <b>OK</b> or <b>Save</b> is clicked.
9	Number of Trains in a sequence	Set the number of trains in a sequence of the selected sequence.
10	Time between Trains [ms]	Set the time between trains of the selected sequence. The time between trains must be the same or longer than the time between bursts. If this is not entered correctly, an error message appears.
11	Sequence preview	<ul style="list-style-type: none"> <li>• <b>Total duration:</b> Displays the total time of the sequence. The duration is updated real-time based on the values entered in the Sequence parameters fields. If the combination of the values entered exceeds the maximum safe guideline (120 min), a warning dialog is displayed.</li> <li>• <b>Total number of pulses:</b> Shows the total number of pulses.</li> <li>• <b>Sequence preview:</b> The sequence previews are built real-time as you select the number of pulses, bursts and trains. The preview data are blank until appropriate values are entered (e.g., Time between bursts, Number of Trains in a sequence and Time between trains).</li> </ul>
12	<b>Save</b>	<p>Clicking this opens the <b>Save sequence</b> -dialog, where you can save the sequence and associated values with a specific filename and a description.</p> <ul style="list-style-type: none"> <li>• Clicking <b>OK</b> saves the sequence file with <i>.seq</i> postfix under <i>RTMSSequenceFiles</i> directory.</li> <li>• Clicking <b>Cancel</b> closes the dialog, and the rTMS Sequence editor state remains unchanged.</li> </ul> <p>Sequences can only be saved to the “User” category.</p>
13	<b>Delete</b>	<p>When you select a sequence and click <b>Delete</b>, the sequence is deleted from the “User” category and no longer appears in the list.</p> <p><b>Delete</b> is disabled if the category selection is “Most Recent” or “Nexstim”.</p>
14	<b>Clear</b>	Click to clear the recent edits and return to the original values of the selected sequence.
15	<b>OK</b>	When you select a sequence and click <b>OK</b> , the dialog is closed and any changes are brought forward to the <b>Repetitive</b> -stimulation tab.
16	<b>Cancel</b>	Closes the dialog without saving any changes. Returns to the <b>Repetitive</b> -tab.

### rTMS Run -dialog

Click **New rTMS Sequence** in the **Repetitive**-tab to open the **rTMS Run** -dialog.

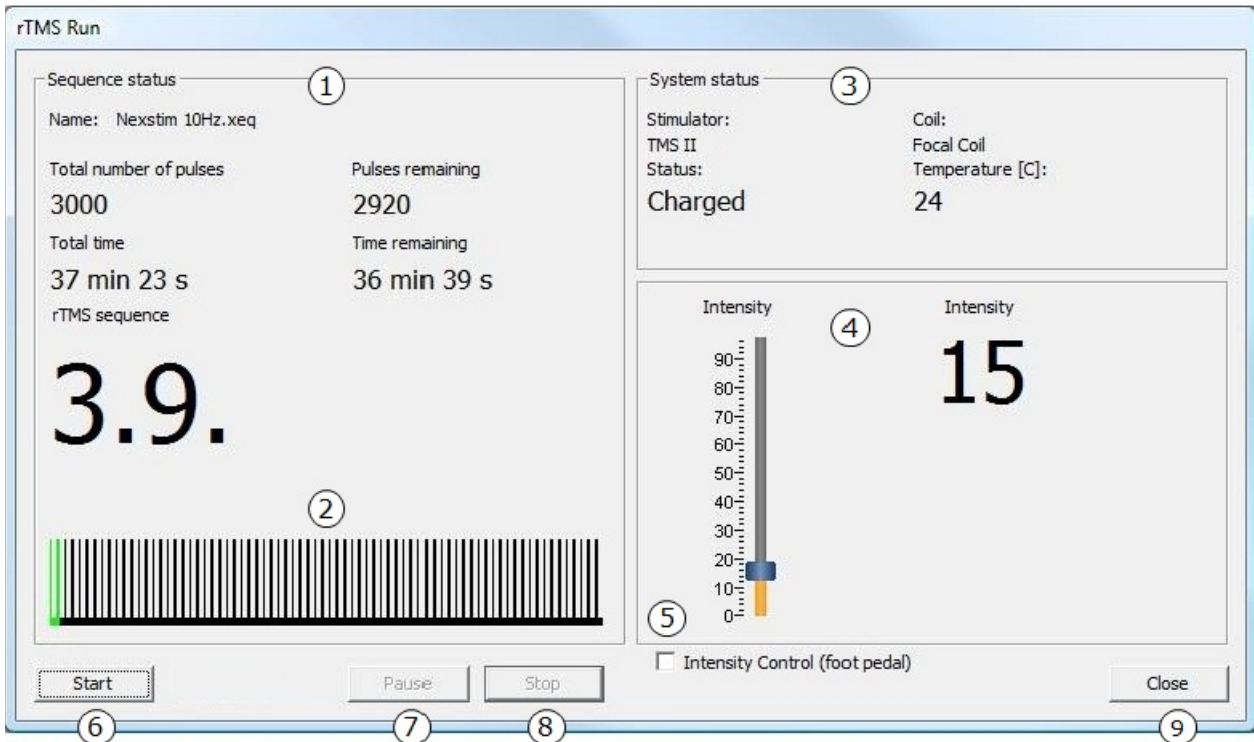


Fig. 54. rTMS Run -dialog

Table 20 rTMS Run controls

1	Sequence status	<p>Displays information on the rTMS sequence in progress:</p> <ul style="list-style-type: none"> <li>• <b>Name:</b> File name of the selected sequence.</li> <li>• <b>Total number of pulses:</b> Number of planned pulses in the sequence</li> <li>• <b>Pulses remaining:</b> Number of pulses remaining in the sequence</li> <li>• <b>Total time:</b> Total time of the sequence (planned)</li> <li>• <b>Time remaining:</b> Remaining duration of the sequence</li> <li>• <b>rTMS sequence:</b> Active rTMS sequence ID.</li> </ul>
2	Preview diagram	Displays the real-time proceeding of the sequence. Elapsed part of the sequence is colored green.
3	System status	See Chapter “System information” on page 57.
4	Intensity	Adjust the intensity using the slider (not when sequence is started or paused). The intensity is also shown in numbers.
5	Intensity Control (foot pedal)	Selecting this box allows intensity adjustment using the foot switch. When checked, the right pedal shall increase and the middle pedal shall decrease the intensity (and move the slider marker accordingly).

Table 20 rTMS Run controls

6	<b>Start</b>	Click to start or continue the sequence. Starting from a pause continues the sequence from where it was interrupted. Starting from a stop creates a new sequence. The sequence will start from the beginning and will be documented as a new sequence in the session tree. You can also use the left pedal on the foot switch to start the sequence.
7	<b>Pause</b>	Click to pause the stimulation. You can also use the left pedal on the foot switch to pause the sequence.
8	<b>Stop</b>	Click to terminate the sequence. The sequence data is written as is to the session and the sequence list and session tree are updated.
9	<b>Close</b>	Dismisses the <b>rTMS Run</b> -dialog. The <b>Close</b> -button is disabled while stimulation is in progress.

## 5.11 Digitization-tab

The **Digitization**-tab is used for documenting and controlling the digitization sessions (see Chapter 6.8.5 “Creating reference points for registration integrity test” on page 99).

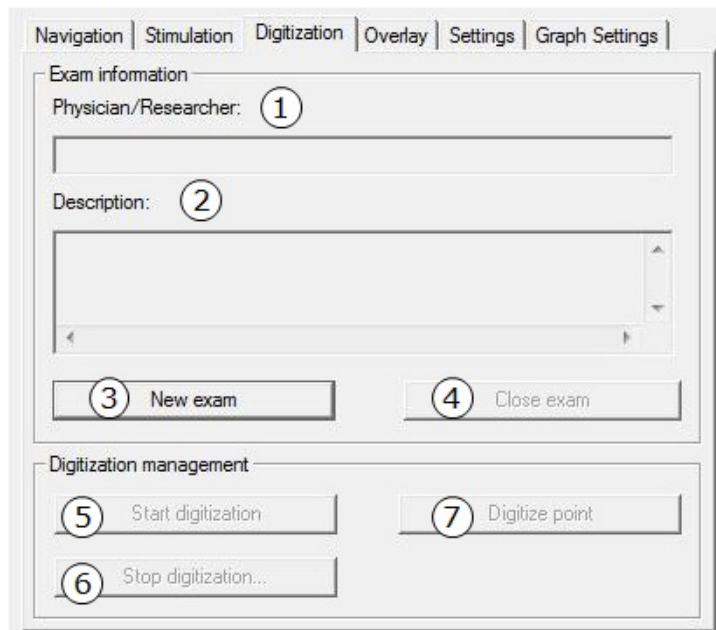


Fig. 55. Digitization-tab

Table 21 Digitization field definitions

1	Physician/Researcher	Type in the name of the researcher or physician performing the exam. The typing field becomes active once <b>New exam</b> is clicked.
2	Description	Type in a description of the exam. The typing field becomes active once <b>New exam</b> is clicked.



Table 21 Digitization field definitions

3	<b>New exam</b>	Creates a new digitization exam in the NBS session tree.
4	<b>Close exam</b>	Closes the current exam. A new exam cannot be created until the current exam has been closed.
5	<b>Start Digitization</b>	Starts the digitization. New sequence is added in the session tree.
6	<b>Stop digitization</b>	Ends the digitization.
7	<b>Digitize point</b>	Click <b>Digitize point</b> or use the left foot switch to record new points (digitizing pen tip locations). This button is enabled when the digitizing pen is visible (indicator is green).

## 5.12 Overlay-tab

The **Overlay**-tab is used for controlling the DICOM export.

### 5.12.1 Load DICOM export -tab

In the **Load DICOM export** -tab you can define the DICOM export visualization. See Figure 56 and Table 22.

For detailed instructions on using the DICOM export, see Chapter 6.16 “Transferring session data to external systems using DICOM export” on page 152.

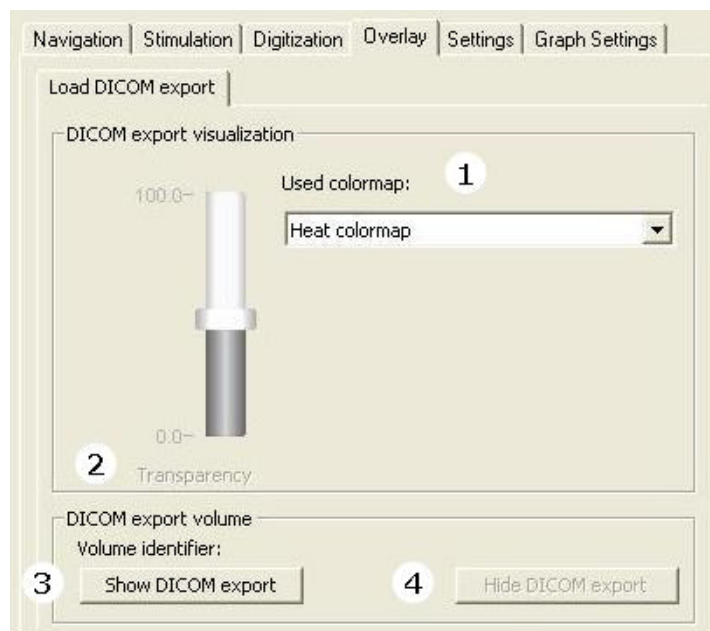


Fig. 56. Load DICOM export -tab



Table 22 DICOM export definitions

1	Used colormap	The colored voxels in the overlaid image shall be colored depending on the selected colormap. See chapters “Heat colormap” and “Rainbow colormap” below.
2	Transparency	The <b>Transparency</b> slider defines the visualization of the colored voxels on the overlaid image. <ul style="list-style-type: none"> <li>• If the slider is set to 0, the loaded images are displayed in full color.</li> <li>• If the slider is set to 100, the images are not displayed.</li> </ul>
3	<b>Show DICOM export</b>	Opens the <b>DICOM export image browser</b> -dialog, where you can select the correct image stack for the session. For more information, see Chapter 6.16.2 “Loading DICOM overlay export” on page 156.
4	<b>Hide DICOM export</b>	Opens the <b>Remove DICOM export</b> -dialog, where you are asked to confirm to hide the displayed DICOM export.

### Heat colormap

The voxels that represent the exported stimulus points are displayed in shades of red, depending on the size of the motor-evoked potential (MEP) that has been associated with a stimulus location. See Figure 57.

Use the Heat colormap when loading DICOM export with the following map settings:

- “Voltage scale”
- “Normalized between min and max”
- “Response On/Off”.



Fig. 57. Heat colormap

### Rainbow colormap

The voxels that represent the exported stimulus points are displayed in specific colors, depending on the channel color of the strongest response (that is, yellow, violet, green, white, blue, dark red and red). See Figure 58.

The voxels that represent the exported stimulus points shall be displayed in a color that varies from blue to red, depending on the response value that has been associated with a stimulus location.

Use the Rainbow colormap when loading DICOM export with the map setting “Channel color of strongest response”.

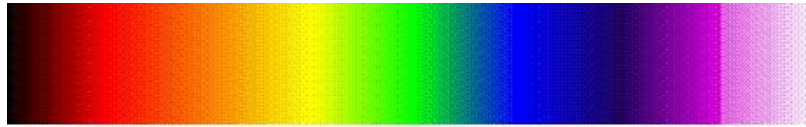


Fig. 58. Rainbow colormap

## 5.13 Settings-tab

In the **Settings**-tab, you can define settings and display information about the system. The **Settings**-tab contains two sub-tabs, **Setup** and **Status**.

### 5.13.1 Setup-tab

In the **Setup**-tab you can define settings for the head tracker and the used coordinate system, as well as the visualization settings for the electric field transparency, coil and position, 3D head, crosshair, and the stimulation target.

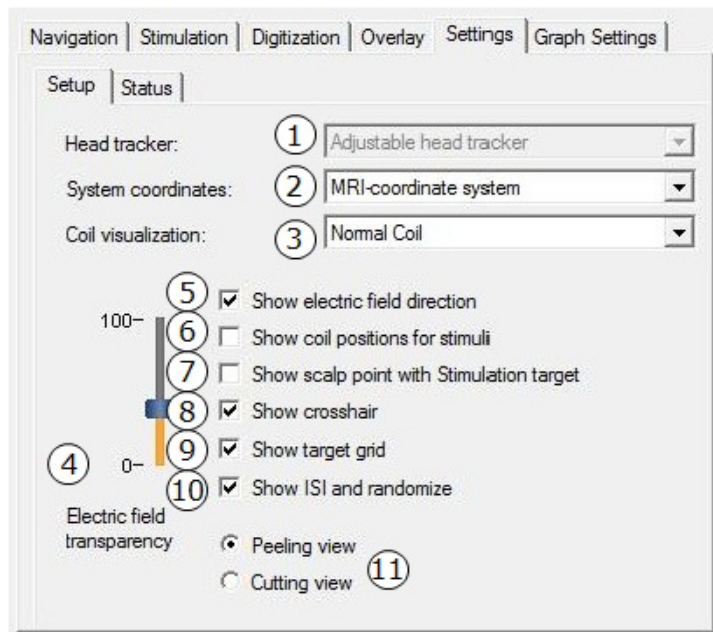


Fig. 59. Setup-tab

Table 23 Settings controls

1	Head tracker	Specifies the reference tool used in the NBS. This can be changed if there is more than one head tracker available. The head tracker can be changed only if the registration is not performed and tracking system is turned off.
---	--------------	--

Table 23 Settings controls

2	System coordinates	<p>Specifies the coordinate system used. You can select between the following:</p> <ul style="list-style-type: none"> <li>• Head coordinate system</li> <li>• MRI-coordinate system</li> <li>• MR scanner coordinate system.</li> </ul> <p>The head coordinate system can be selected if all MRI landmarks have been marked. See Chapter “Coordinate systems” on page 77.</p>
3	Coil visualization	<p>Specifies how the coil is visualized on the 3D head model. The visualization has the following options:</p> <ul style="list-style-type: none"> <li>• <b>Normal coil</b> displays a 3D model coil.</li> <li>• <b>Mini coil</b> displays a 3D model coil in smaller size.</li> <li>• <b>Cylinder</b> displays a cylinder with a coil direction vector and line to the electric field’s maximum.</li> <li>• <b>None:</b> Coil is not visualized; only the electric field.</li> </ul>
4	Electric field transparency	The slider controls the transparency of the colors on the electric field map visualization.
5	Show electric field direction	Sets the display of the direction of the electric field on the hotspot. When this option is selected, the direction of the electric field is visualized as red and blue arrows. (See Figure 94, “Coil placement arrows, indicating direction of the stimulus pulse,” on page 117.)
6	Show coil positions for stimuli	Sets the display of the stimuli. When this option is selected, the coil position is shown as a cylinder with an arrow; also, a line from the coil to the hotspot is visualized. The cylinder with the arrow identifies the coil position and orientation on the scalp.
7	Show scalp point with stimulation target	Sets the display of the stimulation target. When this option is selected, the projection of the stimulation target on the scalp is shown.
8	Show crosshair	Sets the crosshair on the display in MRI slice views and 3D head view.
9	Show target grid	Displays the targeting grid over a stimulation target, when stimulation target is set as active.
10	Show ISI and randomize	When selected, stimuli are delivered with a predefined inter-stimulus interval (ISI). The stimulus interval values are set in the <b>Stimulation &gt; Single pulse</b> -tab.
11	Views	<ul style="list-style-type: none"> <li>• <b>Peeling view</b> displays the 3D head according to the peeling settings set in the <b>Navigation</b>-tab.</li> <li>• <b>Cutting view</b> displays the 3D head according to cutting lines settings. You can set the cutting planes by moving the crosshairs in the MRIs.</li> </ul>

## Coordinate systems

There are three coordinate systems for expressing the location of the coil and stimulus target points:

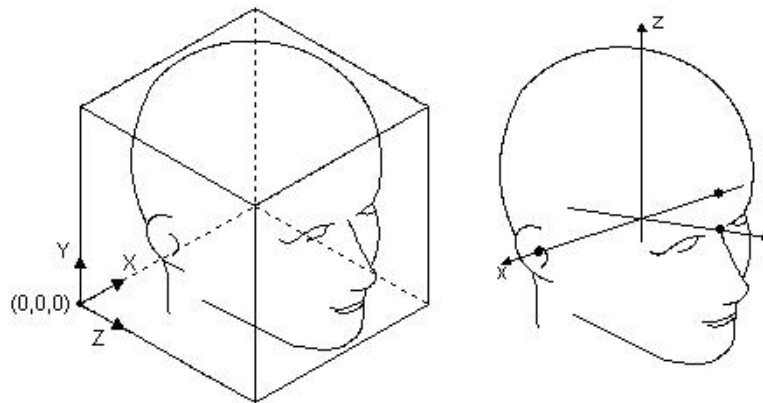
- MRI coordinates, defined from the subject’s MR images.
- Head coordinates, defined from three MRI landmarks pinpointed during registration.

- MR scanner coordinates, defined from the position and orientation of the subject in the MR scanner during the creation of the MR image pack.

The origin of the MRI coordinate space is the bottom corner of the MR image set behind the right ear of the subject (see Figure 60).

- the x-axis points from the origin to the left ear
- the y-axis points from the origin up to the top of the head
- the z-axis points from the origin to the front of the head.

The origin of the head coordinate space is in the middle of the ear landmarks (see Figure 60). The x-axis points from the left ear to the right ear; the y-axis points from the origin to the nose landmark; and the z-axis is orthogonal to x- and y-axis (towards the vertex).



**Fig. 60.** MRI coordinate space and head coordinate space

The MR scanner coordinate system is used in exports, if the user wants to export data that can be compared to the output of other devices. The scanner coordinate system provides a common reference frame for data gathered from various sources.

### 5.13.2 Status-tab

The **Status**-tab shows information about the system. The contents depend on the equipment that is connected to the system. Figure 61 shows an example.



Fig. 61. Status-tab

### 5.14 Graph Settings -tab

The **Graph Settings** -tab is used for setting EMG display parameters and navigating continuous EMG signals.

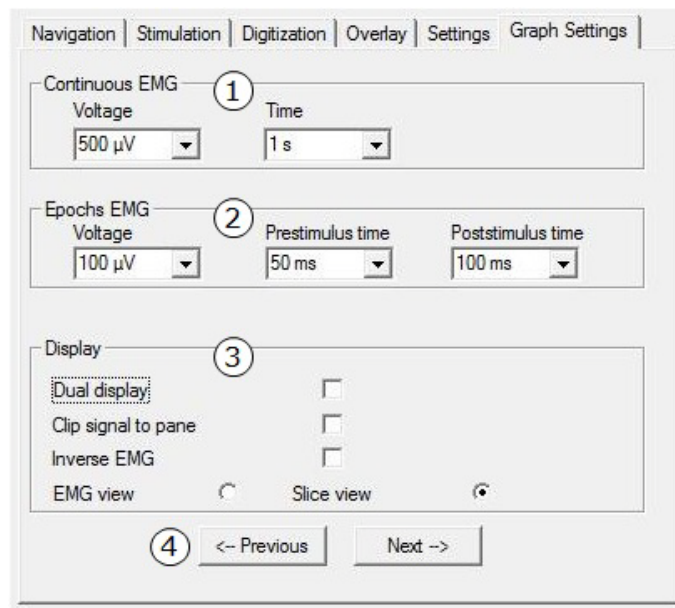


Fig. 62. Graph settings -tab

Table 24 Graph settings controls

1	Continuous EMG	<p>Select the values from the pull-down menus:</p> <ul style="list-style-type: none"> <li>• <b>Voltage</b> defines the voltage level for the continuous EMG signals shown in the continuous EMG view (10 µV - 10 mV).</li> <li>• <b>Time</b> defines the length of the time period visible (50 ms - 10 s).</li> </ul>
2	Epochs EMG	<p>Select the values from the pull-down menus:</p> <ul style="list-style-type: none"> <li>• <b>Voltage</b> defines the voltage level for the EMG signals shown in the epochs EMG view (10 µV - 10 mV).</li> <li>• <b>Prestimulus time</b> defines the time shown in the epochs EMG view preceding the TMS stimulation pulse in milliseconds.</li> <li>• <b>Poststimulus time</b> defines the time shown in the epochs EMG view after the TMS stimulation pulse in milliseconds.</li> </ul>
3	Display	<ul style="list-style-type: none"> <li>• Check the <b>Dual display</b> to use two displays (one for NBS and one for EMG display). This is checked by default. If unchecked, the <b>EMG view</b> and <b>Slice view</b> options can be used to switch between each other in the NBS display.</li> <li>• <b>Clip signal to pane</b> limits the display of peaks of an EMG response within the pane allocated to each EMG channel.</li> <li>• Check the <b>Inverse EMG</b> to flip the EMG measurement peaks in the EMG display. Unchecked by default (positive signals up).</li> </ul>
4	Stimulus navigation	<p>When EMG measurement is switched off (the EMG device is in “Not connected” or “Connected” state), continuous EMG signals can be browsed using the <b>&lt;--Previous</b> and <b>Next--&gt;</b> buttons.</p> <p>In “Measuring” and “Recording” states these buttons are not active.</p> <p>When these buttons are clicked, the signal data is moved half of the duration of the viewed signal data along the time axis in the direction selected.</p>

## 5.15 EMG display

Figure 63 shows an example of the EMG display.

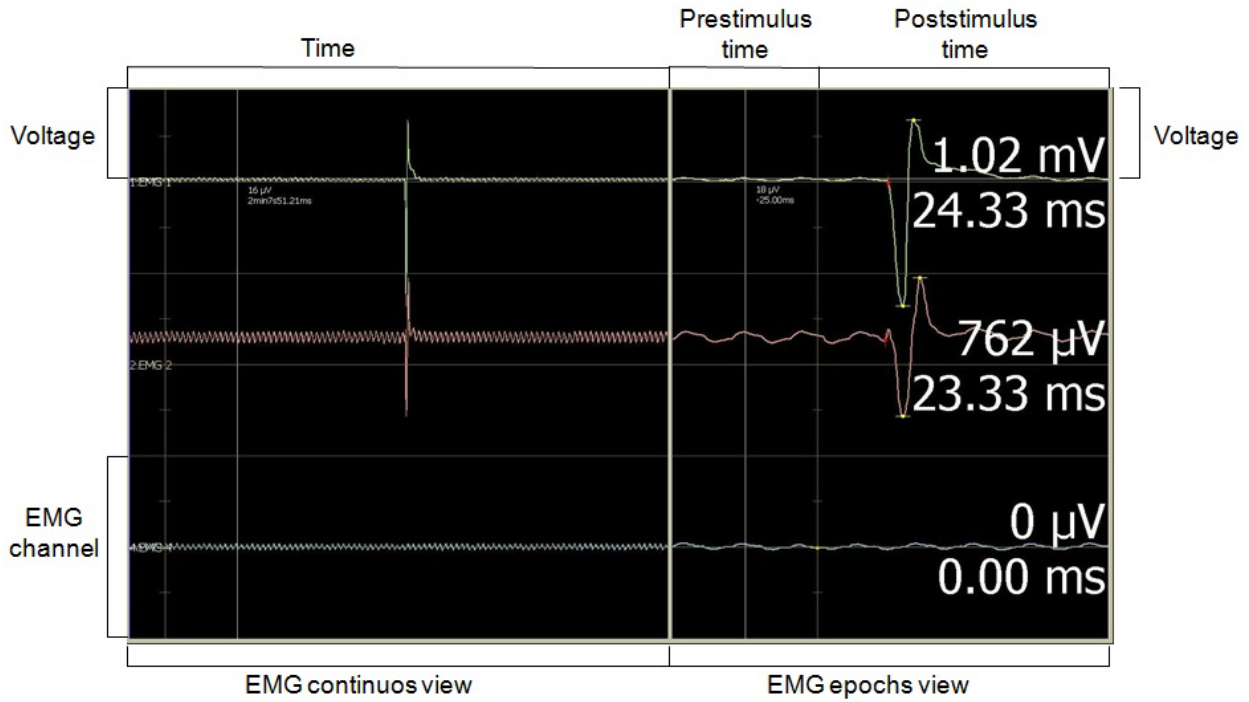


Fig. 63. EMG display

The EMG display is divided into two views, the constantly updating continuous EMG view and the epochs EMG view, displaying specific EMG response events.

The voltage and time parameters are set using the **Graph Settings** -tab.

## 5.16 Session file directories

All session data is stored under a specific session directory:

*C:\Nexstim\NBS 4.3\NBSSessionfiles\[session directory name].*

The **session directory** contains session files and other session information. It includes the subfolders described in Table 25.

Table 25 Nexstim NBS session file directories

Directory name	Directory description
DICOMExport	Directory that contains DICOM export generated from the session <ul style="list-style-type: none"> <li>• <i>[DICOM export directory name]</i>: Directory that contains all information generated with one DICOM export command. This directory is intended to be copied to the external system.               <ul style="list-style-type: none"> <li>- <i>DICOMFiles</i>: Directory that contains DICOM image files of the DICOM export.</li> <li>- <i>[DICOM export directory name].txt</i>: DICOM text export file that describes the content of the DICOM export. Used for checking that the external system displays correct DICOM export correctly.</li> </ul> </li> </ul>
OriginalImage	Directory that contains image file(s) of the image from which the session is created. If the original image is in DICOM format, the directory contains only the files belonging to the series that was used from creating the session.
Screenshot	Directory that contains normal and DICOM screen captures generated from the session.
TextExport	Directory that contains text exports.



## 6 Using the Nexstim NBS software

This chapter gives instructions on how to use the Nexstim NBS software.

---



### WARNING:

Do not install any software in the NBS computer or change the BIOS/Windows settings.

The settings of the Windows operating system have been set by Nexstim to optimize the performance of NBS software. This includes also the personalization settings. Changing the settings may affect the functionality of NBS software.

Third party software can cause unexpected malfunctioning of the NBS software.

Nexstim takes no responsibility for malfunction if third party software has been installed or the BIOS/Windows settings have been changed.

---



### PRECAUTION:

Do not connect the Nexstim NBS System to network. A network connection may cause unstable operation of the NBS software.

To minimize the risk of data loss, back up session files after each measurement session.

---

### NOTE:

After installing the NBS software and the license key, do not remove the license key from the computer's USB port.

Never use other programs simultaneously with the NBS software.

Never use the CD-writer simultaneously with the NBS software.

NBS software does not include a **Save** -button. Instead, the data is automatically saved when:

- a new session is created
  - a session is closed
  - NBS software is closed.
  - a single-pulse sequence is stopped.
-

## 6.1 Prerequisites for using the NBS software

### 6.1.1 Handling MR images

#### Acquiring MR images

Before you can use Nexstim NBS, you need to acquire the MR images of the patient and load them to NBS. Acquire good quality MR images comprising of the whole head so that ears, nose, and the head surface are all clearly visible. Preferably use an MRI visible marker on one side while acquiring the MR images.

---

**NOTE:**

Do not use visible hearing protection inside the MR scanner.

---

Table 26 MR image requirements

<b>Field of view (FOV)</b>	<ul style="list-style-type: none"> <li>• Neither the scanning table or headrest should be included in the FOV.</li> <li>• MRI markers and landmarks must be included in the scan (if used).</li> <li>• The forehead, eyes, ears and entire nose (the tip of the nose must not be cropped) must be included in the scan.</li> <li>• There must be no markers over the face, or ears of the patient (if needed, a marker may be used on the chin of the patient).</li> </ul>
<b>Scan attributes</b>	<ul style="list-style-type: none"> <li>• T1-weighted images required.</li> <li>• 3D MR scans may be used.</li> <li>• Voxel size 0.9 - 1.1 mm. 1x1x1 mm recommended.</li> <li>• Sagittal images are recommended, axial and coronal images are supported.</li> <li>• Sequential scans of 1 mm thickness and 0 mm slice gap required.</li> <li>• Pixel size, matrix size and table position must not be altered during the scan.</li> </ul>
<b>Suggested 3D T1 sequences (scanner specific)</b>	<ul style="list-style-type: none"> <li>• Siemens: MPRAGE</li> <li>• GE: SPGR</li> <li>• Philips: T1-FFE or TFE</li> <li>• Acquire anatomical images without using sensitivity encoding (SENSE) technique because the scanner reconstruction algorithm removes noise and modifies the image gray scale histogram used by the NBS System.</li> </ul>
<b>Angulation</b>	<ul style="list-style-type: none"> <li>• Positive and negative values may be used, but must not be altered during the scan.</li> <li>• Angulation should be less than +/- 10 degrees.</li> </ul>
<b>Patient orientation</b>	Head first, supine. Make sure that the patient scalp is as smooth as possible (no wrinkles in the skin caused by a headrest, for example).
<b>Image compression</b>	Save the MRI data on a CD-ROM in uncompressed format.
<b>Format</b>	DICOM format is recommended. Analyze and NIFTI formats are supported.

<p><b>DICOM file meta information</b></p>	<p>Every DICOM file shall include identifying preamble information on the encapsulated data set. The DICOM file s header consists of:</p> <ul style="list-style-type: none"> <li>• a 128-byte file preamble</li> <li>• a 4-byte DICOM prefix, and</li> <li>• the file meta elements.</li> </ul>
---	---

## Loading MR images for the use of Nexstim NBS



**WARNING:**

In some cases, the actual anatomy of the brain may differ from the MR images. Hence, always evaluate the validity of the MR images.



**PRECAUTION:**

It is very important that there are no wrinkles or skin folds on the patient’s scalp (due to a headrest, for example) during the MR imaging or during stimulation. If there is a discrepancy in the patient’s head surface between the MR imaging and NBS head registration there will be inaccuracies in TMS stimulation.

**NOTE:**

The patient name is read from the MR image. Renaming the file does not have any effect.

Copy the MRI stack into the following directory: *C:\Nexstim\NBS 4.3\MRI\_DATA*.

To avoid accidental use of another person’s MR images, name the patient files in a unique fashion (for example, name and date of birth). In addition, store the MRI stacks so that one set of images of one subject is in one folder. You can structure the folders inside the *MRI\_DATA* folder according to your own needs.

## 6.2 Starting the NBS software

1. Open the NBS computer and log on.
2. Start the Nexstim NBS software by clicking on the Nexstim NBS icon on the desktop, or from the **Start**-menu by selecting **All Programs > Nexstim > Nexstim NBS > Nexstim NBS 4.3**.
3. The NBS start-up screen appears, displaying the name, version number, and the software licence number.
4. Nexstim NBS System main view opens (see Figure 29 on page 45).

## 6.3 Closing the NBS software

Click **Quit** to close the NBS software. (See Chapter 5.1 “NBS session controls” on page 46.)  
If you have a session open, you are asked to confirm the command to close.

---

**NOTE:**

Closing the NBS software is not possible when NBS processes are running.

---

## 6.4 Creating a new session

A session is always patient-specific.

1. Click the **New session** -button on the bottom left corner of the NBS display.
2. The **New session** -dialog opens (see Figure 64).

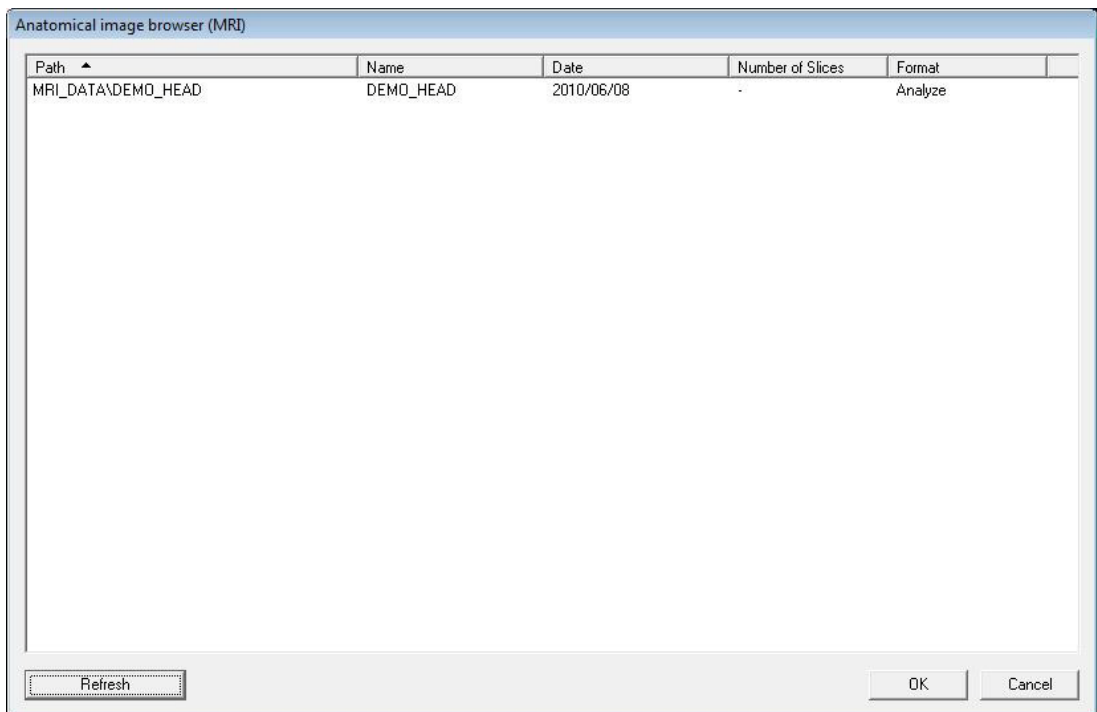
The 'New session' dialog box contains the following fields and options:

- General:**
  - Physician/Researcher: [Text input field]
  - Organisation: [Text input field]
  - Description: [Multi-line text area]
- Patient:**
  - Name: [Text input field]
  - Patient ID: [Text input field with '0']
  - Age: [Text input field with '0']
  - Gender:  Male,  Female
  - Handedness:  Right-handed,  Left-handed
  - MRI stack: [Text input field]
  - MRI crust threshold (0 = auto): [Text input field with '0']

Buttons:

**Fig. 64.** New session -dialog

3. Fill in the following information on the researcher and patient:
  - The researcher's name
  - Organization
  - Description of the session
  - Patient's name (characters \/:\*?"<>| are not allowed).
  - Patient's ID, age, and gender
  - Handedness of the patient.
4. Load the patient's MRI stack by clicking the **Browse...** -button.
5. The **Anatomical image browser (MRI)** -dialog opens (see Figure 65).



**Fig. 65.** Anatomical image browser (MRI) -dialog

The dialog shows the images that were in the *MRI\_DATA* folder during the Nexstim NBS software start-up (or since the last refresh function). Each package shows the name of the subject, the date it was acquired, the number of slides included in the stack (except in Analyze and NIfTI format stacks), and the image format. Supported formats are DICOM, Analyze, and NIfTI.

If you have loaded images after the Nexstim NBS software start-up and want to see those images in the Anatomical image browser view, select **Refresh**.

6. From the displayed list, select the correct MRI stack for the session. To sort the list, click **Path**, **Name** or **Format** on the dialog bar. A small arrowhead indicates the sorting order.

7. Click **OK** to confirm the MRI stack selection. The view returns to the **New session** dialog.
8. Set the MRI crust threshold value that is used for creating the 3D head from the MR images (usually between 10 and 20). The default value is 0, which means that the software determines the actual value automatically based on individual image data.
9. Click **OK** (or **Cancel**).
10. The NBS starts to generate the 3D head view. This may take some time.  
The output of the creation, MR slice images (sagittal, coronal, and axial), and the 3D head constructed from the MR images are visible in their own window and the patient's information is visible in the session tree.
11. Check that the 3D head is not deformed (for example, there are no bumps or holes in the 3D head).

---

**NOTE:**

It is very important that the 3D head appears smooth and is of good quality. Any wrinkles or skin folds appearing on the 3D head model will cause errors in stimulation.

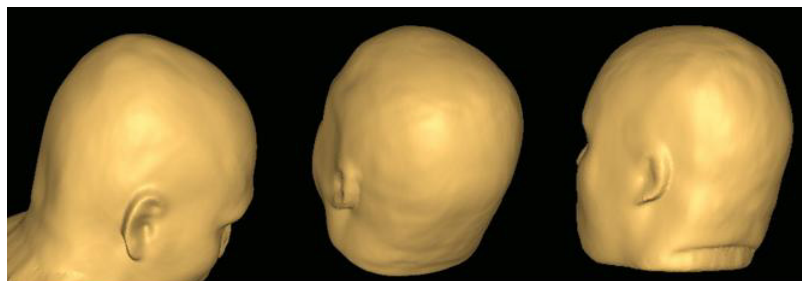
---

12. Verify the orientation of the MR images.
13. Check that the 3D head model corresponds to the patient's physical head and that MRI information corresponds to patient data. Also ensure that the 3D head has the correct left-right orientation (in Analyze format). Also check that the coronal orientation is correct. If the orientation is wrong, the MRI landmarks cannot be set.

### Examples of the 3D head quality

Images of good quality are smooth and correspond to the patient's physical head as closely as possible. Images of bad quality show wrinkles and skin folds on the 3D image surface.

A poor 3D image can be caused, for example, by poor MR image quality or wrinkles in the subject's scalp, (from a headrest, for example). A poor 3D image has a direct effect on the calculation of the electric field.



**Fig. 66.** Good quality 3D head images

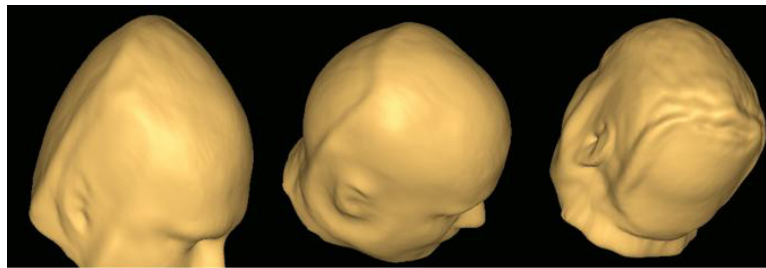


Fig. 67. Bad quality 3D head images

## 6.5 Opening a previously created session

1. To continue a former NBS session for a specific patient, click the **Open session** -button on the bottom-left corner of the NBS display.
2. Open the specific session from the *NBS.Sessionfiles* folder.
3. Wait until the patient’s MR scan images, the 3D head constructed from the MR images and the session tree become visible. The session tree shows all data from the session.

If you are opening a session that has been created using an older version of NBS software, refer to Chapter 6.17 “Using old session files” on page 160.

## 6.6 Closing a stimulation session

1. Select **Close session** to end the active session. The **Close session** -dialog opens.

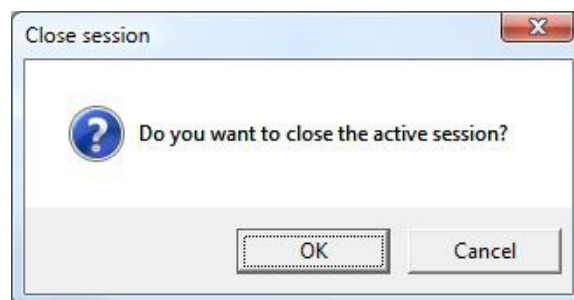


Fig. 68. Close session -dialog

2. To close the session, click **OK**.

When the session closes, the session data is also automatically exported. The automatic export produces *.nbe* and *.nbx* files to the *NBSExportFiles* directory.

The session is saved to the *NBSSessionfiles* directory in a session-specific directory that is created when the first session is saved. The name of the directory is generated as follows: the first 45 characters (maximum) of the patient's name + date + time (for example, *John Smith\_2011\_09\_10\_16\_40\_22*). The session file name is generated in the same way; the extension *.nbs* is added.

If old sessions are used, they are saved directly under the *NBSSessionfiles* directory.

---

**NOTE:**

Closing a stimulation session is not possible when NBS processes are running.

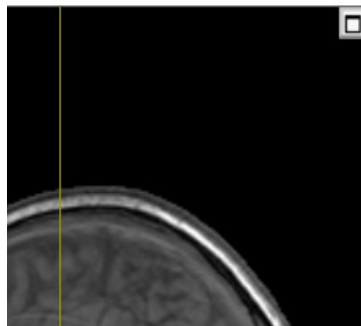
---

## 6.7 Adjusting MR images on the NBS display

### 6.7.1 Adjusting, zooming, panning, and rotating the MR images

#### Enlarging the window

1. Click the small box on the top right corner of the image to enlarge the image. This helps when you need to see a single image in detail.
2. To return to the default NBS display, click the top right corner box again.



**Fig. 69.** Click the box to enlarge the MR image

The small box is found on 3D head, Aiming Tool, and all MRI views.

#### Adjusting the image contrast

1. Place the mouse cursor over the MR image or 3D head.
2. Hold the mouse roller down and
  - a) Move the mouse left to decrease contrast.
  - b) Move the mouse right to increase contrast.



## Adjusting the image brightness

1. Place the mouse cursor over the MR image or 3D head.
2. Hold the middle mouse roller down and
  - a) Move the mouse up to reduce brightness.
  - b) Move the mouse down to increase brightness.

Note that increasing the brightness may cause the MRI stack borders to become visible around the MR image.

## Zooming the MRI slices and 3D window

1. Select **Zoom (F3)** or press F3. (See Chapter 5.2 “Navigation and display controls” on page 46.)
2. Left-click the mouse to zoom in and right-click to zoom out.

## Panning

To click and drag MRI slices and 3D window within its window:

1. Select **Pan (F2)** or press F2. (See Chapter 5.2 “Navigation and display controls” on page 46.)
2. Left-click the mouse to hold part of the image and move it in the desired direction in the window.

## Rotating the 3D head

Select **Rotate (F4)** or press F4. (See Chapter 5.2 “Navigation and display controls” on page 46.)

- a) By holding the left mouse button down and moving the mouse in any direction, the window contents rotate in the same direction relative to the centre point of the head.
- b) By holding the right mouse button down and moving the mouse to the left, the contents of the window rotate anticlockwise relative to the centre point of the head. Correspondingly, when moving to the right the contents turn clockwise.

## Restoring the window's original settings

1. Select **Original (F5)** or press F5. (See Chapter 5.2 “Navigation and display controls” on page 46.)
2. Rotation, zoom, panning, and the crosshair cursor return to their original states.

## 6.7.2 Selecting visualized items on the 3D head

To select these individual objects (such as stimuli, digitization points, and target) from the 3D head, press the left mouse button over the target.

To select several objects, hold down the CTRL key and click the left mouse button. You can also select objects from the session tree (see Chapter 6.13.2 “Selecting items in the session tree” on page 125).

## 6.8 Performing registration

---

### NOTE:

Registration is a sensitive procedure that may cause major inaccuracy. It is essential that you understand the registration function and that you always perform it carefully.

---

### 6.8.1 Setting MRI landmarks

If you are opening a previous session with already registered MRI landmarks, go directly to Chapter 6.8.2 “Digitizing nasion and ear landmarks on the scalp”.

1. Check that the **Tracking unit state** indicator is bright green. (See Chapter 5.2 “Navigation and display controls” on page 46.)
2. Select **Perform Registration...** in the **Navigation**-tab. The **Registration**-dialog opens.

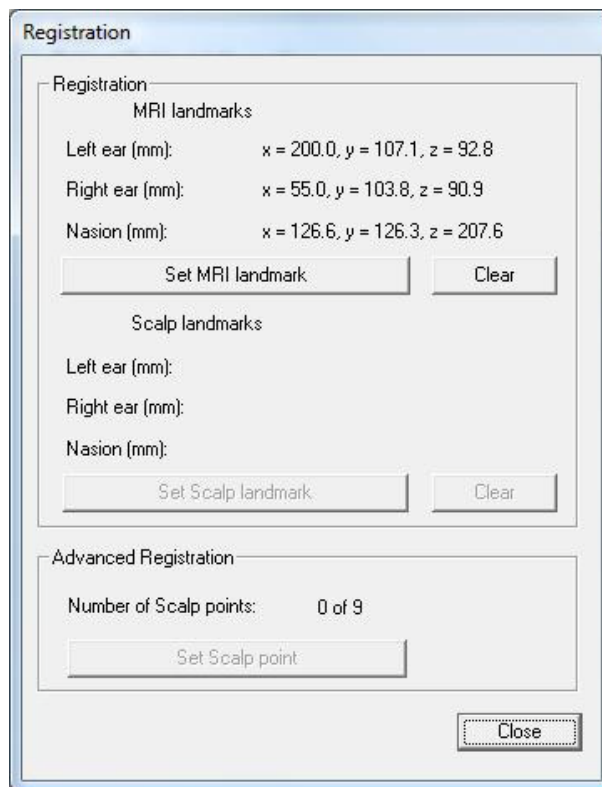


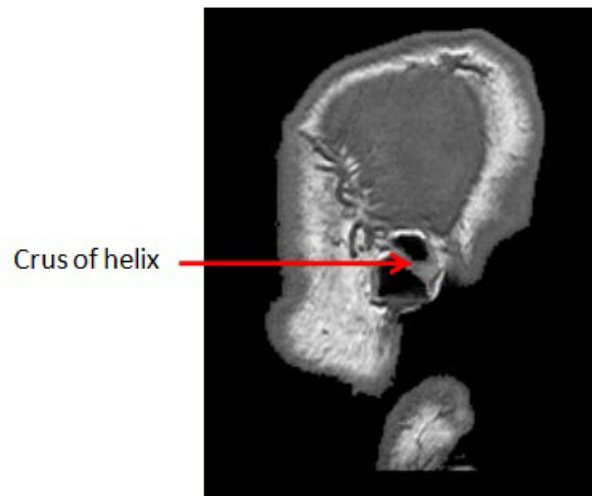
Fig. 70. Registration-dialog after MRI landmarks have already been registered

3. Select **Crosshair** to register the MRI landmarks for the nasion and ear points.
4. Move the crosshair over the MR image to find the correct position for the MRI landmark.
5. Select **Set MRI landmark** to accept the landmark.
6. Check that the landmark is registered as a red cross on the MR image.
7. Repeat these steps for all three landmarks.

### Finding correct positions for the nasion and ear landmarks

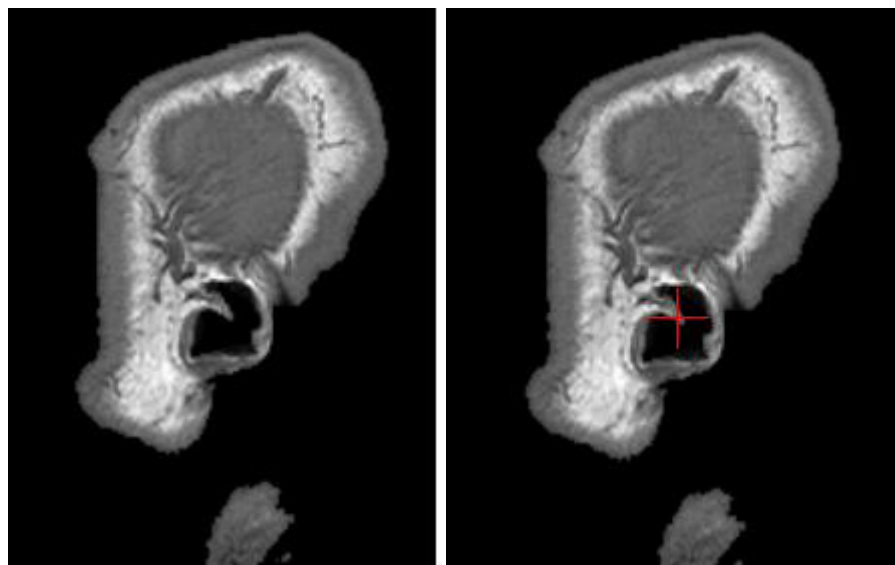
The correct position for the ear landmarks can be found by observing the sagittal MR image.

1. It is easiest to start by placing the crosshair slightly inside the auricle so that the crus of helix is seen completely bridging diagonally across the ear as shown in Figure 71.



**Fig. 71.** Crus of helix bridging the ear

2. Move the crosshair slightly outwards until only the highest part of the crus of helix is visible and no longer completely bridging the ear as shown in Figure 72. The landmark position is at the tip of visible crus of helix. Note that you have to locate this position for both the left and right ear landmarks.



**Fig. 72.** Highest part of the crus of helix, and MRI landmark location

3. The correct position for the nasion landmark is simply the lowest position of the nasion, it is easiest to find by viewing the sagittal and coronal MRI images, as shown in Figure 73.

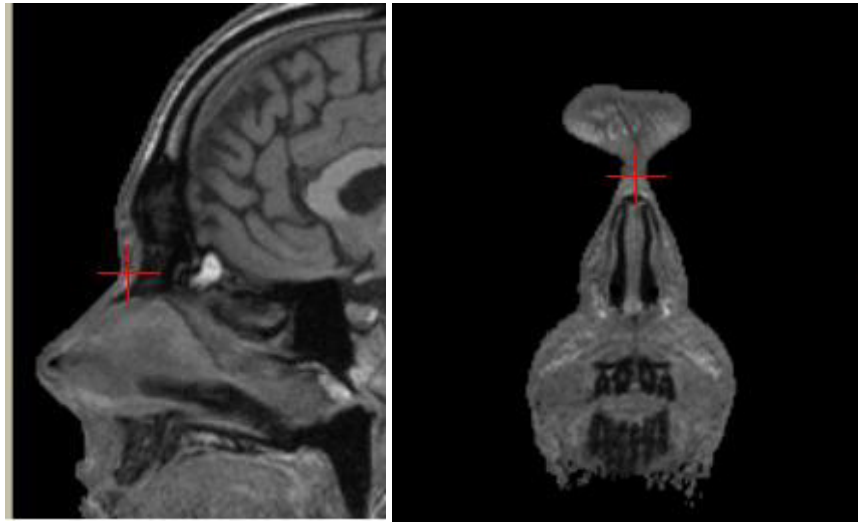


Fig. 73. Nasion landmark location sagittal and coronal MRI views

### 6.8.2 Digitizing nasion and ear landmarks on the scalp

After setting the MRI landmarks, you have to digitize **exactly the same three points** on the scalp that are marked in the MR images (see Figure 74). Otherwise, a major systematic error may appear in the navigation results.

It is recommended to digitize the nasion landmark first, as digitizing the nasion landmark may cause the head tracker to move slightly.

1. Ensure that the **Registration**-dialog is open and contains the MRI landmarks (as in Figure 70).
2. Take the digitizing pen on the top of the patient's head and check that the **Digitizing pen** and **Head tracker** LED indicators are green.
3. Point the nasion landmark with the digitizing pen. Touch the scalp carefully; the pen is rather sharp.

See Figure 74 for the recommended use of digitizing pen to register head landmarks. Stand behind the patient, and hold the pen so that the markers are visible to the tracking system.



Fig. 74. Registering the nose and ear landmarks

4. Press the left pedal on the foot switch and check that the landmark is registered on the **Registration**-dialog.
5. Repeat the steps for both ear landmarks (crux helix).



Fig. 75. Location of the ear landmark

If the registration mismatch is greater than allowed, a notice appears on screen, and you must repeat the registration of scalp landmarks.

6. Continue directly to advanced registration (described in Chapter 6.8.3 “Performing advanced registration”), OR

Verify the registration (described in Chapter 6.8.4 “Verifying the registration”), OR

Select **Close** to exit the dialog and save the registration.

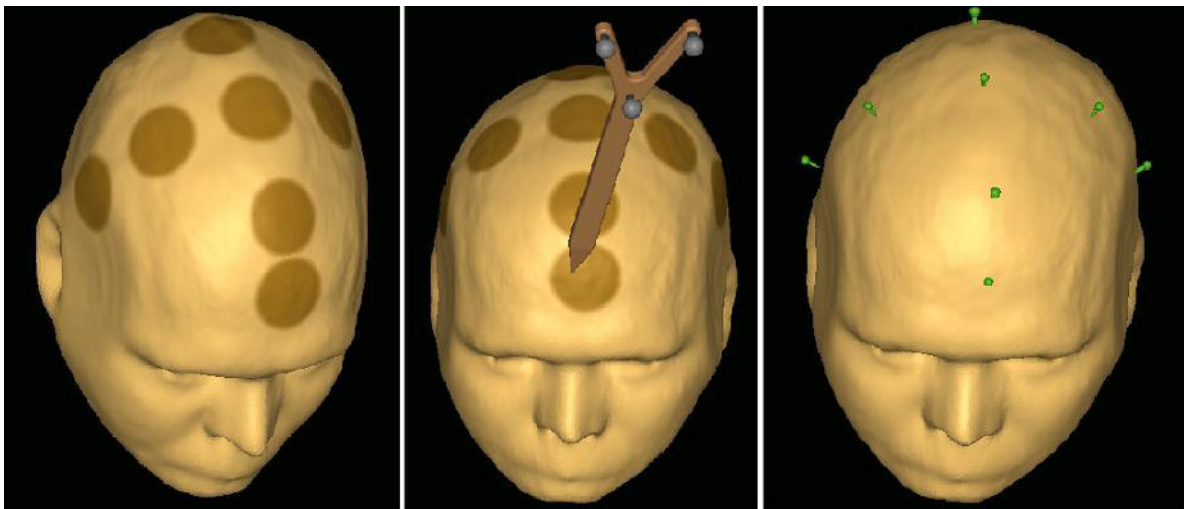
### 6.8.3 Performing advanced registration

**NOTE:**

Although advanced registration is not mandatory for a stimulation session, it improves accuracy and is therefore recommended.

After you have completed the previous procedures described in Chapters 6.8.1 and 6.8.2, continue to advanced registration.

1. Digitize all nine scalp points displayed on the screen by pointing the guiding area with the digitizing pen. Ensure that you actually touch the scalp with the tip of the pen and not floating above the scalp (for example, because of thick hair). But be careful; the pen is rather sharp.
2. When the tip of the pen is at the guiding area, the area starts to blink and the scalp point can be saved.
3. Press the left pedal on the foot switch to save the scalp point. Scalp points can be saved in any order.
4. Check that the scalp point is registered: the brown guiding area has been replaced by a green digitized point symbol at the point of the digitizing pen (see Figure 76 ).



**Fig. 76.** Advanced registration

5. Repeat the steps for all scalp points.  
If the registration mismatch is greater than allowed, a notice appears on screen, and you must repeat the advanced registration.
6. Verify the registration (described in Chapter 6.8.4 “Verifying the registration”), OR Select **Close** to exit the dialog and save the registration.

## 6.8.4 Verifying the registration

### NOTE:

The registration must always be verified before closing the **Registration**-dialog and starting the stimulation. The three-point and advanced registration are verified in the same way.

Always verify the registration, even if the **Registration performed** indicator is green.

1. Move the digitizing pen over the scalp. Check from the NBS display that the tip of the pen moves correspondingly over the scalp in the 3D head view (Figure 77).



Fig. 77. Verifying the registration

The NBS display should not show the pen tip going inside the head or not touching the scalp (as shown in Figure 78).

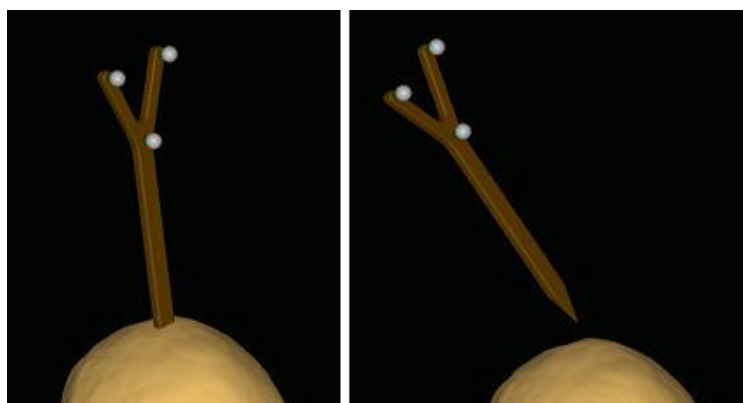


Fig. 78. Incorrect registration

2. Turn and zoom the 3D head view to verify the registration from different angles.



## 6.8.5 Creating reference points for registration integrity test

The aim of the registration integrity test is to check the validity of registration at any time during the session.

---

### NOTE:

Because reference points are used to ensure that the performed registration is valid (that is, they are registration-specific), they must be created every time you perform registration.

When clearing the registration or closing the session, you may delete the digitization exam containing the reference points, as they should not be used in the registration integrity tests.

---

1. Attach the registration sticker to the patient's forehead.
2. In the **Digitization**-tab, select **New Exam**.
3. Enter the researcher's name and a description of the exam. They are displayed in the tree structure and the new exam is automatically selected as the active exam.  
It is recommended to describe the exam so that it can be linked to the most recent registration. For example, mention the reference points and enter the date and time of the registration.
4. Click **Start digitization** to start digitization. Navigation is automatically switched on and a new sequence is added in the session tree.
5. Check that the digitizing pen is visible. Using the digitizing pen, place one digitization point on one corner on the registration sticker.
6. Press the left pedal on the foot switch or select **Digitize point**.
7. Check that the result is added to the session tree.
8. Repeat steps 5 -7 for all three corners of the registration sticker.
9. The digitization points will be displayed on the 3D head view (see Figure 79).

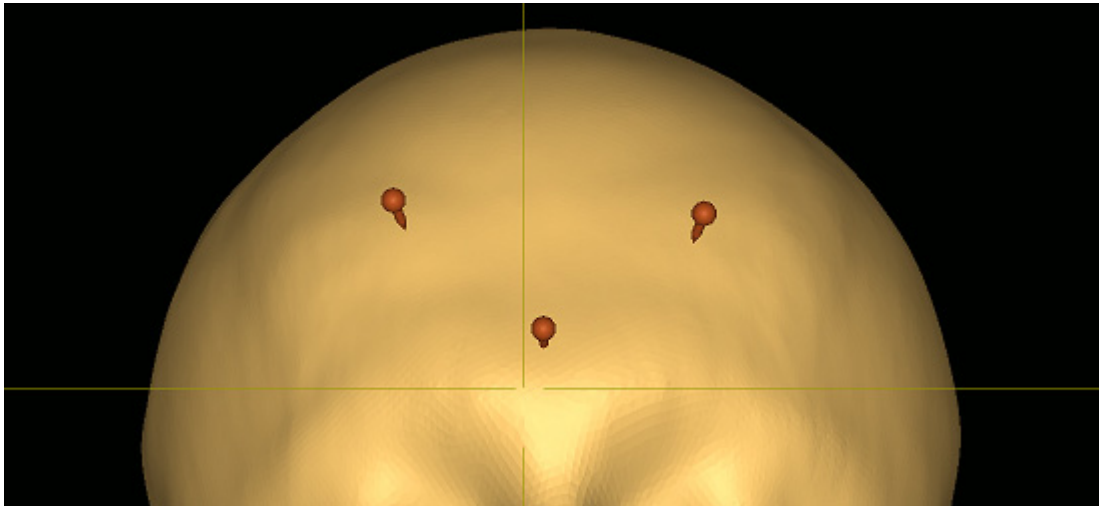


Fig. 79. Digitization points displayed on the 3D head

---

**NOTE:**

After successful digitization, the digitization point is stored under the active digitization exam. Its exact location with accuracy of 0.1 mm is shown in the digitization point.

The number of points in the active digitization exam is updated after every digitization.

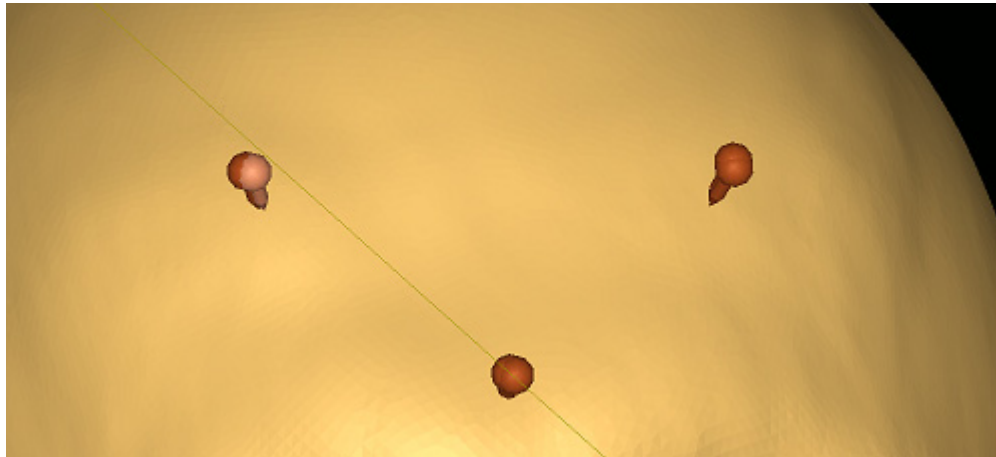
---

10. To stop the digitization, select **Stop digitization**.

### 6.8.6 Performing the registration integrity test

Movement of the head tracker between registrations may cause inaccuracies in locating the stimuli in NBS. The registration integrity test is used for detecting whether registration has become invalid due to movement of the head tracker array relative to the patient's head. (In case of perceptible movement, the user can initiate re-registration immediately without using the detection procedure.)

1. Create a new digitization exam and place a digitization point on each of the three markers on the registration sticker.
2. Compare the digitization points with the points in the digitization exam containing the reference points for this registration. The registration is valid if the digitization points of the first and second digitization exams are in contact, that is, overlap (partially or fully). See Figure 80.



**Fig. 80.** Checking the registration integrity

If the digitization exams do not match (as shown in Figure 81), then the relationship has changed due to the movement of the head trackers, and the registration has become invalid. In this case, the accuracy of the stimulation sequence results cannot be guaranteed.

If so, the results must be discarded, and you have to perform this procedure again.



**Fig. 81.** Digitization points do not match

## 6.8.7 Clearing the registration

If you select **Clear** in the **Registration**-dialog, the set scalp landmarks and advanced registration points are erased and you can restart registration.

- Select **Clear** on the top of the dialog to erase all registration data.
- Select **Clear** in the middle of the dialog to erase scalp landmarks and advanced registration points.

You may delete the digitization exam containing the reference points, as they are registration-specific and should not be used in the registration integrity tests.

## 6.9 Checking the coil tracker accuracy

---

**NOTE:**

It is recommended to regularly check the accuracy of the stimulation coil tracker.

To ease the accuracy determination, we recommend selecting **Coil visualization** as a **Cylinder** in the **Setup**-tab (see Chapter 5.13.1 on page 76). The cylinder radius is 3 mm and the diameter is 6 mm.

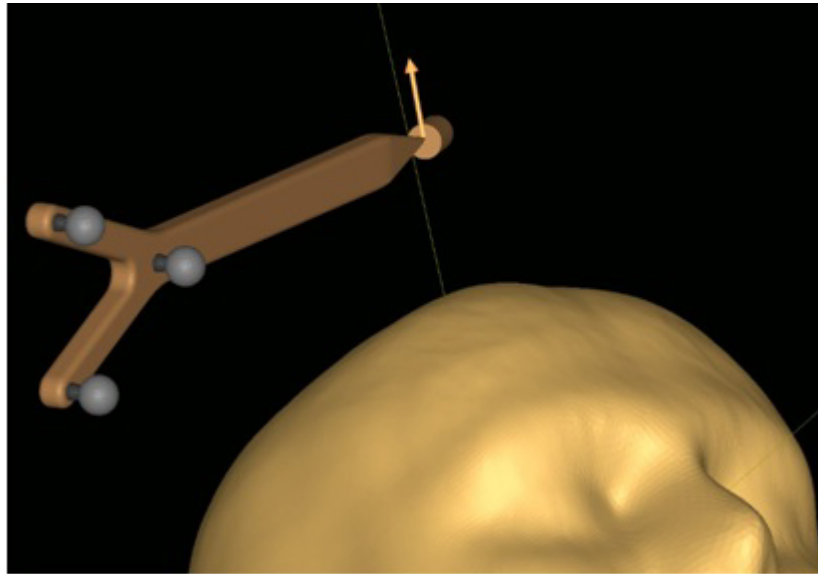
---

1. Start the NBS software and create a session (for example, for the demo head) and perform registration.
2. Set the 3D model of the coil visible in the NBS.
3. Enlarge the 3D head window. (See Chapter “Enlarging the window” on page 90.)
4. Rotate the view so that the bottom of the coil is seen (as in Figure 82 and Figure 83). (See Chapter “Rotating the 3D head” on page 91.)
5. Place the coil on top of the head so that one of the coil tracker elements (the tracker consists of four tracker elements) is facing the tracking unit.
6. With the digitizing pen, carefully point to the checkpoint carved on the bottom of the coil.
7. In the NBS display, check that the tip of the pen is at the checkpoint (at the bottom of the coil). If the tip is outside the checkpoint, the tracker may have moved with respect to the coil. Another possibility is that the markers of the tracker element or the digitizing pen are damaged or dirty. Replace the markers if necessary.
8. In the display, check that the digitizing pen point differs less than 3 mm from the coil checkpoint.  
See Figure 82 and Figure 83 as examples of coil visualization settings **Normal coil** and **Cylinder**.
9. Repeat these steps for the three other coil tracker elements.

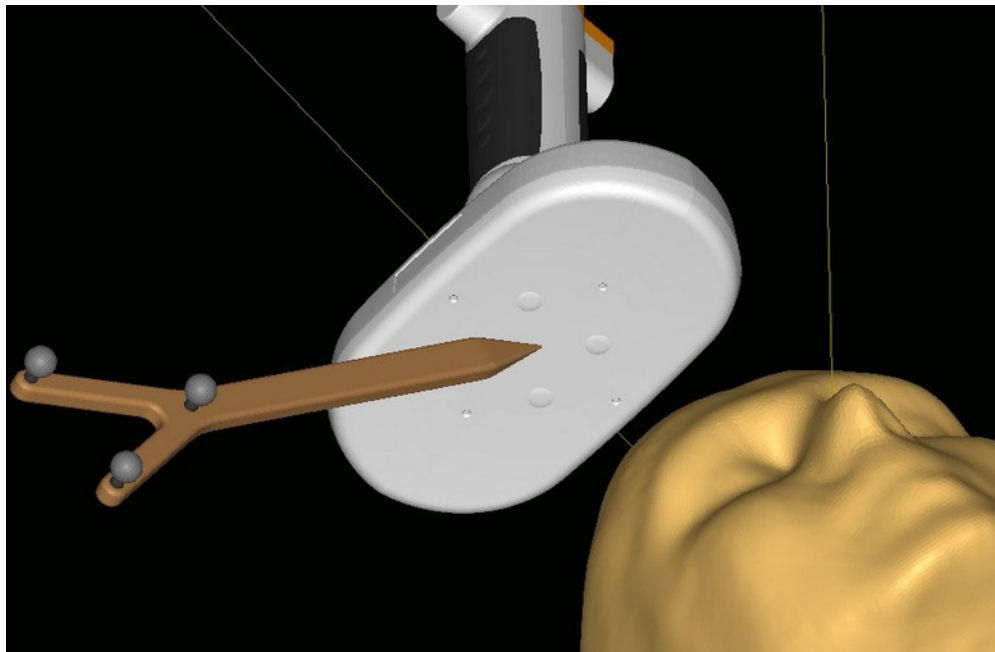
**NOTE:**

The 3 mm error range includes both the digitizing pen and the coil tracker error.

---



**Fig. 82.** Coil tracker accuracy check (Cylinder visualization)



**Fig. 83.** Coil tracker accuracy check (Normal coil visualization)

## 6.10 Using Nexstim EMG

---

### NOTE:

The functions described in this chapter cannot be performed during Defined series or repetitive stimulation.

---

### 6.10.1 Performing EMG measurement

Nexstim EMG is operated through the **EMG**-tab (described in Chapter 5.10.1 on page 58).

1. Attach the EMG electrodes to the patient. (See page 39 for instructions.)
2. If the EMG is not connected, click the **Connect**-button in the **EMG**-tab.
3. Name the EMG-channels by writing the names in the text box. You may enter, for example, to which muscle the EMG-channel is connected.

The channel names are shown in the EMG display. Each EMG channel has a different color.



**Fig. 84.** Example of EMG channels displayed on the EMG continuous view

4. Select the channels used in EMG measurement using the **In use** -check boxes on the **EMG**-tab.
5. Adjust the Response Detection settings. See the following chapters for detailed instructions.
6. Start the EMG measurement by clicking **Start EMG** on the **EMG**-tab. The continuous EMG view is activated, showing the responses of the selected channels.
7. Check the signal interference level and ensure that the channels needed are connected. You may also adjust the signal display settings on the **Graph Settings** -tab. See the following chapters for detailed instructions.

8. To stop the EMG measurement, click **Stop EMG**.

---

**NOTE:**

To adjust signal display settings, you may need to deliver few single pulses to ensure correct display of patient-specific values.

---

## 6.10.2 Adjusting Response Detection settings

Response Detection helps the user at runtime by removing unfitting responses, as the markers are drawn only when the detected response fits the detection settings. Response Detection uses limits for the response variable. Both, none, or one may be in use.

1. In the **EMG**-tab, click **Response Detection...** to open the **Response Detection** -dialog. (For dialog description, see page 59.)
2. Select the filters you wish to use.
3. Set the limits (minimum and maximum latency and amplitude threshold values) for the response by entering values to the edit fields or using the sliders. (For more information, refer to Table 12, “Response Detection -dialog definitions,” on page 60.)
4. Click **OK** to save the changes and close the dialog.

## 6.10.3 Positioning and adjusting the EMG display windows

The visualization display can be situated either above the slices window as a full screen display, on its own monitor, or as a large display in place of the slices, above the 3D head and Aiming Tool.

- In the **Graph Settings** -tab, check **Dual display** if you want to use two displays (one for NBS and one for EMG).
- To adjust the width of the EMG continuous view and epochs view, click on the vertical bar and drag it to the desired location.

## 6.10.4 Defining the voltage level and time for EMG signals

Refer to Chapters 5.14 “Graph Settings -tab” on page 79 and 5.15 “EMG display” on page 81.

You can adjust the voltage level and time periods for the continuous and epochs EMG views in the **Graph Settings** -tab.

You can use the white cross found on EMG continuous and epochs views (see Figure 85) to help adjusting the signal voltage and time (displayed next to the cross).

- In the continuous EMG view, the time is displayed in relation to the start of the measurement.

- In the EMG epochs view, the time is displayed in relation to the moment the stimulation pulse was given. Before the pulse, the time is negative and after the pulse the time is positive.
- The voltage is displayed in relation to the zero level.

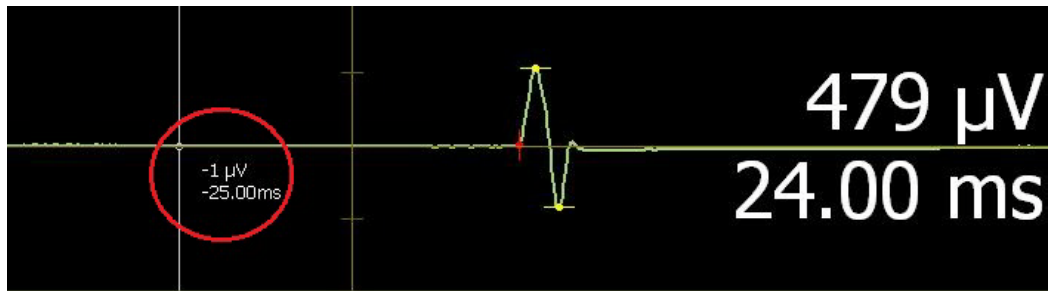


Fig. 85. White cross displaying the time and voltage information on the EMG epochs view

### 6.10.5 Selecting display methods for EMG signals

To limit the display of peaks of an EMG response within the pane allocated to each EMG channel, select the **Clip signal to pane** on the **Graph Settings** -tab. See Figure 87 as opposed to Figure 86.

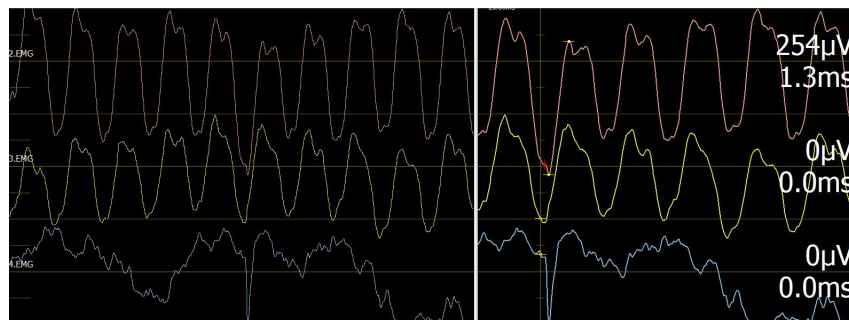


Fig. 86. EMG not clipped to pane and not inverted

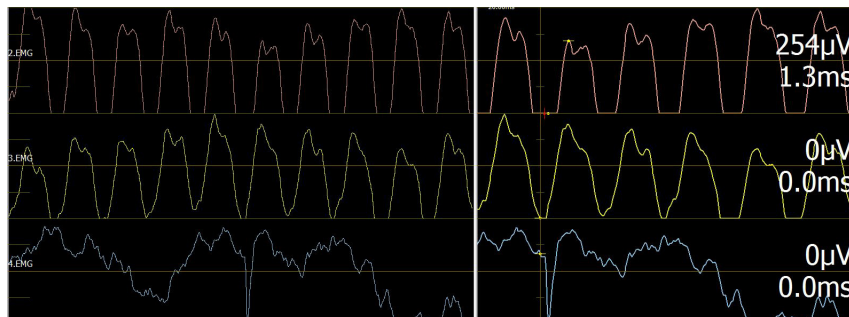


Fig. 87. EMG clipped to pane



To flip the EMG measurement peaks in the EMG display, select **Inverse EMG**. See Figure 88 as opposed to Figure 86.

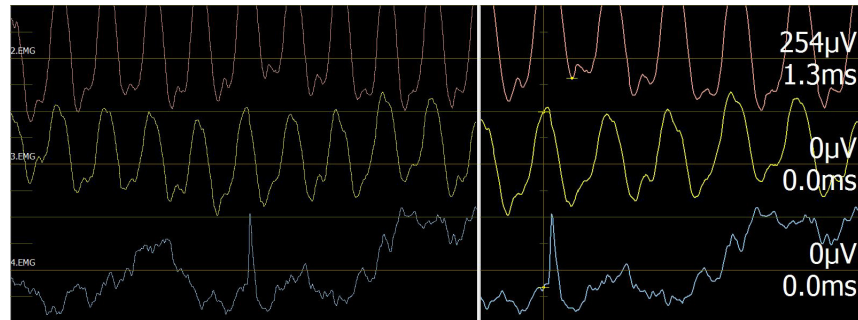


Fig. 88. EMG inverted

### 6.10.6 Stimulating with EMG

Depending on the strength of the EMG response, the stimulus is colored as follows:

- < 50  $\mu\text{V}$  gray
- 50 - <500  $\mu\text{V}$  red
- 500 - <1000  $\mu\text{V}$  yellow
- $\geq$  1000  $\mu\text{V}$  white.

Basic response detection draws three markers on the EMG curve (Figure 89):

- Red marker: The beginning of the response. Latency is the distance from the stimulus (marked with the vertical line) to the beginning of the response. (56.00 ms in Figure 89.)
- Two yellow markers: Peaks of the response. Peak-to-peak is the distance between the two markers. (50  $\mu\text{s}$  in Figure 89.)

The markers are drawn to the zero if the response is not recognized.

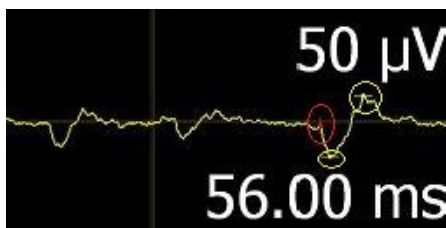


Fig. 89. EMG response markers circled

## 6.10.7 Response Detection during stimulation

Figure 90 displays the EMG view after a stimulation pulse has been delivered. The EMG view shows the selected settings, marked with character “\*”. If the detected response is within the set limits, the markers are drawn to the detected peaks. Otherwise they are drawn to zero.

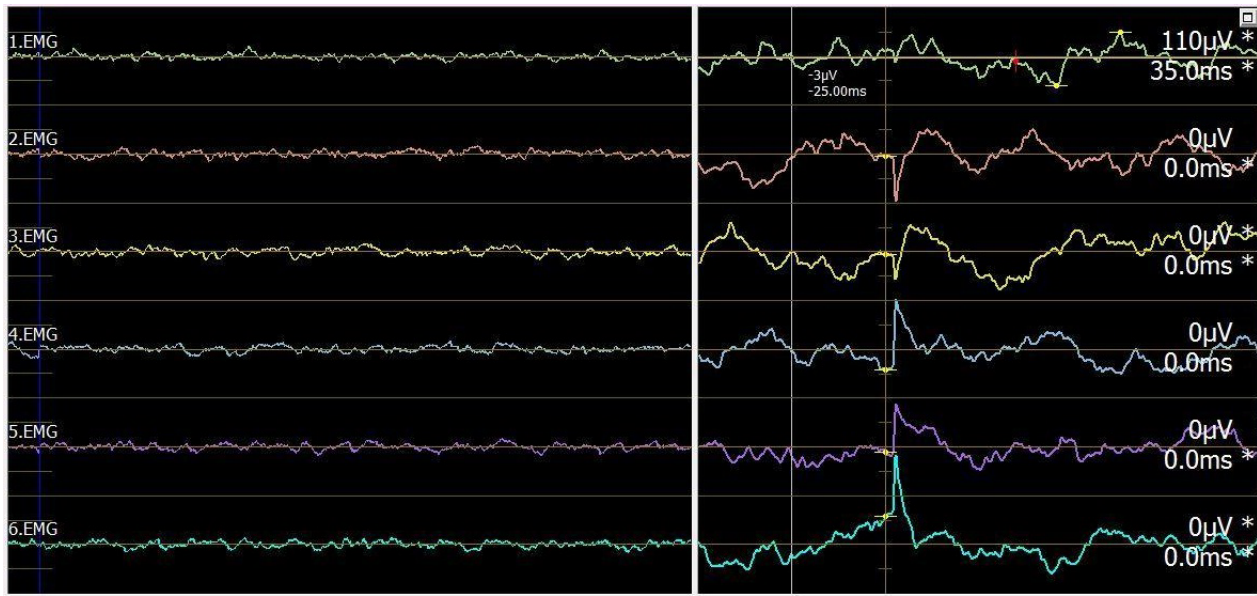


Fig. 90. Used response settings in the EMG epochs display

Table 27 clears which values are in use and what has been the decision in each point in Figure 90.

Table 27 Reading the EMG epoch display

Channel number	Latency window	Amplitude threshold	Decision
1	In use	In use	Is a response
2	In use	Not in use	Not a response
3	In use	In use	Not a response
4	Not in use	Not in use	Not a response
5	In use	Not in use	Not a response
6	In use	In use	Not a response

## 6.10.8 Correcting the EMG response parameters manually

Figure 89 displays the response markers, which can be used to modify the detected peak-to-peak and latency values.

---

### NOTE:

We recommend you to carefully check and verify each detected value.

---

The position of the markers on the EMG epochs view can be changed by clicking and dragging the marker. The numerical values are updated in real time in the Analysis Table (if visible) and the response window.

This can only be done when the signal is not running in the continuous EMG view.

## 6.10.9 Navigating continuous EMG signals

When EMG measurement is on:

1. Click **Hold** in the **EMG**-tab to freeze the signal in the continuous EMG view.
2. To scroll the continuous EMG view, use the **<-- Previous** and **Next -->** buttons in the **EMG** tab.
3. Release the signal.

When EMG measurement is off:

1. Select a stimulus (containing EMG data) from the session tree or Analysis Table.
2. To scroll the continuous EMG view, use the **<-- Previous** and **Next -->** buttons in the **Graph Settings** -tab.

## 6.11 Performing stimulation

---

### NOTE:

The NBS study is limited to the parts of the brain in the first few centimeters below the skull.

The stimulation is stronger in the superficial parts of brain, and weaker in the deeper brain structures.

The maximum available pulse repetition rate depends on the intensity. At high repetition rate the intensity decreases.

When there are two or more persons performing the stimulation (for example, one stimulating and the other monitoring the NBS display), be careful not to use the NBS controls while Nexstim TMS II is delivering pulses. For example, dragging a dialog with a mouse during pulse delivery may slow down the NBS or otherwise cause interference to the stimulation.

It is advisable to test the protocol without a patient before the actual session to make sure that the coil surface temperature stays on acceptable level during the planned stimulation session.

The coil surface temperature continues to rise after the stimulation sequence. As soon as the coil is overheated, the system interrupts the ongoing sequence. You must wait for the coil to cool down to operating temperature before the stimulation can be continued.

If the coil is overheated during an rTMS or Defined series sequence, the sequence is paused. While paused, the coil can be changed to another coil of the same coil type and the sequence can be continued. The coil cannot be changed if the rTMS or Defined series sequence is started. This is indicated by the yellow warning LED in the stimulator above the coil connector.

Magnetic stimulation may heat metal objects.

---

### 6.11.1 Creating and closing stimulation exams

---

#### NOTE:

A stimulation exam may contain several sequences of different types.

---

1. To create a new stimulation exam, click **New exam** in the **Stimulation**-tab.
2. Enter the necessary information in the appearing **Exam information** -dialog and click **OK**.
3. A new exam is now created and set as active in the session tree.
4. After performing stimulation, you can close the exam by clicking the **Close exam** -button. When closing, no more sequences can be added to the exam.

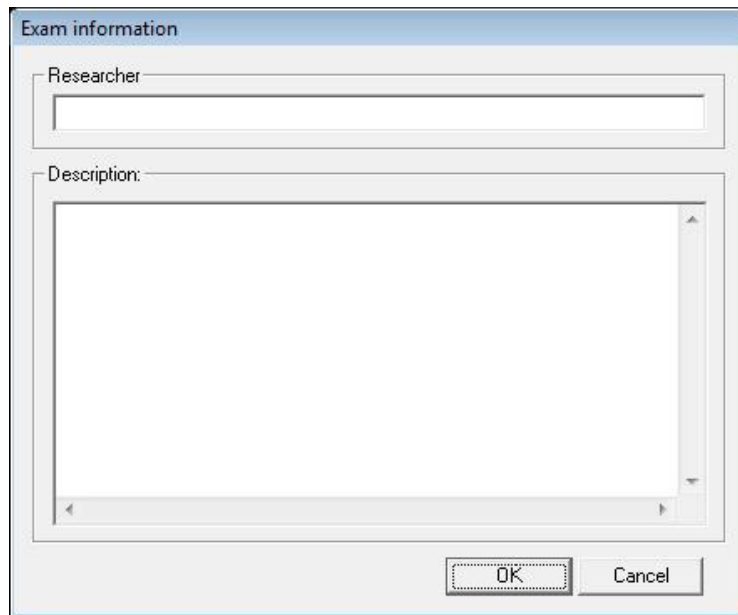


Fig. 91. Exam information -dialog

### 6.11.2 Single-pulse stimulation

1. In the **Stimulation**-tab, select **Single pulse** -tab > **Single pulses** -radio button.
2. Click **New Sequence** to open the **Stimulation in single pulse mode** -dialog (for dialog description, see page 63).

A new single pulse sequence cannot be created if:

- No session is open.
- No exam is open.
- An active sequence is already open.
- “Show ISI and randomize” is selected, interstimulus interval (ISI) is less than 1500, and EMG measurement is started.

You can record as many stimuli as you like in the sequence. The sequence is given a description during closing which is recorded in the session tree with the sequence.

When a new sequence is begun, then all navigated stimuli are set to be invisible.

When a new sequence is started, the stimulator intensity will be the same as it was when the stimulator was last used.

If a new stimulation sequence is created without registration, see Chapter 6.11.5 “Stimulation without navigation” on page 114.

3. Adjust the stimulation intensity using the slider, foot switch, or - and + -buttons. Intensity values can vary between 0 - 100 %. The value(s) are updated in both the slider and the dialog.

4. If you want to use location controlled stimulation, select the check box.
5. Deliver stimuli as described in Chapter “Stimulation in single pulse mode -dialog” on page 63.  
The stimulus is visualized as a spot at the maximum point in the electrical field on the peeled surface which also has the maximum direction “little hook”.
6. To close the stimulation sequence, click **Stop sequence**.
7. The **Sequence description** -dialog opens. Give a description of the sequence and click **OK**. When closing, no more stimuli can be added to the sequence.

### 6.11.3 Defined series stimulation

Defined series are predefined stimulation programs, that is, series of single pulses. The interstimulus interval (ISI) and stimulus intensities may vary from stimulus to stimulus.

1. In the **Single pulse** -tab, select the **Defined series** -radio button and click the [...] -button to open the **Select Defined Series** -dialog (see Chapter “Select Defined Series -dialog” on page 64).
2. In the **Select Defined Series** -dialog, select a Defined series category from the pull-down menu. Possible selections are “Most recent” and “Nexstim”.
3. Select a Defined series sequence file from the pull-down menu and click **OK** to confirm the selection. You are returned to the **Single pulse** -tab.
4. Click **New Sequence** to open the **Defined Series Run** -dialog. (See Chapter “Defined Series Run -dialog” on page 65.)

If a new stimulation sequence is created without registration, see Chapter 6.11.5 “Stimulation without navigation” on page 114).

5. Before starting stimulation, you can change the Base-intensity by using:
  - the Base-slider using the mouse
  - the foot switch, when the **Intensity Control (foot pedal)** -check box is checked.

When the slider is moved, the preview diagram is updated:

- Red dashed line in the preview diagram moves according to the slider.
  - Intensities move with the red dashed line.
  - Base- and the Next pulse-intensities are updated.
6. Click **Start** or push the left foot switch once to start stimulation. A new sequence is created in the session tree. The following fields are updated real-time:
    - “Pulses remaining”
    - “Time remaining”, and
    - “Preview diagram” (the elapsed time is colored green).

When stimulation has started, new Defined series sequence -structure is created and marked active in the session tree. “Defined series completed” is NO until the sequence is completed.

As the stimulation progresses, the stimuli are added to the session tree. Stimulus-items are added under the Stimuli during the sequence.

7. If registration has been performed, then stimulation is automatically paused if:

- Head tracker is not visible to the camera
- Stimulation coil is not visible to the camera.

If **Location controlled stimulation** -check box is checked, stimulation is also paused when the Aiming Tool is not in position.

8. Defined series stimulation stops when the sequence is completed. You may also stop the stimulation sequence by clicking the **Stop**-button.

9. After delivering the sequences, you can close the dialog by clicking the **Close** -button.

Clicking the **Start** -button starts another sequence, which is created under the active Stimulation Exam. If you want to create sequences under a different Stimulation Exam, the **Run Defined series** -dialog must be closed first.

## 6.11.4 Repetitive stimulation

---

### NOTE:

Repetitive stimulation is for use with NexSpeech only.

---

1. Select the **Repetitive**-tab.

By default, the name and description of the last selected rTMS sequence, as well as the %MT, Number of pulses, Frequency and Duration are displayed under the **Select/Edit Sequence** -button.

2. If you want to change the sequence, click the **Select/Edit Sequence** -button to open the **rTMS Sequence Editor** -dialog, or continue directly to Step 9. (For dialog description, see page 69.)

3. In the **rTMS Sequence Editor** -dialog, select a sequence category from the pull-down menu. Possible selections are “Most Recent”, “Nexstim”, or “User”.

4. Select a rTMS sequence file from the pull-down menu.

5. If you want to edit the values, enter the appropriate values.

6. Click **Save** to save sequence. Enter the file name and description in the appearing dialog and click **OK**.

7. Click **OK** in the **rTMS Sequence Editor** -dialog. You are returned to the **Repetitive**-tab, which now shows the updated values.

8. Enter the appropriate Intensity or MT values.

9. Click **New rTMS Sequence**.

If a new rTMS sequence is created without registration, you are asked if you want to continue without registration (navigation). If you continue without registration, the coil location is not recorded nor controlled. Coil location information or electric field values are not shown.

10. The **rTMS Run** -dialog opens (see page 72).
11. Click **Start** or use the left pedal on the foot switch to start stimulation.
12. Repetitive stimulation stops when the sequence is completed. You may also stop the rTMS sequence by clicking the **Stop**-button.
13. After delivering the sequences, you can close the dialog by clicking the **Close** -button.

### 6.11.5 Stimulation without navigation

Stimulation is possible also without navigation. This is done by starting a new stimulus sequence without performing the registration. If you continue without registration, the stimuli are stored in the session, but the coil location information or electric field values are not recorded nor controlled.

Message *“Registration not performed. Do you want to continue?”* is displayed when you are about to stimulate without using navigation.

Click **Yes** to continue stimulation without using navigation, or **No** to perform registration before restarting.

### 6.11.6 Navigated stimulation

When the registration is performed and the corresponding indicator LED is green (see Chapter 5.2 “Navigation and display controls” on page 46), the navigation is in use. The stimulation cannot be delivered if the coil and the head tracker are not visible to the NBS tracking unit.

### 6.11.7 Setting the stimulation target

Stimulation targets are markers, which can be placed on the brain locations to help the stimulation. In the Nexstim NBS, the coordinates for the stimulation targets can be pinpointed with crosshair or entered with coordinates.

---

**NOTE:**

A peeling depth of 20 mm (0.8 in) provides the most accurate results during stimulation. It is also advised to set stimulation targets at this depth.

---

1. Select **Add Stimulation target...** in the **Navigation**-tab to open the **Setting Stimulation target** -dialog (see page 56).
2. Set the coordinate system used in the stimulation target setting.



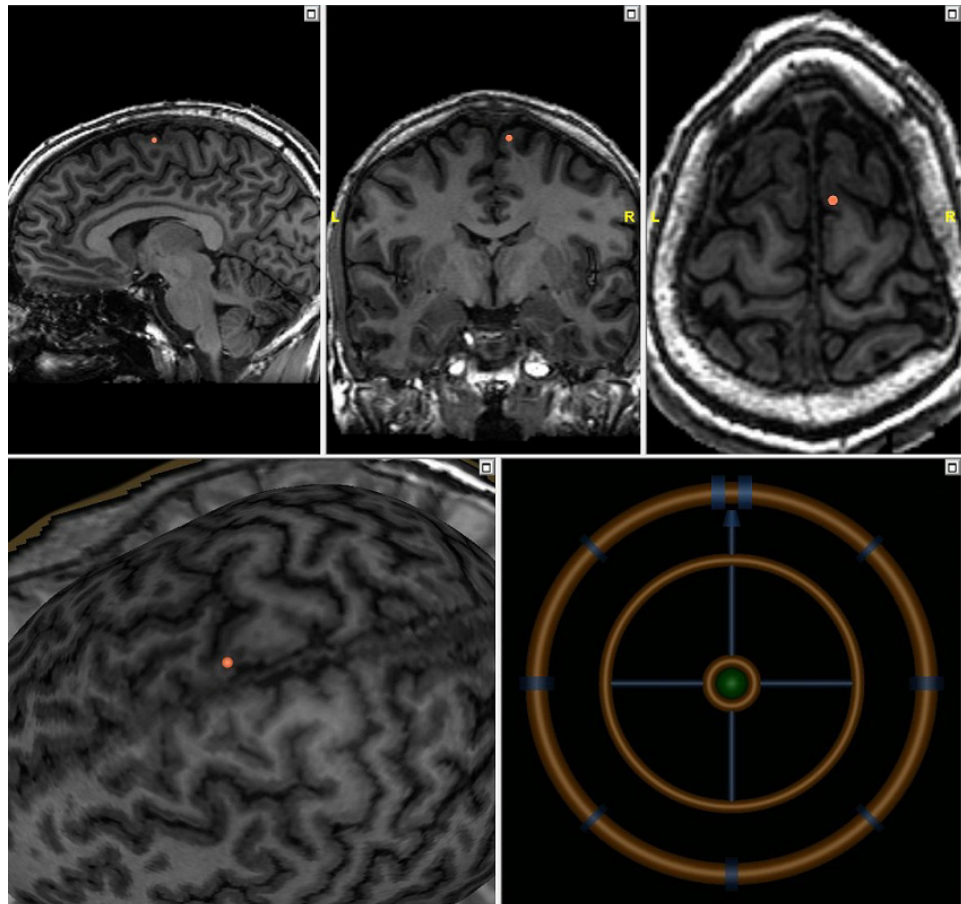
3. Add the coordinate values for the target in the boxes and select **Update MRI views** to move the crosshair to the given coordinates on the NBS display and verify that the target location is correct.  
OR  
Select the target location with the crosshair from MRI slices or 3D brain surface.
4. Enter a description for the stimulation target.
5. Select **OK** to save the stimulation target and to exit the dialog. If you select **Cancel**, the dialog is closed and the data is not saved.
6. Check that the saved stimulation target is in the session tree under **Stimulation Targets**.

---

**NOTE:**

After setting a stimulation target, check to make sure that there are no dips or grooves in the peeled 3D head surface anywhere near the target.

---



**Fig. 92.** Stimulation target displayed on the MR images and 3D head

## 6.11.8 Stimulating to a stimulation target

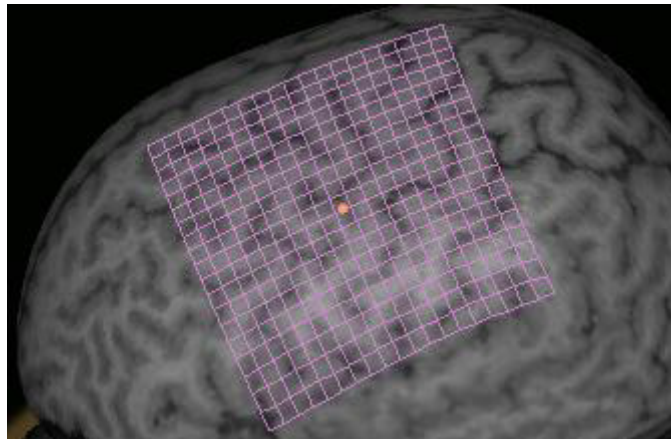
---

**NOTE:**

Registration must be performed before stimulating to a stimulation target.

---

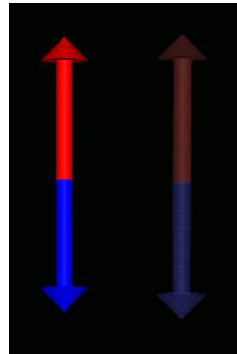
1. Highlight the stimulation target point in the session tree.
2. Right-click the target point and select **Set as active stimulation target** from the pop-up menu.
  - You can set one stimulation target active at a time. A previously active target will be inactivated.
  - The color of the “hat” of the active stimulation target differs from that of the other targets in the 3D window and the MR slice windows.
  - If a particular stimulation target is activated, the 3D window information shows the distance between the EF maximum and the active stimulation target. Also the electric field value is shown in the MR target. (See Chapter 5.8 “Info panel” on page 54.)
  - When activating a target, the 3D head is peeled automatically to the depth of the active target.
  - If the **Show target grid** -option in the **Settings**-tab (see Chapter 5.13 on page 76) has been selected, the targeting grid will appear on the 3D head display around the active stimulation target.



**Fig. 93.** Stimulation target and target grid

3. Turn the 3D head to get the target point clearly visible. Rotate and zoom if needed.
4. Open a stimulation dialog.
5. Check that the coil and electric field are properly displayed on the screen.
6. Place the coil on the stimulation target point by guiding the maximum stimulating field to the target point. You can use the targeting grid to assist in stimulating around the stimulation point.

Check that the coil is placed optimally. The directional arrow is bright when the coil is in optimal position and dim when not. The stronger direction of the stimulation is displayed as a red arrow, and the weaker direction as a blue arrow (Figure 94).



**Fig. 94.** Coil placement arrows, indicating direction of the stimulus pulse

---

**NOTE:**

If the directional arrow never turns bright through coil positioning, you will have to re-register.

---

7. Perform stimulation, using the grid to help the targeting. As an example, see Figure 132, “Isolating the response area (target grid visible),” on page 167.
8. After the stimulation, select **Disable active stimulation target** from the session tree.

## 6.11.9 Repeating the stimulus

Any navigated stimulus can be set as repeated stimulus (that is, active). Only one stimulus at a time can be set as repeated. The operation deactivates any possible repeated stimulus. The Aiming Tool is activated with the stimulus that is to be repeated.

The repeated stimulus’ “hat” in the 3D window is colored differently to other stimuli.

1. Highlight the navigated stimulus in the session tree.
2. Right-click the stimulus and select **Repeat stimulus** or **Repeat rTMS Reference Stimulus** in the pop-up menu.  
Use the Aiming Tool to position the coil to repeat the selected stimulus. (In addition, see Chapter 6.11.4 “Repetitive stimulation” on page 113).
3. When you are ready, right-click the stimulus in the session tree and select **Finish repeating Stimulus** or **Finish repeating rTMS Reference Stimulus**. The Aiming Tool is now deactivated.

In Defined series stimulation, the first stimulus is automatically set as repeated.

### 6.11.10 Location controlled stimulation

Location controlled stimulation is an option in single pulse stimulation, Defined series stimulation, and MT determination, and is used for repeating the conditions of any navigated stimulus. Location control means that stimulation is allowed only if the coil position, rotation, and orientation are identical with the conditions of the stimulus to be repeated.

Location controlled stimulation can only be switched on if registration is complete and the active (repeated) stimulus is set. Active stimulus can be a stimulus from single pulse stimulus sequence, an rTMS reference stimulus, or from stimuli contained in MT exams.

Selecting the “Location controlled stimulation” check box prevents the stimulation when the Aiming Tool is incorrectly positioned. If the check box is left unchecked, the Aiming Tool can be used to assist the positioning of the coil.

## 6.12 Determining Motor Threshold

Motor Threshold (MT) is determined as the stimulator intensity using which a response is elicited from the target muscle in 50% of trials. A response is usually determined as EMG response over 50  $\mu$ V.

MT is muscle- and patient-related. It might vary due to time of the day, patient activity level, or even hormonal activity. Therefore, it is an estimated value.

---

**NOTE:**

Motor Threshold determination cannot be performed without Nexstim EMG.

Analysis Table may contain also analysis stimuli (in Analysis Exams), which cannot be used in MT determination. In such a case, **Motor Threshold determination** is not an option.

---

1. Before you can determine MT, the following prerequisites have to be fulfilled:
  - You have performed registration.
  - EMG is connected and EMG measurement has been started.
  - At least one EMG channel is in use to follow the target muscle.
  - TMS II is on and the status is “Ready”.
  - There is a stimulus representing the target muscle. This stimulus is referred as the “starting stimulus”.
  - There are no active exams.
2. The starting stimulus shows the coil location and orientation, and the aim is to repeat these. You have the following selection options to start the MT:
  - a) In the session tree, select the starting stimulus. Right-click and select **Motor Threshold determination** from the pop-up menu (Figure 95).

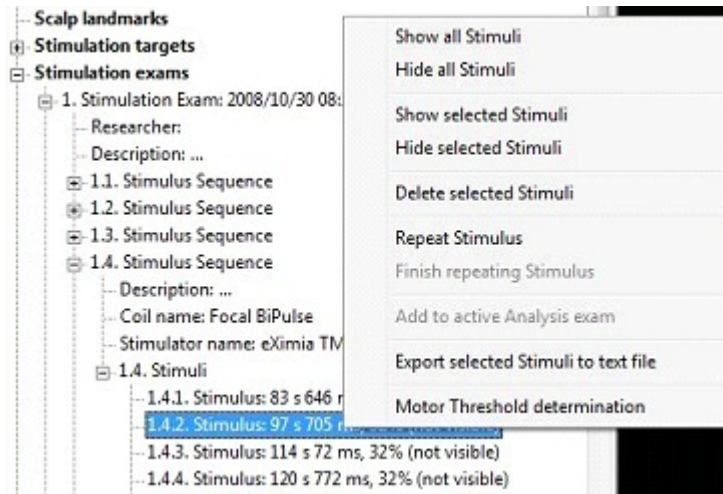


Fig. 95. Selecting Motor Threshold determination in the session tree

b) In the Analysis Table containing stimuli, right-click the starting stimulus and select **Motor Threshold determination** from the pop-up menu (Figure 96).

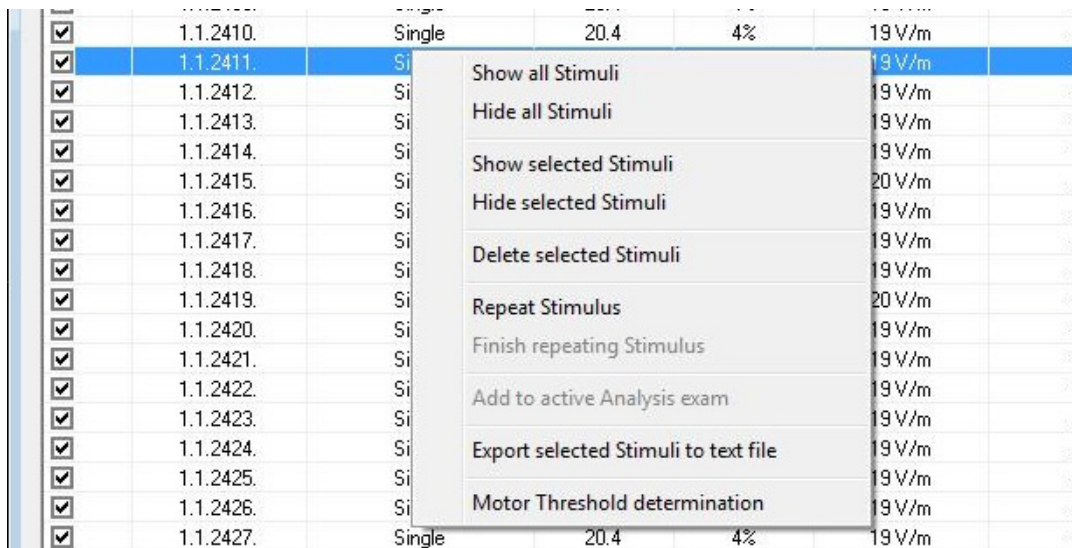


Fig. 96. Selecting Motor Threshold determination in the Analysis Table

3. In the appearing **Motor Threshold** starting -dialog (Figure 97), enter the process parameters (described in Table 28).

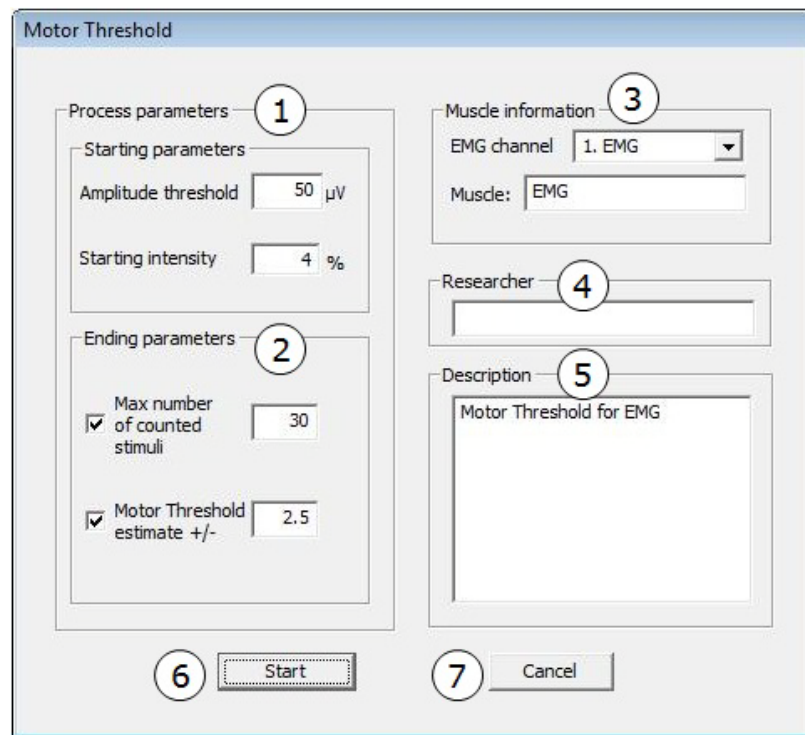


Fig. 97. Motor Threshold starting -dialog

Table 28 Motor Threshold starting -dialog parameters and controls

1	Starting parameters	<ul style="list-style-type: none"> <li>• <b>Amplitude threshold:</b> Reference value for the peak-to-peak value of the EMG response.</li> <li>• <b>Starting intensity:</b> Intensity using which the first pulse is given.</li> </ul>
2	Ending parameters	<p>Ending parameters are the criteria for the MT determination process. At least one parameter must be chosen. If both are selected, the determination process ends when either one is fulfilled.</p> <ul style="list-style-type: none"> <li>• <b>Max number of counted stimuli:</b> When selected, the MT determination is finished when the number of stimuli used in the estimation reaches the value entered in this field. Allowed range is 1-99.</li> <li>• <b>Motor Threshold estimate +/-:</b> When selected, the MT determination is finished when both upper and lower limit are below the value set here. Unit is the stimulator intensity. Allowed range is 0.1 - 50. For example, if using the default value at 2.5, the process would end when the values are: estimate 45, upper 47.4, lower 42.6.</li> </ul>
3	Muscle information	<ul style="list-style-type: none"> <li>• <b>EMG channel:</b> Select the EMG channel from the pull-down menu containing all EMG channels in use.</li> <li>• <b>Muscle:</b> Enter the name of the muscle, for which MT is determined.</li> </ul>
4	Researcher	Enter the name of the researcher. This field can also be left empty.
5	Description	Give a description of the MT exam. This field can also be left empty.
6	<b>Start</b>	Opens the <b>Motor Threshold</b> running -dialog (Figure 98) and activates the Aiming tool. Motor Threshold Exam is created into the session tree.
7	<b>Cancel</b>	Cancels the MT determination process. Nothing will be created in the session tree.

4. Click **Start** to open the **Motor Threshold** running -dialog (see Figure 98 and Table 29).

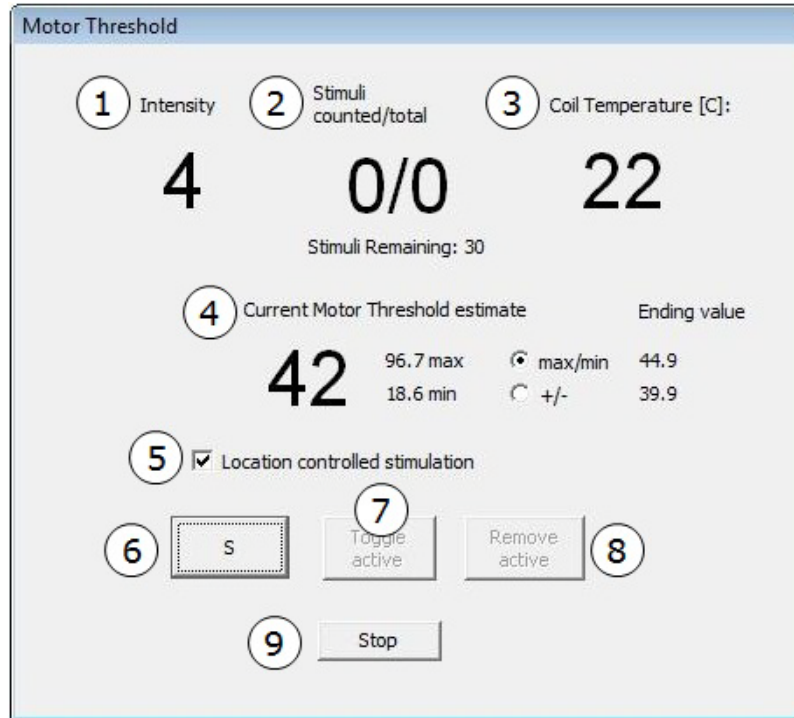


Fig. 98. Motor Threshold running -dialog

Table 29 Motor Threshold running -dialog controls

1	Intensity	Number tells the intensity for the next stimulus.
2	Stimuli counted/total	<ul style="list-style-type: none"> <li>• <b>Counted:</b> Number of stimuli used in the estimation</li> <li>• <b>Total:</b> Total number of stimuli delivered.</li> <li>• <b>Stimuli remaining:</b> If the Ending parameter <b>Max number of counted stimuli</b> is in use, this shows the number of remaining stimuli.</li> </ul>
3	Coil Temperature	Temperature of the coil (in degrees Celsius)
4	Current motor threshold estimate	<p>Large number is the current MT estimate and two smaller numbers are the upper and lower error bounds. The viewing mode can be selected:</p> <ul style="list-style-type: none"> <li>• <b>max/min</b> shows the errors in the stimulator intensity scale.</li> <li>• <b>+/-</b> shows the errors related to the estimate.</li> </ul> <p>If the ending value <b>Motor Threshold estimate +/-</b> is in use, this shows the ending values with which the process will end.</p>
5	Location controlled stimulation	If selected, prevents the stimulator from delivering a pulse unless the Aiming Tool is green.
6	<b>S</b>	Delivers a stimulus. You can also use the left pedal on the foot switch to deliver a stimulus.



Table 29 Motor Threshold running -dialog controls

7	<b>Toggle active</b>	Button shall be enabled only when there is an active stimulus in the session tree. Changes the classification of the active stimulus from over to under and vice versa. Refers to the Active stimulus in the tree. You can also use the middle pedal on the foot switch to toggle.
8	<b>Remove active</b>	Remove the stimulus from the estimation process. Refers to the Active stimulus in the tree. You can also use the right pedal on the foot switch to remove a stimulus.
9	<b>Stop</b>	You may stop the MT determination process at any time. A user-stopped process is marked in the session tree with a postfix S.

5. Click **S** in the **Motor Threshold** running -dialog or the left pedal on the foot switch to stimulate. NBS will classify the EMG response.

Figure 99 shows the display after delivering the stimulus.

- If you disagree with the classification, but the response is OK, toggling can be used to change the classification.
- If the response cannot be accepted (the patient has moved, or muscle tension can be seen), the stimulus (response) can be removed from the estimation process.
- If everything is OK, deliver another stimulus.



Fig. 99. The selected EMG channel displayed in the EMG view



6. The stimulation continues until:
  - a) the selected ending parameters are reached
  - b) you click **Stop** to stop the process.
7. When the MT determination process ends, the **Motor Threshold** result -dialog is displayed (see Figure 100).

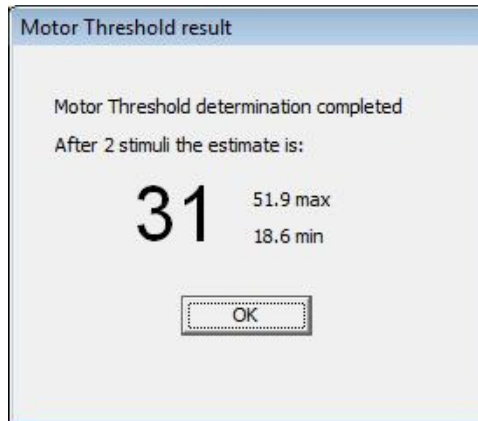


Fig. 100. Motor Threshold result -dialog

- a) If you click **Stop** to stop the MT determination process, the following dialog is displayed (Figure 101). Clicking **No** removes all information of the current MT process.

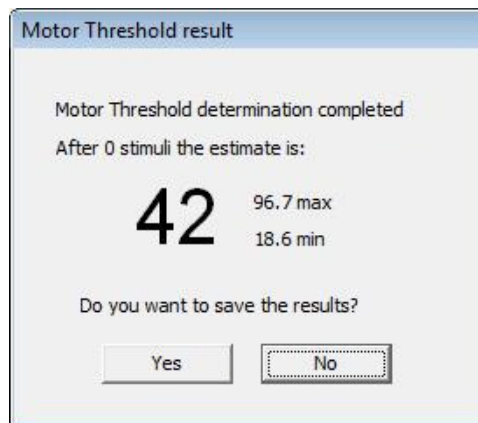
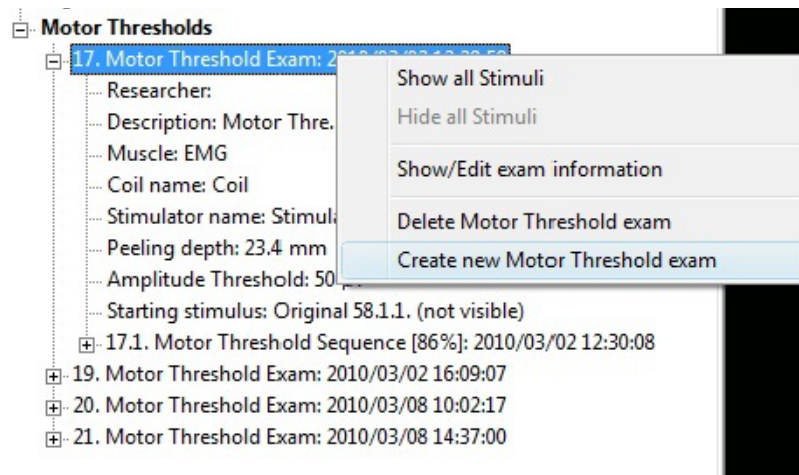


Fig. 101. MT determination stopped by the user

8. Click **OK/ Yes** to save the MT sequence.
9. The **Edit Motor Threshold Sequence description** -dialog opens, where you fill in the Researcher and Description fields.
10. Click **OK** to save the information. Click **Cancel** if you do not want to update the Researcher/Description information.

### 6.12.1 Starting MT determination from an MT exam

To repeat a previous MT determination, the MT determination process may also be started from the session tree pop-up menu of a Motor Threshold exam. This creates a new MT sequence under that exam.



**Fig. 102.** Starting a MT determination from an MT exam

The process is the same as described in Chapter 6.12, except for two issues:

- Amplitude threshold cannot be changed.
- Muscle cannot be changed.

This is because otherwise the two sequences are not comparable.

Additionally, if you try to create another sequence under an exam, using a different setup (that is, coil), a choice for creating a new exam is given. Coils will have an effect on the MT value, and thus two MTs achieved from using two different coils will not be comparable.

If the active setup differs, the user is notified with the message: *“Active setup differs from previously used. A new Motor Threshold Exam will be created. Do you want to continue?”*. After selecting **Yes**, the prerequisites are checked.

## 6.13 Using the session tree

Refer to Chapter 5.3 on page 48 for a description of the session tree.

To access the context-specific pop-up menus, right-click the mouse over an item in the session tree. The operations visible in the pop-up menu depend on the item over which the mouse is clicked.

### 6.13.1 Expanding and collapsing contents in the session tree

The tree root heading displays a plus sign (+) to indicate that there are subheadings beneath the root heading. The tree root displays a minus sign (-) when the tree has been expanded or when there are no subheadings to the root heading.

- To expand (to display the subheadings under the tree root heading), click the plus sign.
- To collapse (not to display the subheadings under the tree root heading), click the minus sign.

### 6.13.2 Selecting items in the session tree

One or several objects can be selected at a time. The selection is made by clicking a tree item with the left mouse button. You can use the SHIFT and CTRL keys to select several objects at once.

- To select successive multiple items, hold the SHIFT key and select the first and last items. All items inbetween will also be selected.
- To select individual items, hold the CTRL key and select the items by clicking on them.

If a navigated stimulus is selected from the tree and the head is in peeling view, then the head is peeled to the depth of that stimulus. The electric field of the selected stimulus is colored on the brain surface. Info panel shows more information on the electric field values.

Stimuli delivered without navigation (the location is not specified) are not shown in the 3D window.

### 6.13.3 Pop-up menus

When the objects are selected in the session tree, the operation to be performed can be executed from a pop-up menu. It is opened by clicking the tree item with the right mouse button.

The operations visible in the pop-up menu depend on the selected object (over which the mouse is placed when the button is clicked), that is, where the menu is opened. Some operations are executed for all selected objects of that type.

This chapter describes the pop-up menus for different session tree items.

## Pop-up menu for “General” root heading

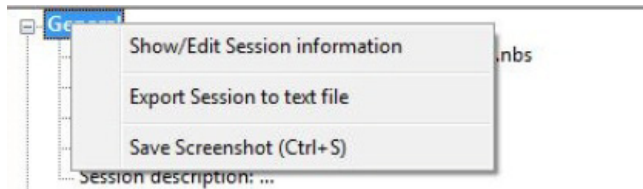


Fig. 103. Pop-up menu for session tree root heading General

Table 30 Session tree operations for root heading General

Operation	Description
Show/Edit Session information	You can view or change the name of the researcher for the session, the organization, and session description.
Export Session to text file	See Chapter 6.14 “Exporting session data”.
Save Screenshot (Ctrl + S)	See Chapter 6.14.3 “Saving screenshots”.

## Pop-up menu for “MRI landmarks” and “Scalp landmarks” root headings

You can set the visibility of both MRI and scalp landmarks through the “show/hide” -commands. The operation affects both the MR slice images and the 3D window.



Fig. 104. Pop-up menu for MRI landmarks (on the left) and Scalp landmarks (on the right)

## Pop-up menu for “Stimulation targets” and “Stimulation target”

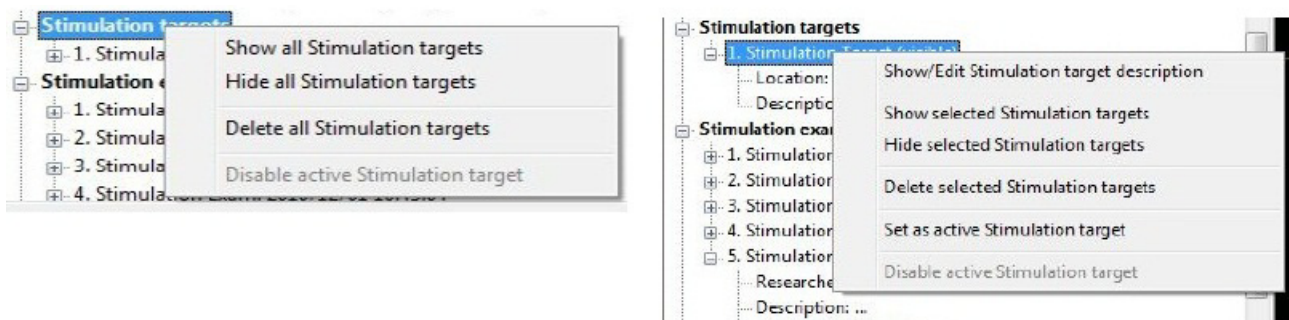


Fig. 105. Pop-up menu for Stimulation targets (on the left) and for a specific Stimulation target (on the right)

Table 31 Session tree operations for Stimulation targets

Operation	Description
Show/Hide all/selected Stimulation targets	You can control the visibility for all stimulation targets or a specific target.
Show/Edit Stimulation target description	For every stimulation target, you can give a description that will be shown in the tree structure.
Delete all/selected Stimulation targets	You can delete stimulation targets at once or individually.
Set as active Stimulation target Disable active Stimulation target	See Chapter 6.11.7 “Setting the stimulation target”.

### Pop-up menus for items under “Stimulation exams”

The following figures display the session tree operations for Stimulation exams and its sub-components. The session tree operations are explained in Table 32 on page 130.

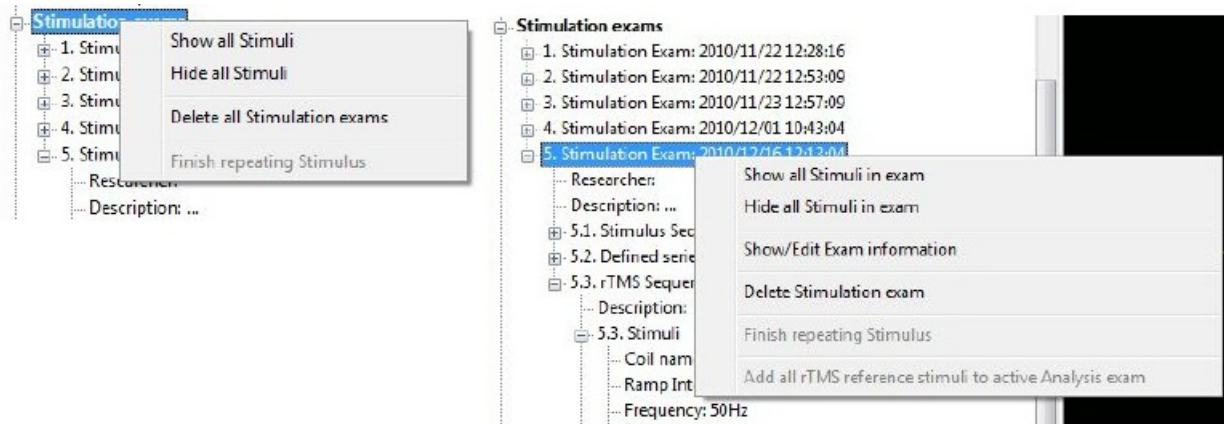
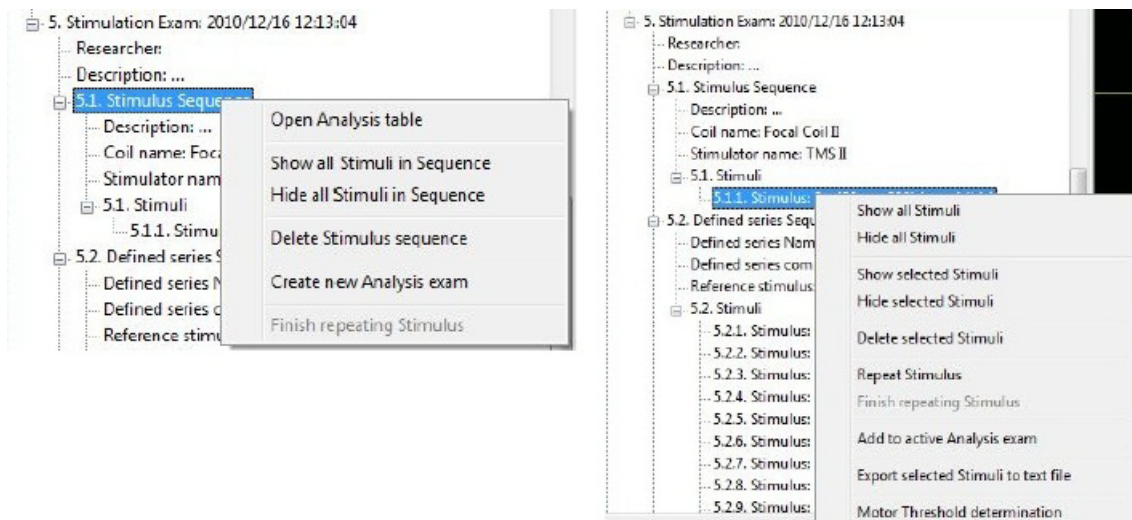


Fig. 106. Pop-up menu for Stimulation exams (on the left) and for a specific Stimulation Exam (on the right)



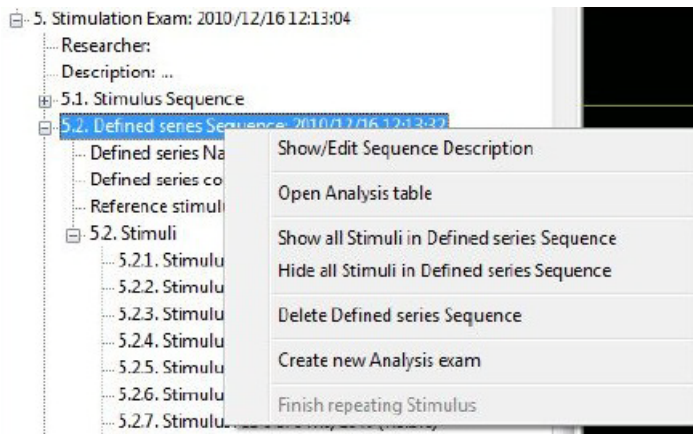
**Fig. 107.** Pop-up menu for a Stimulus Sequence in a Stimulation Exam (on the left) and for a specific Stimulus in a Stimulation Exam (on the right)

---

**NOTE:**

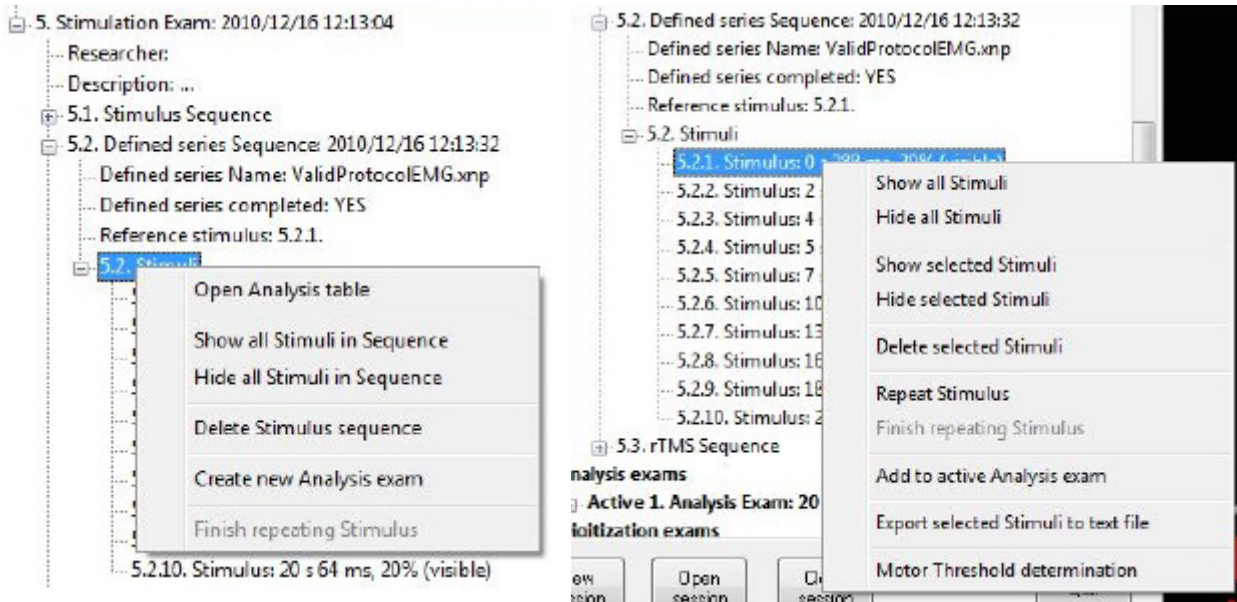
The session tree operations for “Stimuli” item are identical to “Stimulus Sequence” item.

---

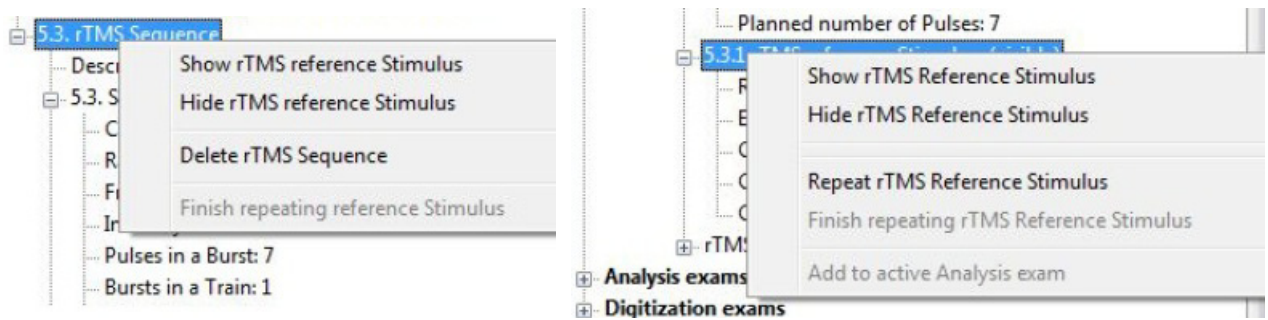


**Fig. 108.** Pop-up menu for a Defined series Sequence





Pop-up menu for Stimuli (on the left) and for a specific Stimulus (on the right) in a Defined series Sequence



**Fig. 109.** Pop-up menu for rTMS Sequence (on the left) and for a rTMS Reference Stimulus (on the right) in a Stimulation Exam

Table 32 Session tree operations for Stimulation Exams and its sub-components

Operation	Description
<b>Show/Hide all/selected Stimuli</b> <b>Show/Hide all Stimuli in exam/Sequence/Defined series Sequence</b> <b>Show/Hide rTMS reference Stimulus</b>	You can control the visibility of stimuli. Non-navigated stimuli are not shown in the 3D window.
<b>Delete Stimulation exam</b> <b>Delete all Stimulation exams</b>	<p>All stimulation exams can be deleted at once or individually. Deleting cannot be done during stimulation or digitization.</p> <p>If the exam to be deleted contains an active stimulus (repeated stimulus), the Aiming Tool is deactivated by the deletion.</p>
<b>Delete Stimulus sequence</b> <b>Delete Defined series Sequence</b> <b>Delete rTMS Sequence</b>	<p>You can delete the selected sequence. Deleting cannot be done during stimulation or digitization.</p> <p>If the sequence to be deleted contains an active stimulus (repeated stimulus), the Aiming Tool is deactivated by the deletion.</p>
<b>Delete selected stimuli</b>	You can delete part of a group of stimuli from a sequence. If an active stimulus (repeated stimulus) is deleted, the Aiming Tool is deactivated.
<b>Repeat/Finish repeating Stimulus/rTMS Reference Stimulus</b>	See Chapter 6.11.9 “Repeating the stimulus”.
<b>Show/Edit Exam information</b>	You can edit the exam information.
<b>Create new Analysis exam</b>	See Chapter 6.15 “Using analysis exams” on page 140.
<b>Add all rTMS reference stimuli to active Analysis exam</b> <b>Add to active Analysis exam</b>	You can select one or several stimuli from the session tree to be added to an active analysis exam.
<b>Open Analysis table</b>	See Chapter 6.15.4 “Opening the Analysis Table” on page 141.
<b>Export selected Stimuli to text file</b>	See Chapter 6.14 “Exporting session data”.
<b>Motor Threshold determination</b>	See Chapter 6.12 “Determining Motor Threshold” on page 118.
<b>Show/Edit Sequence Description</b>	See Chapter “Defined series Description -dialog” on page 67.



### Pop-up menus for items under “Analysis Exams”

The following figures display the session tree operations for Analysis exams. The session tree operations are explained in Table 32 on page 130.

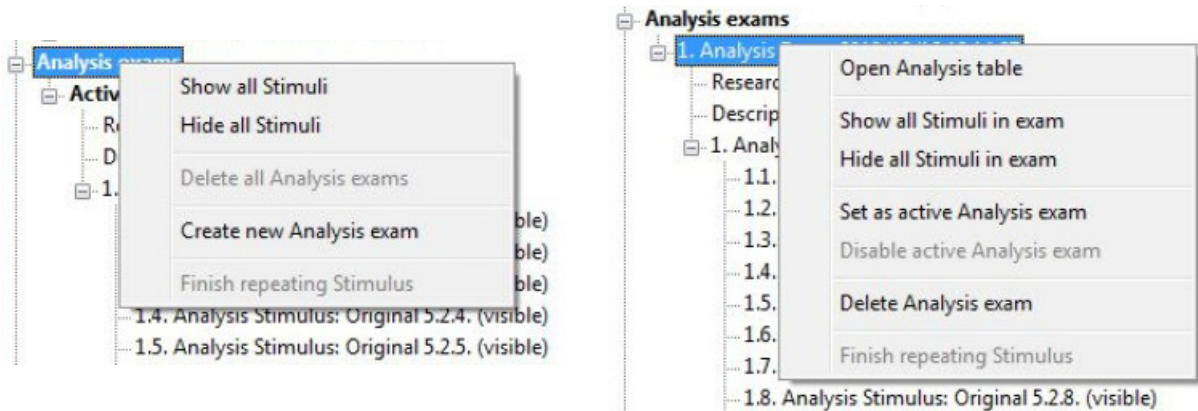


Fig. 110. Pop-up menu for Analysis Exams (on the left) and an Analysis Exam (on the right)

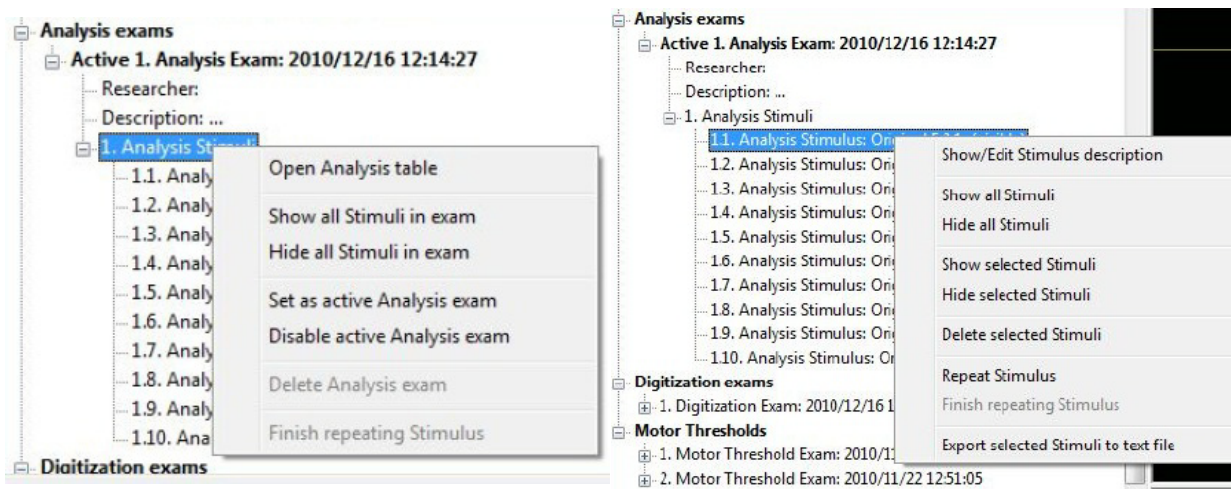


Fig. 111. Pop-up menu for Analysis Stimuli (on the left) and for an Analysis Stimulus (on the right) in an Analysis Exam

Table 33 Session tree operations for Analysis Exams (and Analysis Stimuli)

Operation	Description
Show/Hide all/selected Stimuli	You can control the visibility of stimuli. Non-navigated stimuli are not shown in the 3D window.
Show/Hide all Stimuli in exam	
Create new Analysis exam	See Chapter 6.15 “Using analysis exams” on page 140.

Table 33 Session tree operations for Analysis Exams (and Analysis Stimuli)

Operation	Description
<b>Set as / Disable active Analysis exam</b>	One analysis exam at a time can be active, that is, when an exam is activated, the previously activated exam is deactivated.
<b>Delete selected Stimuli</b>	A selected group of analysis stimuli can be deleted at once. Before deletion, you are asked to confirm the operation. Deleting cannot be done during stimulation or digitization. If an active stimulus is deleted (repeated stimulus), the Aiming Tool is deactivated.
<b>Delete all Analysis exams</b> <b>Delete Analysis exam</b>	All analysis exams can be deleted at once or individually. Deleting cannot be done during stimulation or digitization. If an active stimulus is deleted (repeated stimulus), the Aiming Tool is deactivated.
<b>Repeat / Finish repeating Stimulus</b>	See Chapter 6.11.9 “Repeating the stimulus”.
<b>Open Analysis table</b>	See Chapter 6.15.4 “Opening the Analysis Table” on page 141.
<b>Show/Edit Stimulus description</b>	Each analysis stimulus has its own description in text form. The description is opened in its own dialogue where it can be updated.
<b>Export selected Stimuli to text file</b>	See Chapter 6.14 “Exporting session data”.

### Pop-up menus for items under “Digitization Exams” root heading

The following figures display the session tree operations for Digitization Exams and Digitization Points. The session tree operations are explained in Table 34.

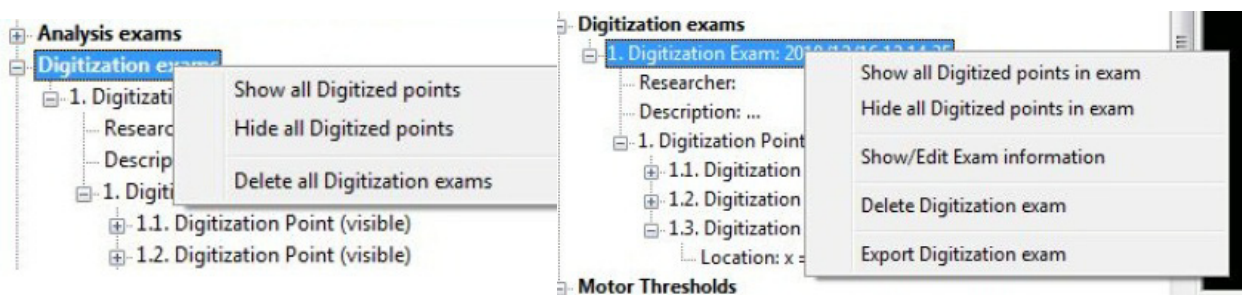


Fig. 112. Pop-up menu for Digitization Exams (on the left) and for a specific Digitization exam (on the right)

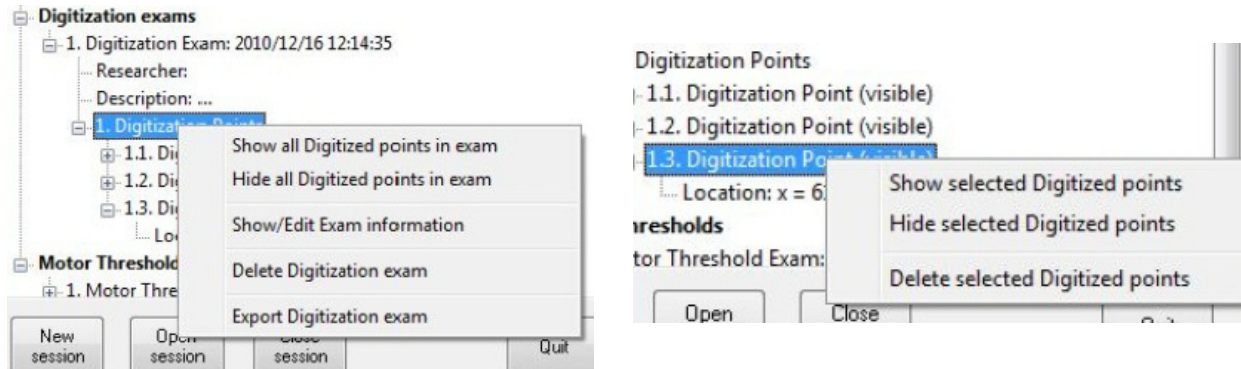


Fig. 113. Pop-up menu for Digitization Points (on the left) and for a specific Digitization Point (on the right) in a Digitization Exam

Table 34 Session tree operations for Digitization Exams (and Digitization Points)

Operation	Description
<b>Show/Hide all/selected Digitized points</b> <b>Show/Hide all Digitized points in exam</b>	You can set a selected group of points to be visible or invisible in the 3D window.
<b>Delete all Digitization exams</b> <b>Delete Digitization exam</b>	You can delete either one or all digitization exams from the session. Deleting cannot be done during stimulation or digitization.
<b>Delete selected Digitized points</b>	You can delete a selected group of points. Deleting cannot be done during stimulation or digitization.
<b>Export Digitization exam</b>	See Chapter 6.14.2 “Exporting digitization data to text file”.
<b>Show/Edit Exam information</b>	You can give a description for every digitization exam.

## Pop-up menus for items under “Motor Thresholds” root heading

The following figures display the session tree operations for Motor Thresholds and its sub-components. The session tree operations are explained in Table 35.

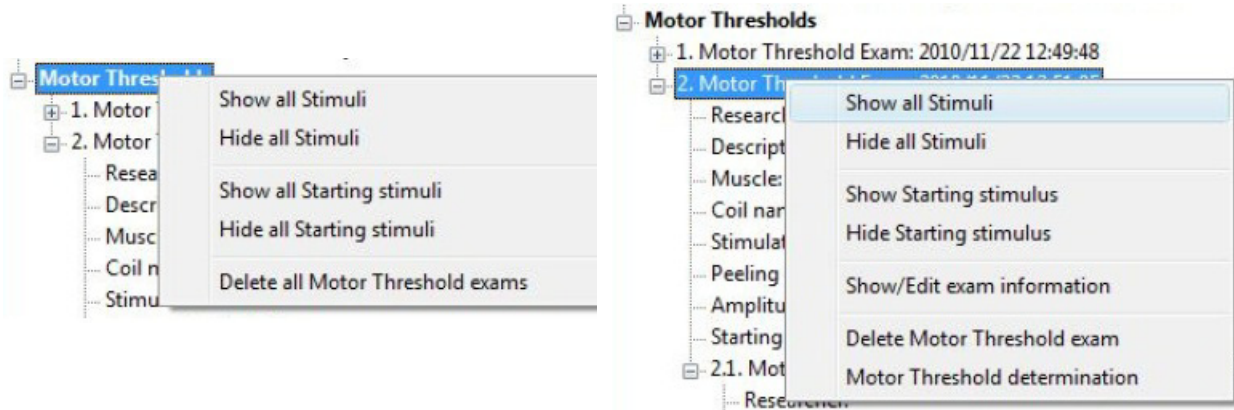


Fig. 114. Pop-up menu for Motor Thresholds (on the left) and a Motor Threshold Exam (on the right)

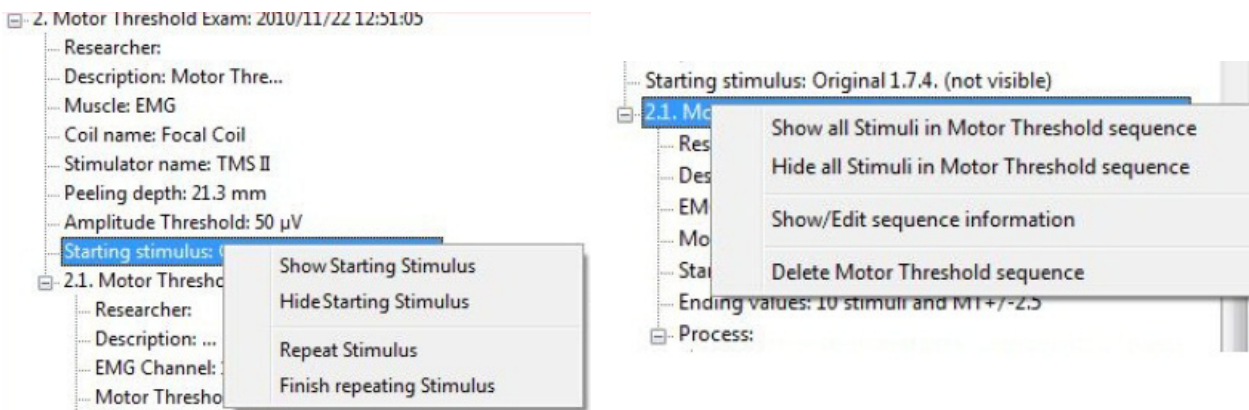


Fig. 115. Pop-up menu for Starting Stimulus (on the left) and for Motor Threshold Sequence (on the right)



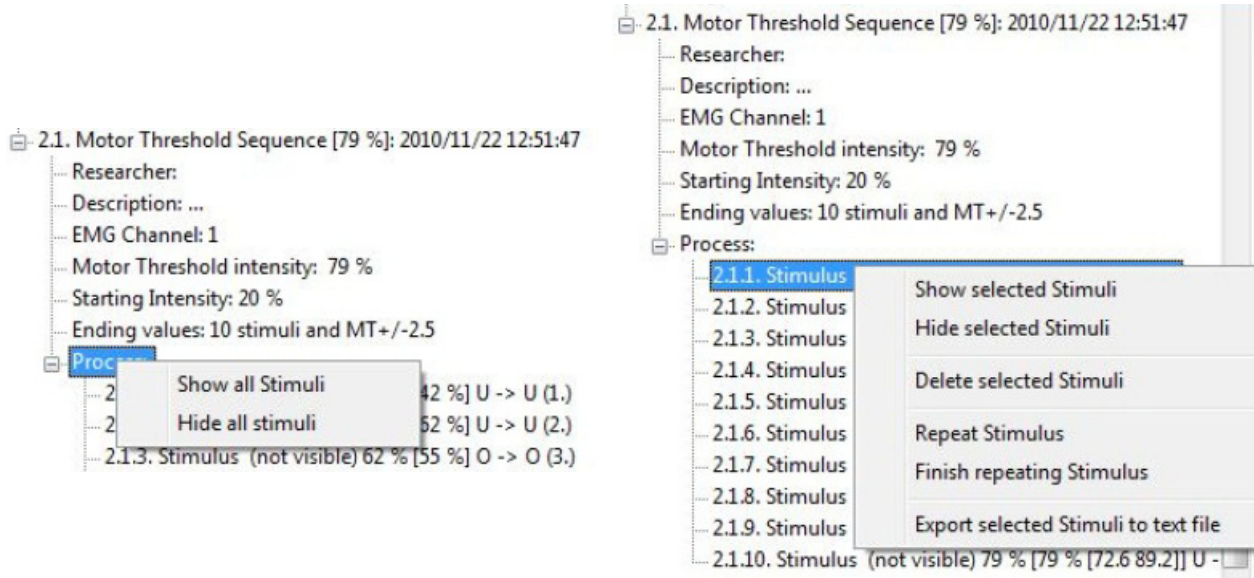


Fig. 116. Pop-up menu for Process (on the left) and for Stimulus (on the right) in a Motor Threshold Sequence

Table 35 Session tree operations for Motor Thresholds and sub-components

Operation	Description
Show/Hide all/selected Stimuli Show/Hide Starting stimulus Show/Hide all Starting stimuli Show/Hide all Stimuli in Motor Threshold Sequence	You are able to control the visibility of stimuli in the 3D view.
Delete all Motor Threshold exams Delete Motor Threshold exam/sequence	You are able to delete MT exams and sequences. Deleting cannot be done during stimulation or digitization.
Delete selected Stimuli	You are able to delete MT stimuli under MT sequences. Deleting cannot be done during stimulation or digitization. The Starting stimulus cannot be deleted.
Show/Edit exam/sequence information	You can give a description for every MT exam/sequence.
Repeat/Finish repeating Stimulus	See Chapter 6.11.9 “Repeating the stimulus”.
Export selected Stimuli to text file	See Chapter 6.14 “Exporting session data”.
Motor Threshold determination	See Chapter 6.12 “Determining Motor Threshold”.

## 6.14 Exporting session data

### NOTE:

Session data is also automatically exported when a session is closed. The automatic export is performed both in plain text and XML formats. Export files *.nbe* and *.nbx* are saved into the *NBSExportFiles* directory. Prefix “*auto\_*” is added to the session file name.

The default location of the created export files is the *NBSExportFiles* directory. You can define another location before saving the file. Exported text files are structured to keep data in columns so that the text is easy to copy into a work sheet (such as Microsoft Office Excel).

1. Right-click **General** in the session tree.
2. Select **Export Session to text file**.

NBS creates two export files: *.nbe* and *.nbx*.

You can open the exported *.nbe* file with a text editor, such as Windows Notepad (Figure 117).

The *.nbx* files are used in NBS Report Maker software. For more information, refer to *NBS Report Maker User Manual*.

ID	Time (ms)	Stim. Type Stim.	Inter pulse Int. (ms)	First Intens. (%)	Second Intens. (%)	Target ID	Rep. Stim. ID	Peeling Depth (mm)	User Resp.	Coil Loc. X (mm)	Y (mm)
6.5.16.	133105	Single	-	56	-	-	6.2.33.	24.1	-1.0	190.4	218
6.5.17.	139564	Single	-	56	-	-	6.2.33.	24.1	-1.0	191.7	218
6.5.18.	144012	Single	-	56	-	-	6.2.33.	24.1	-1.0	191.7	218
6.5.19.	153747	Single	-	56	-	-	6.2.33.	24.1	-1.0	185.4	218
6.5.20.	169369	Single	-	56	-	-	6.2.33.	24.1	200.0	186.8	218
6.5.21.	175717	Single	-	56	-	-	6.2.33.	24.1	300.0	186.9	220
6.5.22.	182980	Single	-	56	-	-	6.2.33.	24.1	250.0	187.6	218
6.5.23.	188462	Single	-	56	-	-	6.2.33.	24.1	-1.0	187.3	220
6.5.24.	197861	Single	-	56	-	-	6.2.33.	24.1	-1.0	185.3	220
6.5.25.	206412	Single	-	56	-	-	6.2.33.	24.1	28.0	182.8	220
6.5.26.	211604	Single	-	56	-	-	6.2.33.	24.1	29.0	183.0	220

Fig. 117. Example of a data export file

3. Save the text file.

The session export file provides a concise summary of the stimulation session, by providing all information in a single table. The session export table is preceded by the basic user-provided session information given to the NBS:

- Organization information (session creation date, researcher, and description)
- Patient information (name, age, gender, handedness, and ID)
- Used coordinate system
- Landmarks (mm)
- Stimulation targets (mm)

- Exam information (creation date, researcher name, description)
  - MT exam information includes also: Muscle, coil and stimulator name, peeling depth, amplitude threshold and starting stimulus ID.
- Sequence information (creation date, coil name, stimulator name, description)
  - MT sequence information includes also: EMG channel number, MT intensity, starting intensity and sequence ending parameters.

Table 36 Export file field values (all fields may not show, depending on the exam/sequence/stimulus type)

Field name	Definition	Value
ID	Stimulus ID (consists of exam, sequence, and stimulus ID numbers)	1.1.1...n.n.n
Time (ms)	Time since the start (first stimulation pulse) of the sequence	0-n milliseconds
Stim. Type	Stimulation type	single
Inter pulse Int. (ms)	Time interval between pulses	1...n ms
First Intens. (%)	Stimulation pulse intensity	Intensity
Second Intens. (%)	Second stimulation pulse intensity	Intensity
Target ID	User defined MRI target ID as a reference for the stimulus	1..n
Rep. Stim ID	Repeated stimulus ID (consists of exam, sequence, and stimulus ID numbers)	1.1.1...n.n.n
Peeling Depth (mm)	Relative depth at which the electric field is calculated	0...50 mm
User Resp.	User-defined response value	n
Coil Loc. x (mm)	Coil location position according to its x-axis	User-selected coordinate system
Coil Loc. y (mm)	Coil location position according to its y-axis	User-selected coordinate system
Coil Loc. z (mm)	Coil location position according to its z-axis	User-selected coordinate system
Coil Normal x	x-component of normal unit vector 90 degrees downward from the bottom of the coil	-1...1
Coil Normal y	y-component of normal unit vector 90 degrees downward from the bottom of the coil	-1...1
Coil Normal z	z-component of normal unit vector 90 degrees downward from the bottom of the coil	-1...1
Coil Dir. x	x-component of normal unit vector giving the facing of the coil	-1...1
Coil Dir. y	y-component of normal unit vector giving the facing of the coil	-1...1
Coil Dir. z	z-component of normal unit vector giving the facing of the coil	-1...1
EF max. Loc. x (mm)	Maximum electric field location according to its x-axis	User-selected coordinate system
EF max. Loc. y (mm)	Maximum electric field location according to its y-axis	User-selected coordinate system
EF max. Loc. z (mm)	Maximum electric field location according to its z-axis	User-selected coordinate system

Table 36 Export file field values (all fields may not show, depending on the exam/sequence/stimulus type)

Field name	Definition	Value
EF max. Value (V/m)	Maximum electric field value at selected peeling depth	0...n volts per meter
EF at Target (V/m)	Electric field at the selected active MRI target	0...n volts per meter
Ch1-6 Amp ( $\mu$ V)	Amplitude of the EMG channel in microvolts	0...n microvolts
Ch1-6 Lat. (ms)	Latency of the EMG channel response in milliseconds	0...n milliseconds

The following information are exported from the Defined series sequences:

- Defined series Sequence creation date and time
- Defined series Sequence ID
- Coil name
- Stimulator name
- Sequence description
- Completion status
- Defined series parameters: file name, description, total time, interstimulus interval range, intensity range, base intensity
- Defined series Reference stimulus ID
- Defined series Run details: Start and end time, actual runtime, time paused, delivered number of pulses, delivered intensity range, used base intensity
- List of stimuli (as in Table 36).

The following information are exported from the rTMS sequences:

- rTMS Sequence creation date and time
- rTMS Sequence ID
- Coil name
- Stimulator name
- Description
- Sequence parameters: Sequence program description, intensity ramp up, pulse frequency, pulse intensity, pulses in a burst, bursts in a train, time between bursts, trains in a sequence, time between trains, planned duration, planned number of pulses, target ID
- rTMS reference Stimulus information: ID, repeated stimulus ID, e-field of reference stimulus at used depth, peeling depth, coil location, coil normal, coil direction
- rTMS Sequence details: Start time and date, duration, planned and delivered, location control, number of stimuli 0-10 mm, >10-20 mm and >20 mm from reference.

From MT exams, all information is exported including EMG response values and classification history. MT stimuli coordinates are those selected at the time of exporting.



## 6.14.1 Exporting stimulation data to text file

1. Select one or more stimuli from the session tree or Analysis Table.
2. From the pop-up of many or any selected stimulus, select **Export selected stimuli to text file**.
3. Save the file.

## 6.14.2 Exporting digitization data to text file

You can export digitization points in an exam to a text file.

The export file coordinates are the ones selected at the time of exporting. The selected coordinate system is shown in the file.

In addition to the digitization points, the physical and anatomical landmarks used in registration are also saved in the file.

1. Right-click **Digitization Exam** or **Digitization Points** in the session tree,  
OR  
Select **Export Digitization exam** from the menu of the **Digitization Exam** or **Digitization Points**.
2. Save the file.

## 6.14.3 Saving screenshots

The Nexstim NBS display views can be exported to picture files (at any time of the program). The exported picture files are saved under the specific session directory, in the *Screenshot* folder.

1. Right-click **General** in the session tree. Select **Save Screenshot (Ctrl+S)**  
OR  
Press CTRL+S. (Use this if you want to take a screenshot showing EMG data of a stimulus.)
2. Check that a BMP file is created in the session-specific directory: *C:\Nexstim\NBS 4.3\NBS\SessionFiles\[session directory name]\Screenshot*.  
The name of the BMP file is formed as "*session name*" \_ "*date\_of\_image*".*bmp*.
3. Rename the screenshot file to a more descriptive one, if needed.

## 6.15 Using analysis exams

Stimuli can be copied to analysis exams for further analysis. Thus, the original stimuli are not modified. In addition, an analysis exam may contain stimuli from several sequences of different types.

### 6.15.1 Creating analysis exams

In the session tree, right-click on the specific item, of which you want to create an analysis exam and select **Create new Analysis exam**.

If you create an analysis exam from the sequence pop-up menu, you may also add all stimuli from the sequence to the analysis exam.

### 6.15.2 Activating and disabling analysis exams

To set an analysis exam active, right-click on the exam and select **Set as active Analysis exam**.

To disable an active analysis exam, right-click on the exam and select **Disable active Analysis exam**.

---

**NOTE:**

One analysis exam at a time can be active. Therefore, when an exam is activated, the previously activated exam will be deactivated.

---

### 6.15.3 Adding stimuli to analysis exam

---

**NOTE:**

rTMS reference stimuli cannot be added to an analysis exam at the same time with other types of stimuli.

Before stimuli can be added to analysis exam, it must be set as active.

---

In the session tree, select the stimuli you want to add to the analysis exam.

Stimuli from Stimulation sequences and Defined series sequences can be added to an active analysis exam using the pop-up menu command **Add to active Analysis exam**.

rTMS reference stimuli can be added to an active analysis exam in two ways:

- To add all rTMS reference stimuli under the selected stimulation exam, select **Add all rTMS reference stimuli to active Analysis exam** from the Stimulation Exam pop-up menu.

- To add single rTMS reference stimulus, select **Add to active Analysis exam** from the rTMS reference stimulus pop-up menu.

## 6.15.4 Opening the Analysis Table

---

### NOTE:

You cannot open the Analysis Table during an active stimulation sequence.

When opening the Analysis Table, the stimuli turn gray. When closing the Analysis Table, the stimuli turn back to their original colors.

When opening the Analysis Table, only the stimuli in the table are visible. When you select a stimulus not belonging to the opened Analysis Table, the stimulus is displayed with its original color.

Selecting **Refresh** in the Analysis Table actually updates the stimuli shown in the table to the current peeling depth. To protect the stimuli in a stimulation sequence, it is recommended to move them to an analysis exam and then analyze the stimuli.

---

1. In the session tree, select **Open Analysis table** from the pop-up menu.
2. The **Analysis Table** -dialog opens. See Figure 118 and Table 37.

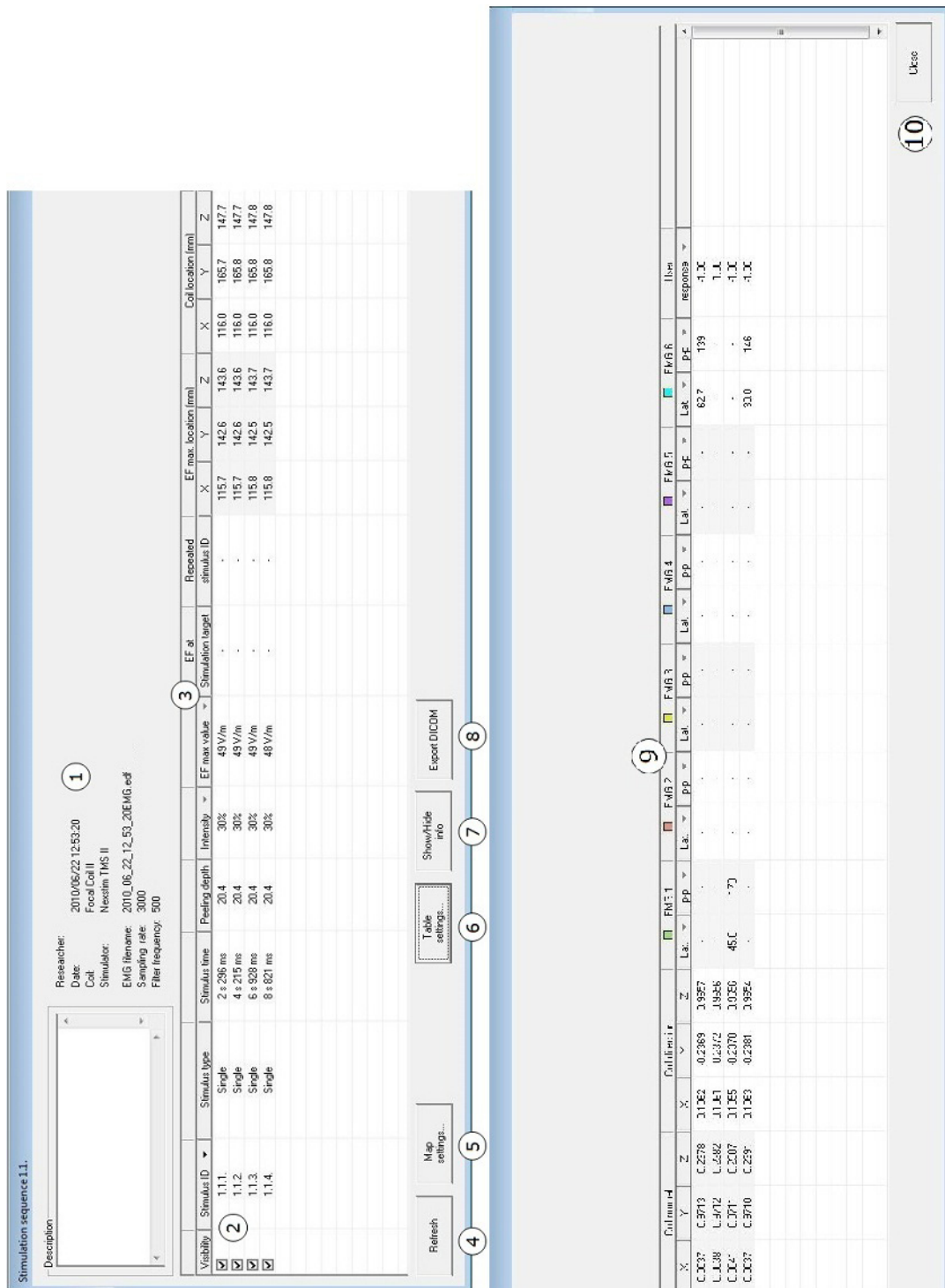


Fig. 118. Analysis Table (divided in two views)

Table 37 Analysis Table settings

1	Info field	<p>The info field contains the following information:</p> <ul style="list-style-type: none"> <li>• Researcher</li> <li>• Date</li> <li>• Coil</li> <li>• Stimulator</li> <li>• Description</li> <li>• EMG filename</li> <li>• Sampling rate</li> <li>• Filter frequency</li> </ul>
2	Stimulus rows	<p>Each stimulus in the set of stimuli is assigned a separate row in the table. From each stimuli a pop-up menu can be opened.</p>
3	Information columns	<p>The stimulus data column headers are: Visibility, Stimulus ID, Stimulus type, Stimulus time, Peeling Depth, Intensity, EF Max Value, EF at Stimulation target, Repeated stimulus ID, EF max. location (mm), Coil location (mm), Coil normal, Coil direction, EMG 1-6; Lat. p-p., User Response.</p> <p>In the example above, each EMG channel displays the latency and peak-to-peak values of the EMG response. Information columns can be defined with the <b>Table settings</b> -button (5). Column information can also be sorted ascending or descending by clicking the arrow next to the column name.</p>
4	<b>Refresh</b>	<p>Updates the stimuli to the current peeling depth and recalculates the values. Also refreshes the map (colors of stimuli) for the visible stimuli according to the <b>Map Settings</b> -dialog.</p>
5	<b>Map settings...</b>	<p>Opens the <b>Map settings</b> -dialog, where you can select the map type (see Figure 120 on page 146).</p>
6	<b>Table settings...</b>	<p>Opens the <b>Table settings</b> -dialog, where you can select the information columns displayed on the Analysis Table (see Figure 119 on page 145).</p>
7	<b>Show/Hide info</b>	<p>Shows/hides the info field. The edited text will be saved to the session data when the Analysis Table is closed.</p>
8	<b>Export DICOM</b>	<p>Opens the <b>Export DICOM</b> -dialog (see Figure 125 on page 154).</p>
9	EMG channels	<p>Each EMG channel from 1-6 can be displayed in the Analysis Table. The identifying color is displayed next to the channel number.</p>
10	<b>Close</b>	<p>Closes the Analysis Table window. The color of stimuli in the Analysis Table are returned to orange. Note that the peeling depth is not returned to original settings.</p>

### Selecting stimuli in the Analysis Table

Click the left mouse button to select a stimulus.

- To select successive multiple items, hold the SHIFT key and select the first and last items. All the objects inbetween will also be selected.

- To select separate single items, hold the CTRL key and select the items by clicking on them.

The selected stimuli rows are displayed in blue background.

The selected stimuli are set visible in the 3D view according to selections in the **Settings**-tab.

---

**NOTE:**

The electric field is displayed only when one stimulus is selected.

---

### **Controlling the stimuli visibility**

Use the check box in the “Visibility” column to set the visibility status of a stimulus. Also pop-up menu commands may be used.

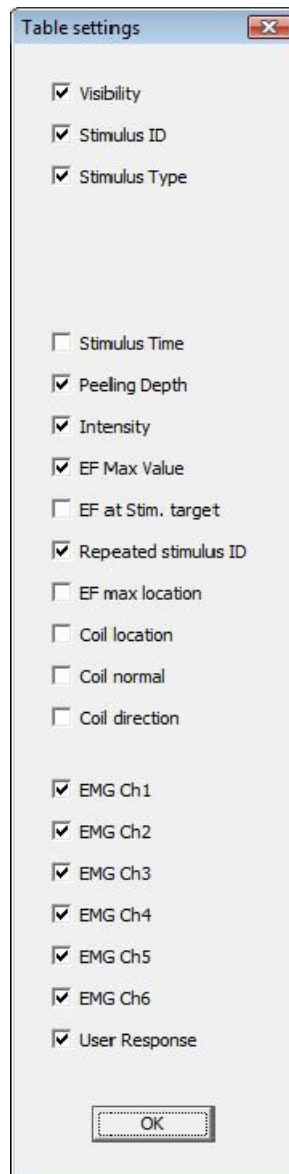
The information on the stimulus visibility in the session tree view is updated according to the visibility status set in the Analysis Table. Accordingly, the check box status in the Analysis Table is updated when the stimulus visibility is changed from the session tree or from Analysis Table by using the pop-up menu.

The 3D head view is updated according to visibility selections.

For non-navigated stimuli, you cannot set the Visibility check box to “Checked” state.

### **Selecting the Analysis Table settings**

Clicking the **Table settings...** -button on the Analysis Table opens the **Table settings** -dialog, where you can use the check boxes to select the information columns displayed on the Analysis Table.

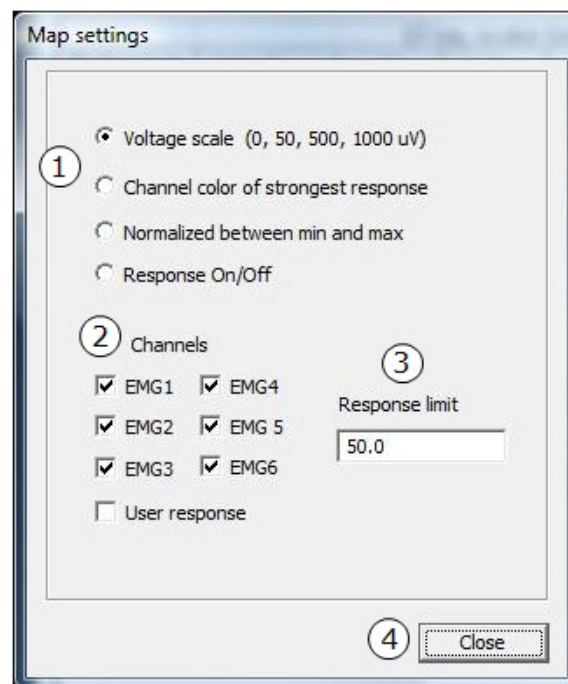


**Fig. 119.** Table Settings -dialog

Clicking **OK** closes the dialog.

### 6.15.5 Selecting map types

There are four types of maps accessible through the **Map settings...** -button of the Analysis Table. See Figure 120 and Table 38.



**Fig. 120.** Map settings -dialog

Table 38 Map settings

1	Map type	Select which type of map to generate; see below for details.
2	Channels	Select the EMG channel for the generated map, from 1-6 or all channels. Instead of EMG responses, you may select the user response column. The user response column values can be edited to any value, meaning that the user can input response values from which to draw an analysis map.
3	Response limit	Enter the microvolt limit considered as no response.
4	<b>Close</b>	Closes the dialog and changes the colors in the 3D view.

#### Voltage scale

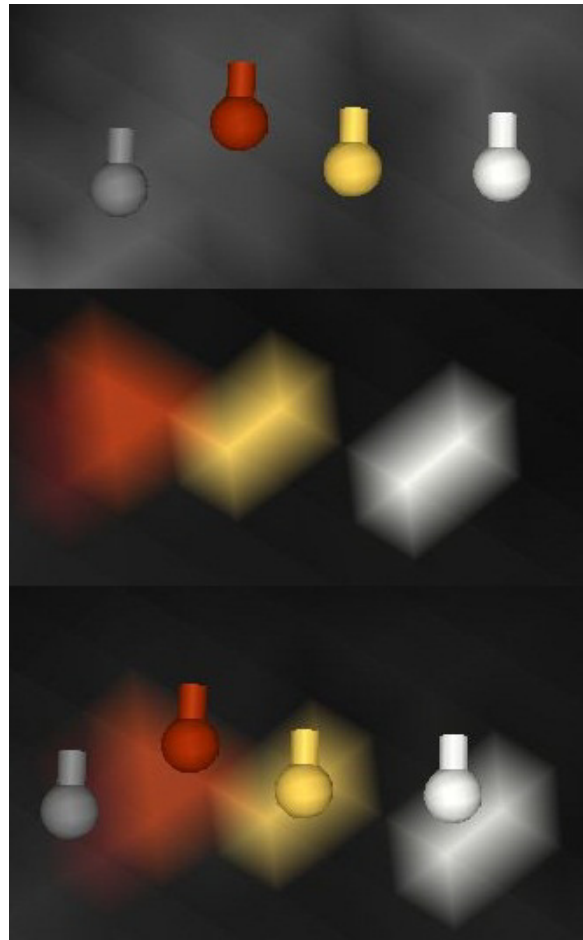
The map generated on the 3D image of the NBS main view assigns the following colors to individual stimuli:

- Response between 0-50 microvolts: Gray
- Response between: 50-500 microvolts: Red
- Response between 500-1000 microvolts: Yellow



- Response above 1000 microvolts: White.

An example of a Voltage scaled EMG response mapping is shown in Figure 121.



**Fig. 121.** Example of stimuli, DICOM export overlay (“Heat colormap”), and their combination shown on the 3D head when the “Voltage scale” mapping is selected

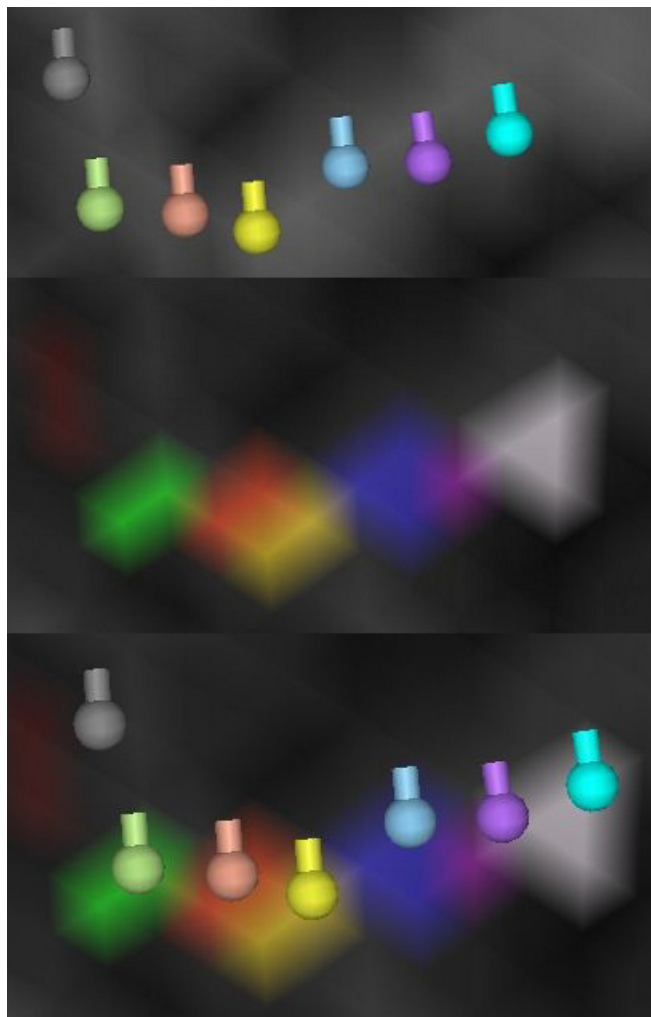
### Channel color of strongest response

The “Channel color of strongest response” type of map cannot be viewed during an active measurement/stimulation session; it can only be used as a post-session analysis tool. This map assigns the EMG-channel color to stimuli having EMG responses that exceed the response limit value according to the classification explained below. A stimulus is colored gray if all responses are below the response limit value.

This feature intends to display an overview of the cortical muscle representations. The stimuli are colored by comparing the amplitudes of motor evoked potentials (MEPs) recorded simultaneously from different EMG channels and then assigning each stimulus the color of the EMG channel giving the strongest normalized response.

Before a stimulus color is determined, the responses from each EMG channel go through variance normalization. After this operation the responses of a given channel have zero mean and unit variance. This scales the responses measured from different channels to a comparable level despite the differences in absolute values of the responses. As a result, channels with relatively weak responses are better visualized.

Nexstim recommends that the feature “Channel color of strongest response” is not used to make judgments about the somatotopic order of representation areas. Nexstim advises to use all responses from individual EMG channels separately. An example of “Channel color of strongest response” EMG mapping is shown in Figure 122.



**Fig. 122.** Example of stimuli, DICOM export overlay (“Rainbow colormap”), and their combination shown on the 3D head when the “Channel color of strongest response” mapping is selected

## Normalized between min and max

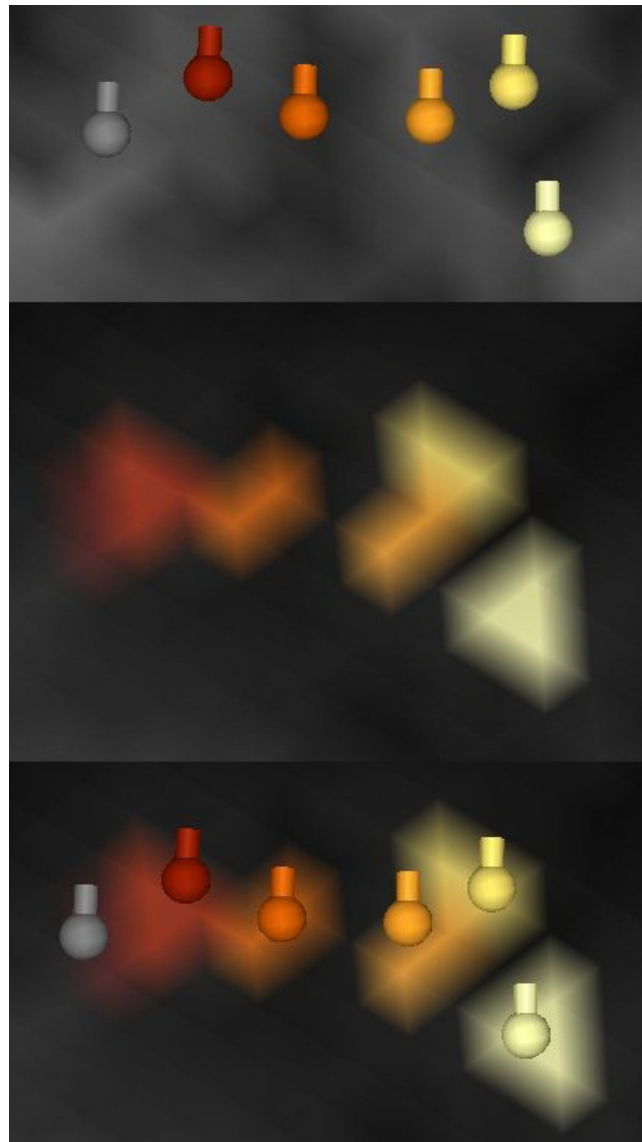
The “Normalized between min and max” type of map intends to display relative strength of motor responses. The map type cannot be viewed during an active measurement session; it can only be used as a post-session analysis tool.

Before a stimulus color is determined, the responses from selected EMG channels go through variance normalization. After this operation the responses of a given channel have zero mean and unit variance. This scales the responses measured from different channels to a comparable level despite the differences in absolute values of the responses. As a result of the normalization, channels with relatively weak responses are better visualized.

Each response symbol is then assigned with a color based on a “heat” colormap:

- No response (below the response limit): Gray
- The smallest value: Red
- The biggest value: White
- All values inbetween are linearly scaled between red and white.

An example of “Normalized between min and max” EMG response mapping is shown in Figure 123:

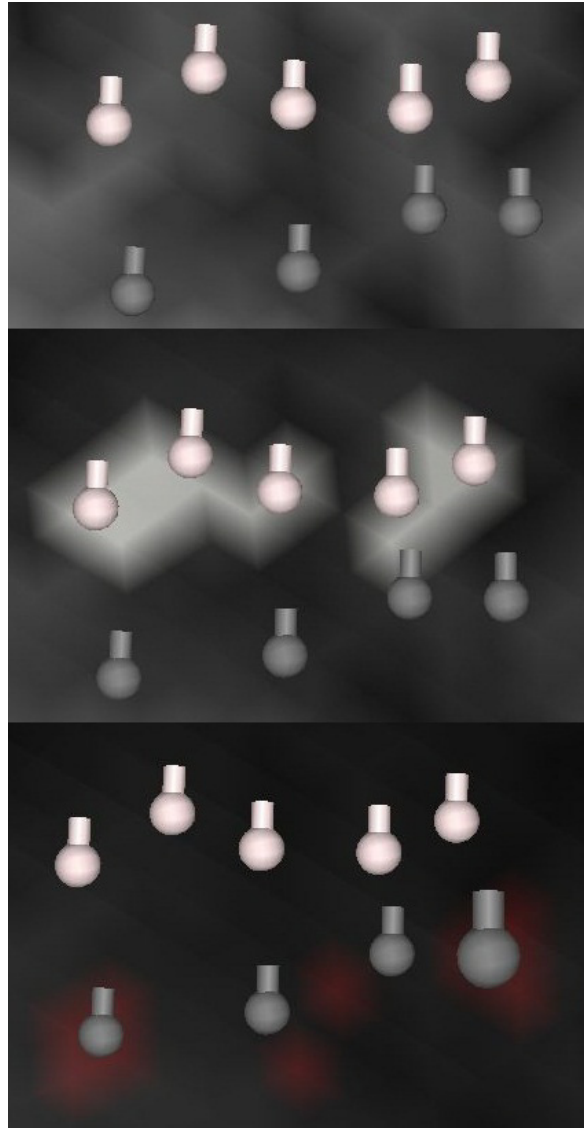


**Fig. 123.** Example of stimuli, DICOM export overlay (“Heat colormap”), and their combination shown on the 3D head when the “Normalized between min and max” mapping is selected

### Response On/Off

If “Response On/Off” is selected, the stimulus indicators are colored gray or white, depending on the response values. The response values of all selected channels are compared to value that is set in the “Response limit”. If any of them is above the response limit value, the stimulus indicator color is set to white. Otherwise the color is gray.

Figure 124 shows an example of stimuli (above and below the response limit) and with the DICOM export overlay (“Heat colormap”) shown on the 3D head when the “Response on/off” mapping is selected. The middle figure shows the DICOM export overlay of stimuli above the response limit, and the bottom figure shows the DICOM export overlay of stimuli below the response limit.



**Fig. 124.** Example of “Response on/off” mapping and the two DICOM exports generated (“Heat colormap”).

## 6.16 Transferring session data to external systems using DICOM export

Stimuli in Analysis Table can be exported as series of DICOM images. Exports come in two forms: overlay images and fusion images. Both types of export images contain painted voxels at the locations of the stimuli at the selected peeling depths.

**Overlay images** can be loaded on top of the original MR image that was in use when the overlay export was created. For overlay images, the color of the voxels depends on the map settings of the NBS, and the locations of the (stereotactic) landmarks (of the head) are marked by coloring the voxels and copying a small area of original MR image to the exported DICOM image, so that the end-user can verify that the exported DICOM image is loaded correctly over the correct MR image.

**Fusion images** contain, in addition to the stimuli, a copy of the original MR image, and can thus be used to avoid the scenario of loading images on top of images. Because the fusion image is aligned during exportation, there is no need to use landmarks to verify image alignment. The DICOM fusion export contains voxels colored with white (maximum brightness) generated by the NBS and written on top of a copy of the original MR image.



### **PRECAUTION:**

When exporting coordinates from the NBS system, ensure that the coordinate system of the other equipment is compatible with the NBS coordinate system.

---

### **NOTE:**

The DICOM export and DICOM screen capture can be done only from images that are in DICOM format.

---

## 6.16.1 Generating DICOM export

---



### PRECAUTION:

#### For DICOM overlay images:

When using the “Voltage scale”, “Normalized between min and max” or “Response On/Off” map types, note that if several stimuli are located on the same spot, the highest color index (that is, the strongest MEP value) will be written to the DICOM export.

When using the “Channel color of strongest response” map type, and if several stimuli are located on the same spot:

- EMG6 may overwrite EMG5.
- EMG5 may overwrite EMG4.
- EMG4 may overwrite EMG1.
- EMG1 may overwrite EMG3.
- EMG3 may overwrite EMG2.
- EMG2 may overwrite the user response or all stimuli below the response limit.

Do not change the original orientation of DICOM export stack.

When the DICOM overlay export is generated, load the DICOM export to Nexstim NBS and verify the following:

- Ensure that you have selected the correct colormap.
- Ensure that the landmarks are in correct locations. Check that the copied area around the landmark in the DICOM export matches the MR image.
- To check that the DICOM export is correct, read the text export describing the DICOM export content.
- Ensure that the color scale test icon in the bottom right corner of the DICOM export is displayed correctly. Using the test icon, verify that every stimulus described in the DICOM text export is correctly visualized.

Verify that all exported stimuli, in every selected peeling depth, are visible in the DICOM export. Accept and review every stimulus in the Analysis Table. Check that their color is correct.

---

### NOTE:

Fusion exports are generated only in the context of “Response On/Off” maps.

The stimuli are moved to the selected peeling depths. When the DICOM export is finished, the stimuli are not moved to their original peeling depths.

---

1. In the Analysis Table, ensure that the stimuli you wish to export are set visible and that you have selected the correct map setting.
2. Click **Export DICOM**.
3. In the appearing **Export DICOM** -dialog (Figure 125), you can select the peeling depths you wish to use for the export.

You can select any combination of the peeling depth check boxes. The **Current peeling depth** -check box is active when peeling depth is above 0.0 mm.

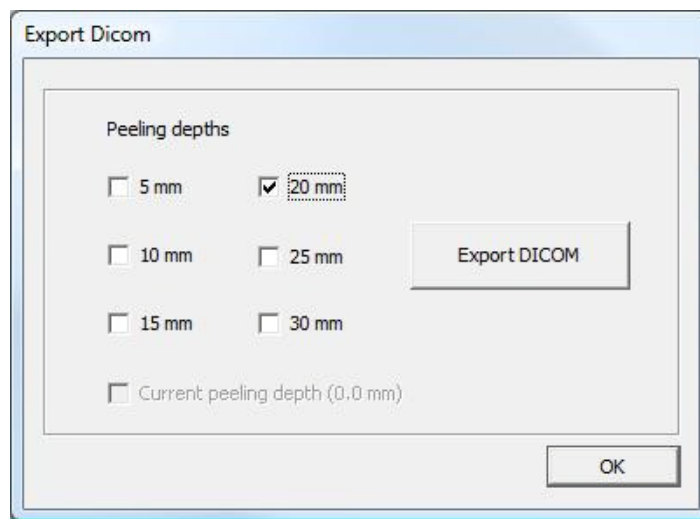


Fig. 125. Export DICOM -dialog

4. Click **Export DICOM**. The button is disabled if none of the peeling depths is selected.





## PRECAUTION:

Compared to NBS, the DICOM export visualization may be different in a third party device. This may lead to incorrect interpretation of the stimuli displayed in the third party device. This is of concern especially when using the “Voltage scale”, “Channel color of strongest response”, and “Normalized between min and max” map types. Therefore, a warning is displayed (Figure 126).

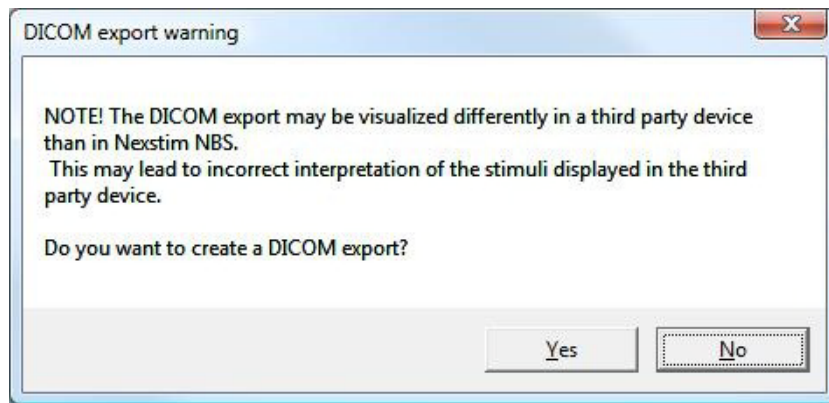


Fig. 126. DICOM export warning -dialog

---

The warning is not displayed when using the “Response on/off” map type.

It is recommended to use the responses below the response limit and responses same as or above the response limit DICOM exports, generated with the “Response On/Off” map setting.

5. If you click **Yes**, the DICOM export will be created.
6. After a successful export, the **Export succeeded** -dialog appears, containing the name of the export directory which was created during the export.
7. Click **OK** to close the dialog.
8. Copy the specific session files (including the *DICOMExport* folder) under *NBS Sessionfiles* to a CD or USB memory stick. This is recommended for loading the DICOM export files in another system.

When using the “Response On/Off” map type, three DICOM exports are generated in the *DICOMExport* session directory:

- Two **DICOM overlay** exports:
  - a) one containing the stimuli, the responses of which are below the response limit (postfix “*\_BELOW*”).
  - b) one containing the stimuli, the responses of which are same as or above the response limit (postfix “*\_ABOVE*”).

- One **DICOM fusion export**:

- c) one the same as “\_ABOVE”, but with the results fused on top of a copy of the original MR image of the patient (postfix “\_ABOVE\_ANATOMIC”).

Every selected peeling depth is displayed in the NBS display and the exported files are generated under a specific *DICOMExport* session directory:

- *C:\Nexstim\NBS 4.3\NBSSessionfiles\[session directory name]\DICOMExport\[DICOM export directory name]*.
- The *[DICOM export directory name]* is the directory that contains all information generated with one DICOM export command. This directory is intended to be copied to the external system.
- The *DICOMFiles* directory contains DICOM image files of the DICOM export.
- The DICOM export creates a text file that describes the content of the DICOM export. It is used for checking that the external system displays the correct DICOM export correctly. It is in format *<patient name>\_<date and time of the export>.txt*.

The DICOM text export contents, and an example of DICOM text export are described in Appendix E: “DICOM export” on page 217.

## 6.16.2 Loading DICOM overlay export

This chapter instructs to load DICOM overlay export to NBS.

You may also load fusion images as DICOM overlay, but they can also be used for creating a new session by copying the fusion images to the *MRI\_DATA* folder.



### PRECAUTION:

When the DICOM overlay export is loaded to Nexstim NBS or to an external system, verify the following:

- Ensure that the DICOM overlay export and MR image are from the same patient. In addition, ensure that the morphological MR image stack to be imported is the very same as the image stack used for mapping in Nexstim NBS.
  - Ensure that you have selected the correct colormap.
  - Ensure that the landmarks are in correct locations. Check that the copied area around the landmark in the DICOM overlay export matches the MR image.
  - To check that the DICOM overlay export is correct, read the text export describing the DICOM overlay export content.
  - Ensure that the color scale test icon in the bottom right corner of the DICOM overlay export is displayed correctly. Using the test icon, verify that every stimulus described in the DICOM text export is correctly visualized.
-

1. Select **Overlay > Load DICOM export** -tab (see Figure 56 on page 74).
2. Select the used colormap (Figure 127).

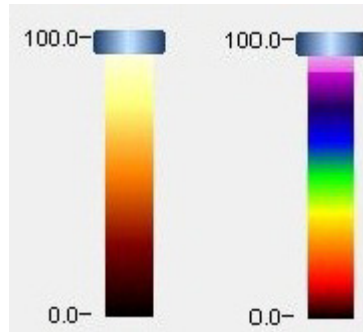


Fig. 127. Transparency slider showing Heat colormap (on the left) and Rainbow colormap (on the right)

3. Select **Show DICOM export**. A dialog is displayed, asking if you want to refresh the DICOM export image list.
4. Click **OK** to refresh the DICOM export image list and then open the **DICOM export image browser** -dialog (Figure 128).

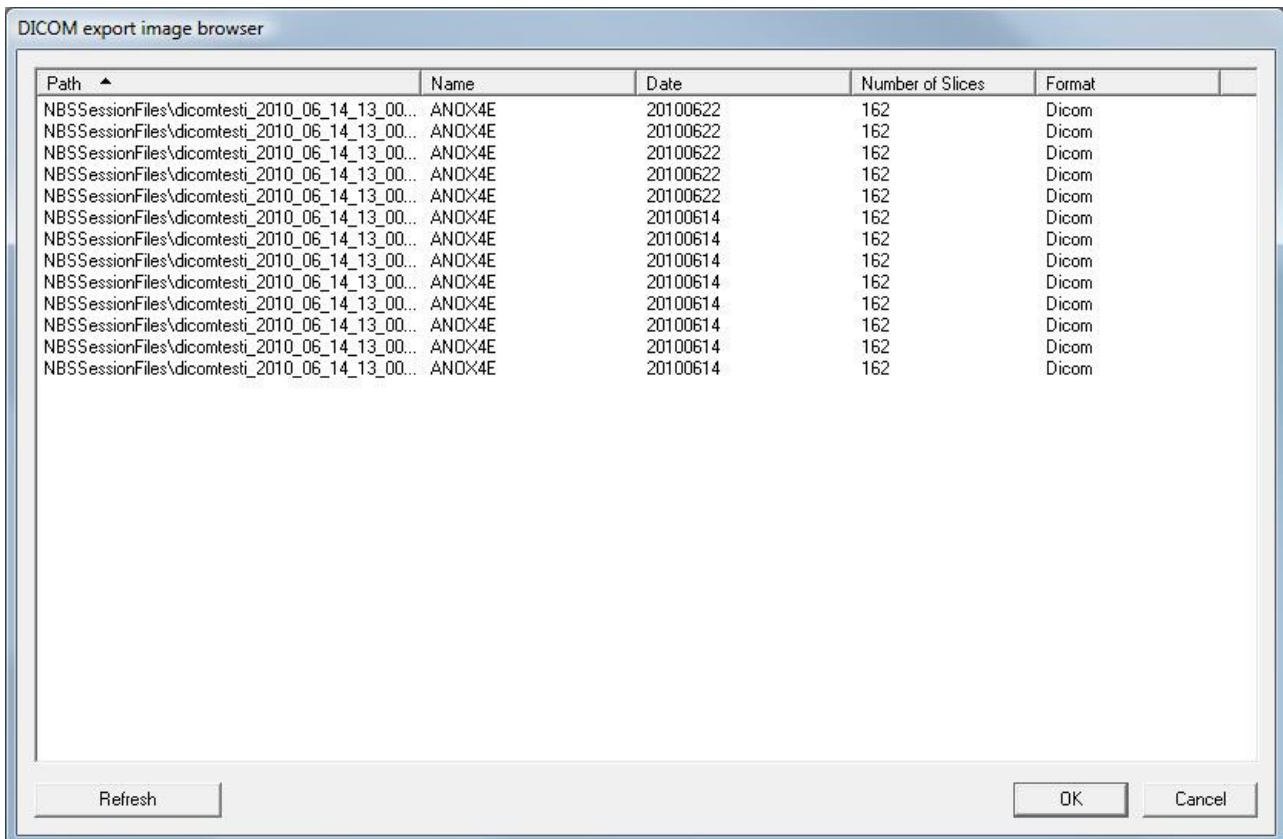


Fig. 128. DICOM export image browser -dialog

The dialog shows the location of the images on the NBS computer, the DICOM stack name, the date of the exam which was exported to the DICOM stack, the number of slices included in the stack, and the format.

5. From the displayed list, select the correct DICOM stack for the session.

To sort the list, click **Path**, **Name** or **Format** on the dialog bar. A small arrowhead indicates the sorting order.

To refresh the contents of the dialog, click **Refresh**.

6. Click **OK** to confirm the DICOM stack selection.

7. The view returns to the **Overlay**-tab. The DICOM export is visualized with the selected colormap.

To change the selected colormap, you have to reload the DICOM export.

### 6.16.3 Locating the color scale test icon in NBS

---

**NOTE:**

This chapter is valid only for DICOM overlay export.

---

The color scale test icon visualizes all color indexes between 0-32767 written in the DICOM overlay image file. The color scale visualization in the test icon is different for each selected colormap. Figure 129 and Figure 130 illustrate the test icons for Heat colormap and Rainbow colormap.

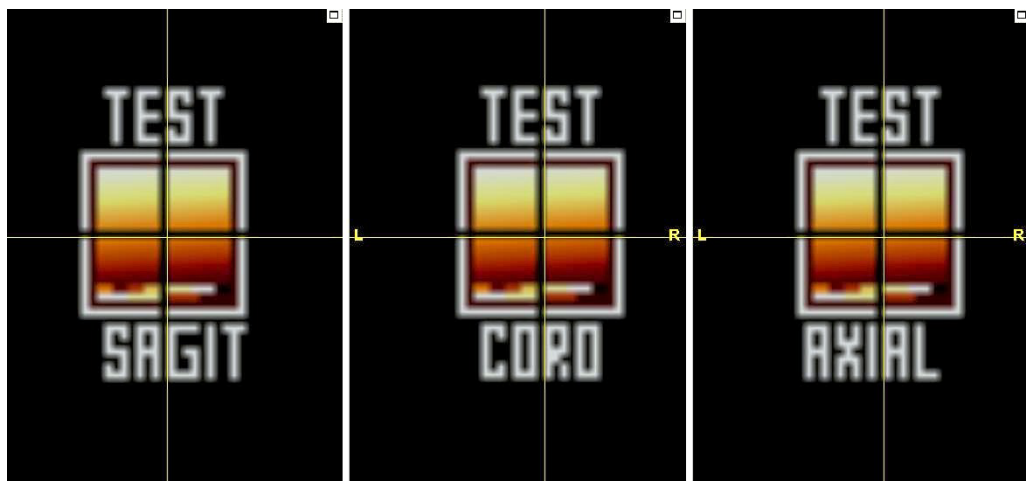
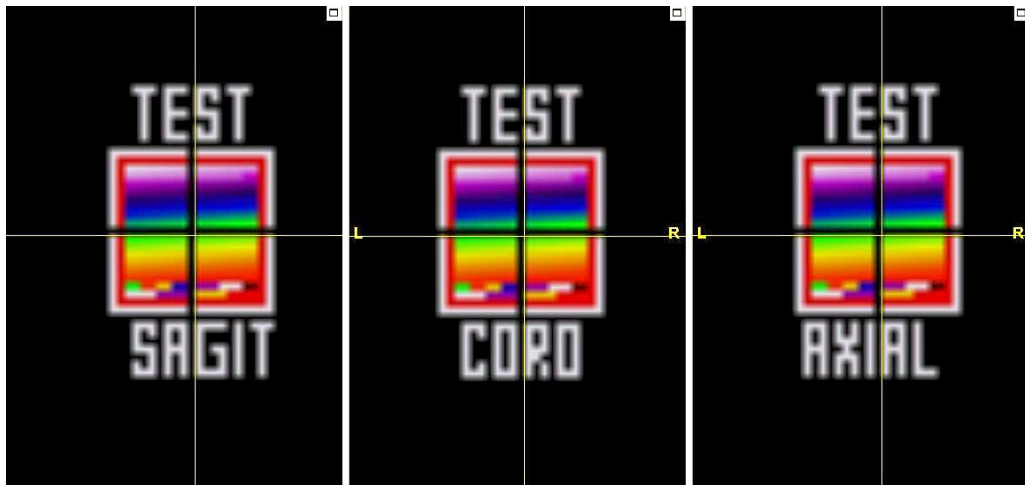


Fig. 129. Color scale test icons: Heat colormap



**Fig. 130.** Color scale test icons: Rainbow colormap

The following procedure describes how to bring forth the color scale test icon in Nexstim NBS. The test icon is located in the bottom right corner of the MR image view, outside the anatomical head.

1. In the **Navigation**-tab, set the Sagittal slider to 0.
2. Position the crosshair in the bottom right corner of the sagittal MR image view.
3. Increase the Sagittal slice scan (mm) value until the color scale test icon becomes visible.
4. You can use the zoom function to improve the visibility of the test icon: Zoom out the MR image so that the anatomical head is displayed as a whole, as well as the bottom right area of the image, until the test icon is displayed.
5. Check that the color scale test icon is correctly displayed (the appearance should be as shown in Figure 129 and Figure 130):
  - a) Check that the icon text “TEST SAGIT” is displayed correctly; that is, the text is not reversed or missing.
  - b) Check that the test icon center forms a uniform square.
  - c) Check that the color scaling is contiguous from up to down. Check that the color scaling matches the colors shown in Figure 129 and Figure 130; depending on the selected colormap. Check that there are no black stripes inbetween the color scale.
6. Perform the above mentioned steps also for Coronal (to locate icon text “TEST CORO”) and Axial (to locate icon text “TEST AXIAL”) MR images.

#### 6.16.4 Adjusting the DICOM export color settings on third party systems

Before viewing the DICOM export images on a third party device, you have to adjust the color settings in your device to ensure that all stimuli described in the DICOM text export are correctly displayed.

**PRECAUTION:****For DICOM overlay images:**

Depending on the visualization properties of the third party device, the color scale test icon visualization may be indistinct. For example, the test icons may be blurry or the colors are different.

---

Follow the procedure in Chapter 6.16.3 to locate the color scale test icons on the third party device. For instructions, refer to the user documentation of the specific device.

After you have located the color scale test icon, adjust the color settings so that the test icons are displayed correctly (as Figure 129 and Figure 130).

## 6.16.5 Capturing the DICOM screen

---

**NOTE:**

The DICOM export and DICOM screen capture can be done only from images that are in DICOM format.

---

The 3D head view can be captured to a file by pressing CTRL+D. The capture is saved as JPG format. If the original image is in DICOM format, the capture is saved also as DICOM secondary capture.

1. Select the 3D head depth you want to capture.
2. Turn and zoom the 3D head to an optimal position.
3. Press CTRL+D.

The *.jpg* file is created in folder:

*C:\Nexstim\NBS 4.3\NBSSessionFiles\[session directory name]\Screenshot.*

If the original image is in DICOM format, also the *.dcm* file is created.

4. Change the capture file names to more descriptive ones, if needed.

## 6.17 Using old session files

This chapter describes how to read (import) old session files into new Nexstim NBS software versions. The information in this chapter is for users who have upgraded their NBS and who want to view and analyze old session files in the upgraded software version.

---

**NOTE:**

New NBS version automatically converts the old version session file to the newest session format after the first opening. The converted session file cannot be opened with the older NBS version. It is strongly recommended to take backups from the old session files before conversion.

---

---

**NOTE:**

Do not open the NBS data recorded with version 3.2, or earlier, with NBS version 4.3.  
For more information, please contact Nexstim.

---

## 6.17.1 Backing up session files

Before installing new NBS software, we recommend you take a backup copy of the session files on your NBS computer. Always follow the detailed instructions delivered with the software upgrade and licensing CD-ROMs.

1. Turn on the NBS computer and log on.
2. Go to *C:\Nexstim\NBS 4.3\NBSSessionfiles* folder.
3. Select all contents from the specific session directory folder.
4. Back up the selected files into another location, for example into a DVD or a CD-ROM.

After installing the new NBS software, you can copy the session files you want to use with the new software into the NBS computer.

## 6.17.2 Importing old session files

You can import session files by opening and closing the old session with a newer version of the NBS software.

When an old session file has been imported to NBS, the electric field values of the stimuli (that have been produced by using older stimulator) cannot be refreshed.





# 7 Examples of Nexstim NBS procedures

## 7.1 Nexstim NBS session in detail

1. Ensure safety:
  - a) Check that Nexstim TMS II Stimulator is correctly connected with the Nexstim EMG and NBS computer.
  - b) Check that there is no visible damage in any system parts (for example, cracks in the stimulation coil casing, coil cord, or power cords).
  - c) Check that there is no visible damage in main cords, connecting cables, or pins.

For more information about the safety instructions, please refer to Chapter 2 “Intended use and safety” on page 13.
2. Check the tracking system unit position. For instructions, see Chapter 4.4 “Polaris tracking system” on page 30.
3. Connect the NBS System to the mains power. It takes about 20 minutes for the tracking system to warm up and stabilize.
4. Turn on the EMG device.
 

The EMG device should be turned on at least 15 minutes before the measurement to allow for the device to warm up.
5. Select the correct coil to be used during the session.
6. Check that the coil trackers are not damaged in any way, and that they are clean and ready for use.
7. Check the markers for any signs of wear (for example, scratches, or grease marks). Change the markers if necessary.
8. Plug in the stimulation coil. For instructions, see Chapter 4.3.1 on page 28.
9. Turn on the NBS computer and log on.
10. Turn the power on from the Nexstim TMS II main power switch.
11. Check that the green indicator light in the TMS II front panel lights up.
12. Load up the MRI image of the patient. (See page 85).
13. Start the Nexstim NBS software. (See Chapter 6.2 on page 85.)
 

When the tracking system is ready to use, the “Tracking unit state” LED in the **Navigation**-tab turns green, the **Enable Tracking unit** -button changes to **Disable Tracking unit**, and the button will be enabled.
14. Start a stimulation session:
  - a) Select **New session** to start a new session with no previous data. (See Chapter 6.4 on page 86.)

OR

- 
- b) Select **Open Session** to continue a former NBS session for the same patient (see Chapter 6.5 on page 89). Open the session you want to continue in the *NBS Sessionfiles* folder.
  15. Set the MRI landmarks as described in Chapter 6.8.1 on page 92.
  16. Set the stimulation target as described in Chapter 6.11.7 on page 114.
  17. Bring in the patient.
  18. Check that the patient has all jewelry removed (such as rings, necklaces, earrings, and piercings) and is not wearing a watch.
  19. Check that the patient does not have in the pockets any items that could either:
    - disturb the stimulation session (for example, a mobile phone), or
    - be damaged by the stimulation device (for example, a credit card or an ID-card with a magnetic stripe).
  20. Position the patient:
    - a) Make sure that the patient is comfortably seated in the chair. Adjust the patient chair, if needed.
    - b) Adjust the tracking unit position according to the patient's head position.
- 

**NOTE:**

Stimulation sessions can only be successful when the patient is relaxed, and there is no tension in the monitored muscles. It is therefore of utmost importance to ensure that the patient is comfortably seated in the chair.

The tracking unit has a limited field of view and the camera should be within a specified range from the patient's forehead. (See Chapter 4.4 "Polaris tracking system" on page 30.)

---

21. Attach the registration sticker to the patient's forehead.
22. Assist the patient with wearing the adjustable head tracker. (See page 34.)
23. Assess the camera positioning as described in Chapter 4.4.2 on page 32.
24. Attach the EMG electrodes to the patient. (See page 39.)
25. Select the EMG channels and click **Start EMG** in the **Stimulation > EMG**-tab. (See Chapter 5.10.1 on page 58.)
26. Verify that the EMG data shows no interference.
  - If there is interference, refer to the checklist in Chapter 9.16 on page 185.
27. Check that all persons present are wearing ear plugs.
28. Digitize the same three points on the scalp that are marked in the MR images (see Chapter 6.8.2 on page 95).
29. Perform advanced registration. (See Chapter 6.8.3 on page 97).
30. Verify the registration. (See Chapter 6.8.4 on page 98).

31. Perform digitization and the registration integrity test. (See chapters 6.8.5 on page 99 and 6.8.6 on page 100).
  32. Perform the stimulation/mapping. A motor mapping typically consists of three main procedures:
    - a) Performing preliminary motor mapping, that is, locating motor hotspots for the muscles being monitored with EMG.
    - b) Determining the Motor Threshold (MT).
    - c) Performing motor mapping with 110% of the measured MT in order to obtain a good understanding of the functional areas.
- 

## NOTE:

If you suspect that the head tracker has moved in relation to the head during the stimulation session, check that the head tracker is on firmly, and reregister.

To prevent the head tracker from moving, the patient should keep a relaxed expression on his/her face during the stimulation session.

When moving your hands near the patient's head you may accidentally touch the head tracker and move it. If this should happen, you need to restart registration.

Similarly, any sudden movement of the patient (such as sneezing or coughing) necessitates re-registration. Furthermore, if it can be suspected that the head tracker has moved in relation to the head at any point during the examination, re-registration is necessary.

---

33. Carefully remove the head tracker from the patient.
34. Detach the EMG electrodes from the patient.
35. In the **Stimulation**-tab, select **Stop EMG**.
36. Assist the patient out of the chair. / Move out the patient in bed.
37. End the session.
38. Turn off all equipment.
39. Check the markers. Change them if needed.
40. Clean the trackers if needed.
41. Now you can perform the post-processing (for example, analyze the EMG/MEP, review the mapping results) or create DICOM export.

## 7.2 Mapping a specific muscle

### 7.2.1 Coil orientation and EMG responses in mapping

The amplitudes of EMG responses elicited by magnetic stimulation depend on the orientation of the coil, and thus, direction of the induced electric field. In many cases with healthy subjects, strongest responses are elicited when the coil orientation is kept perpendicular to the central sulcus. Also, with healthy subjects, the location of the primary motor cortex can be predicted quite reliably from anatomy and the mapping can be focused on a smaller area.

When mapping is used as a part of presurgical evaluation, it is important to map carefully the areas adjacent to the anomaly (for example, tumor or oedema).



#### **PRECAUTION:**

The EMG measurement is sensitive to external disturbances. Detection threshold of 50  $\mu\text{V}$  is recommended for motor-evoked potentials. Operation of the equipment below this value may cause incorrect results.

---

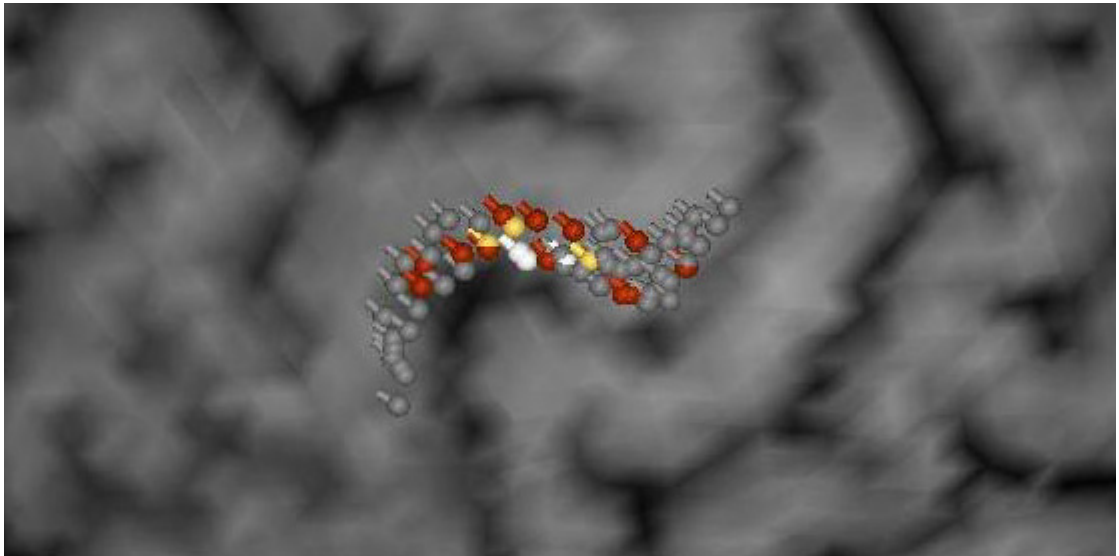
### 7.2.2 Example of mapping a specific muscle on a healthy subject

In this example, the thumb (Abductor pollicis brevis muscle, APB) of the subject is mapped to the 3D head display by stimulating the motor cortex and identifying the EMG responses.

EMG electrodes have been attached to the right thumb of the subject. Therefore, the stimulation area will be in the left hemisphere's motor cortex.

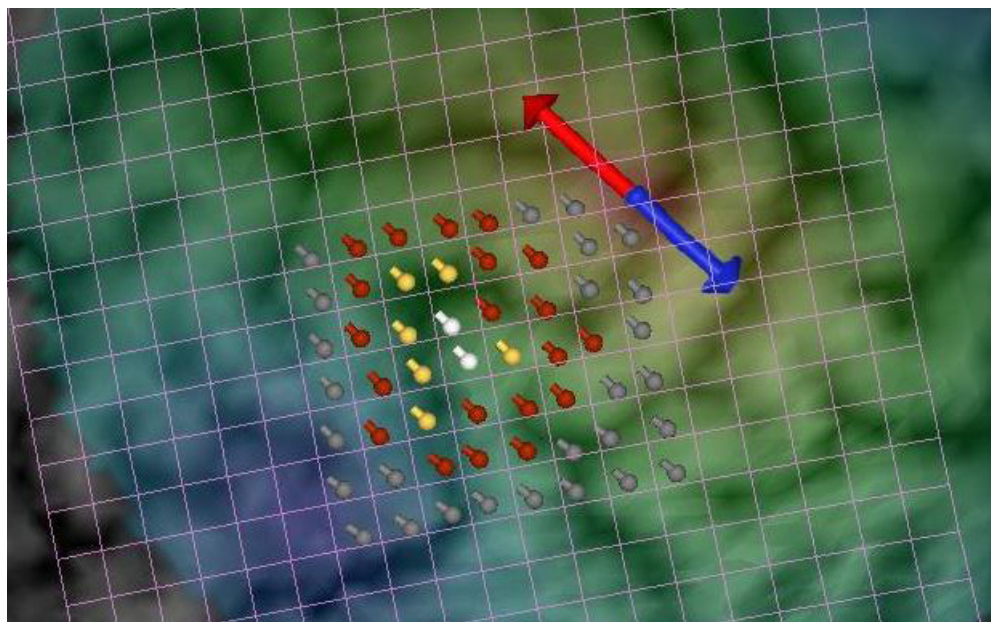
In Figure 131, stimuli have been given along the motor cortex, using the "Voltage scale" map type to find the largest response value. Stimuli are given around the presumed APB location in different directions to determine the optimum stimulus location, and with an intensity as small as possible for maximum responses approximately 100-500  $\mu\text{V}$ .

Optimization of the rotation means that once the motor hotspot has been located, the stimuli will be delivered in the same spot varying the rotation of the coil. The aim is to find the best orientation for the coil.



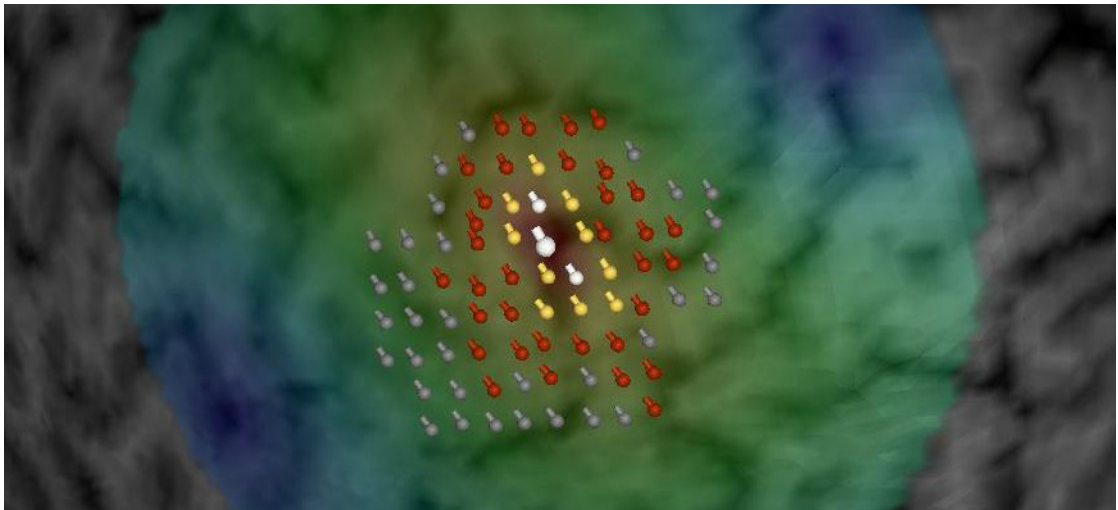
**Fig. 131.** Finding the largest EMG response along the cortex (Voltage scale map setting)

Stimuli are delivered around the previously discovered highest response stimulus (motor hotspot) until no responses are obtained (Figure 132). All stimuli are delivered using the coil direction of the motor hotspot.



**Fig. 132.** Isolating the response area (target grid visible)

The shape of the mapped area corresponds with the shape of the electric field as shown in Figure 133.



**Fig. 133.** The shape of the mapped area

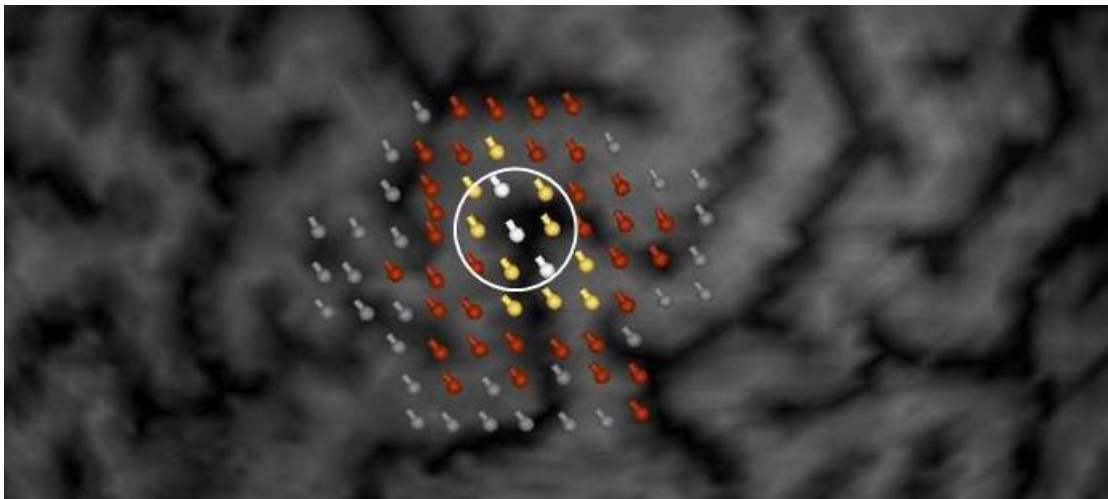
Based on these results, the thumb area can be pinpointed at the center of the mapped area, encircled in Figure 134.

---

**NOTE:**

Colored stimulus indicators do not mean that the reacting muscle is directly underneath the indicator.

---



**Fig. 134.** Thumb area pinpointed

### 7.2.3 Example of multiple responses and multiple muscle mapping

When a single channel provides two definite response areas, responses may originate from the pre-motor muscle area and primary motor muscle area, shown in Figure 135, where the subject's right thumb has been mapped with two muscle area responses (encircled with yellow), and the subject's right leg muscle has been mapped with one area (encircled with purple). This example shows that the thumb muscle responses are received from both the pre-motor and primary motor cortices.

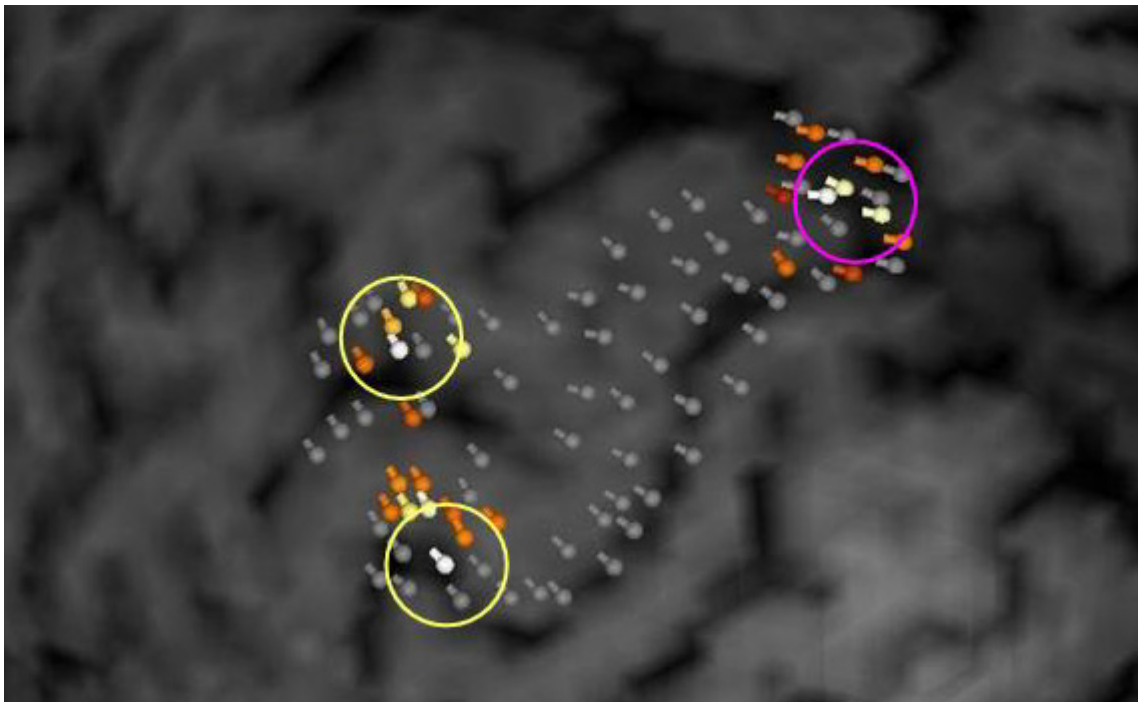
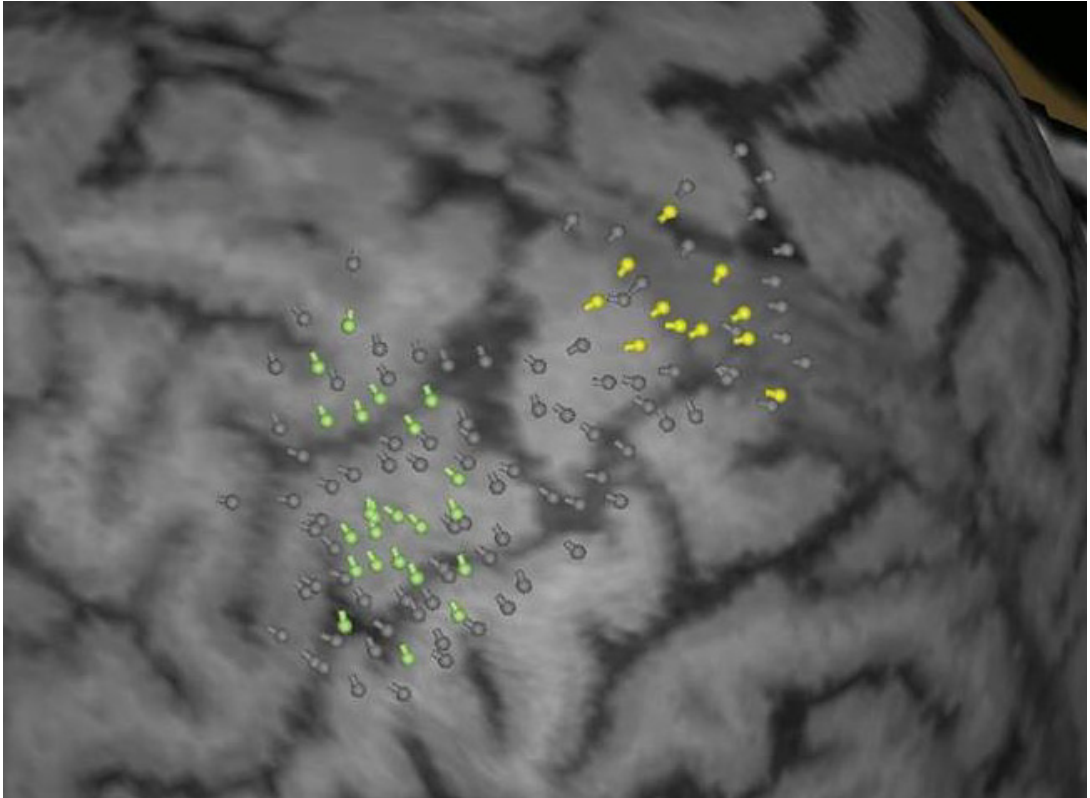


Fig. 135. Multiple muscles and responses



In post-stimulation analysis, channel-color mapping can be used to identify separate muscle areas. See Figure 136 where each channel's stimuli have their channel-specific colors (green for thumb and yellow for leg).



**Fig. 136.** Channel-color mapping



## 8 Maintenance and care

This chapter describes the maintenance and care tasks of the Nexstim NBS System.



### WARNING:

Never use broken equipment. Otherwise, there is a risk of getting an electric shock.

Only persons authorized by Nexstim are allowed to service the Nexstim NBS System.

---



### PRECAUTION:

For safe and reliable operation of the system, perform regular maintenance and care according to the instructions in this chapter.

In addition, Nexstim recommends performing technical maintenance every 12 months. The technical maintenance requires trained service personnel and appropriate testing tools and equipment. Detailed instructions are described in *Nexstim NBS System Service Manual* (available upon request).

Do not use the Nexstim NBS System if any of the safety checks fail.

Check all electrical and mechanical assemblies and parts of the Nexstim NBS System regularly, and use the system with care.

If you notice degrading, please contact your local Nexstim representative or Nexstim technical support immediately.

Handle the Nexstim NBS System with care also when transporting. The device must not be subject to strong impulses, forces, or vibration, as they may damage the system. Failure to follow the transportation precautions may cause the breaking of the system.

---

In order to keep your Nexstim NBS System in good condition, take the following preventive maintenance tasks into consideration:

- Check the coil connector and pins every time you plug in and unplug the stimulation coil. Check the coil connector and its pins, as well as the stimulator socket for any signs of damage every time you plug in and unplug the stimulation coil. Also visually check the stimulation coil casing and cable for scratches, cracks, or other signs of wear.
- Before every use, visually check the markers for scratches, grease marks, or other signs of wear. Avoid touching the markers, because the retro-reflecting coating wears off easily. If the coating wears off, the marker can no longer be used.
- Store the coils on a safe and steady place to prevent them from falling and breaking.

## 8.1 Cleaning

Wipe all patient-contacting surfaces of the NBS System components immediately following each patient use with a clean cloth moistened with a commercially available water-based cleaning agent and allow to air dry. Do not use abrasive, corrosive cleaning agents or solvents. Do not sterilize any component.

### 8.1.1 Cleaning the tracking system

Cleaning of the tracking system should be kept to the minimum. If cleaning is needed, it should be done very carefully due to the sensitivity of the system.

**PRECAUTION:**

Do not use alcohol, thinners, or other chemical solvents to clean the tracking system. They may damage the finish or remove the panel lettering.

Do not use aerosol sprays near the tracking system as the sprays may damage circuitry.

Do not use any paper products or fluids like water, soap, or detergent on the tracking system lens.

Always dust the tracking system lens as much as possible before cleaning. Particles trapped under a cleaning tissue may scratch the lens.

---

1. Turn the tracking system off before cleaning.
2. Dust the lenses. Use one of the following items:
  - clean and dry compressed air (or nitrogen if available),
  - an aerosol duster,
  - or a photographic lens duster (brush).

Use an optical grade tissue to clean the lenses. Never touch a lens with anything except the cleaning materials mentioned here.

3. Remove dust from the localization unit surface with a dry soft cloth.

## 8.2 Checking the stimulation coil pins

---



### PRECAUTION:

Never use a coil on a stimulator with burnt socket pins; otherwise the coil will have its pins damaged immediately. Also, a socket with good pins that has a coil with burnt pins connected to it will have its pins damaged immediately.

If you notice burn damage on a coil connector or stimulator coil socket, do not use the complete system until all pins and sockets are carefully examined for any damage. If any contacts show damage, no matter how slight, they will need to be changed. If this is not done immediately, there is serious risk that the cycle of contact damage will continue. Please contact Nexstim for contact replacement.

---

Carefully check the stimulator coil pin on a regular basis for any signs for pitting or burning. Under conditions of exceptionally hard use of high energy levels, it is possible for the localized heating to manifest itself in the form of micro-welds. Continued use in this condition will eventually result in the coil pins/sockets becoming totally eroded and open circuit.

## 8.3 Changing the marker spheres

---



### PRECAUTION:

Do not apply excessive force on the trackers when changing the markers. Bending or twisting of the trackers may reduce the accuracy of measurements and tracker usability.

Verify that markers are pressed right to the bottom.

---

1. Wash your hands, or wear disposable plastic or other clean gloves.
2. Hold the tracker with one hand on a solid surface (such as a table). With the other hand, firmly squeeze the marker and pull straight up. (See Figure 137.)

When changing the markers of the adjustable head tracker, hold the tracker from the transparent marker frame only.



**Fig. 137.** Changing markers

3. Ensure that the tenons are tight by rotating the marker sphere shades.

---

**NOTE:**

Be careful not to turn the tenons too tight. Otherwise the threads may be damaged.

---

4. Push the new marker in place. The marker should snap in place.

Be careful not to rub the marker too much. The retro-reflecting coating is easily rubbed off from the marker surface.

## 9 Troubleshooting

This chapter describes the possible error situations you might encounter when using the Nexstim NBS System. If the error situation is not listed here, please contact your local Nexstim representative or Nexstim technical support (support@nexstim.com).

### 9.1 NBS does not recognize Nexstim TMS II

**Situation:** The TMS II status remains “Disconnected”, even though TMS II is powered on and the coil is connected to the stimulator.

**Solution:**

1. Check that the USB cable is properly connected.
2. If the cable connection is OK, turn off TMS II and unplug the USB cable of the stimulator.
3. Plug the USB cable back into TMS II.
4. Turn on TMS II.
5. The state should now be “Ready”. If the status is still “Disconnected”, restart the NBS software.

### 9.2 NBS application is slow

**Situation:** You are working on subject data, and it looks like the computer is doing nothing.

**Solution:** Follow the instructions below:

1. Wait for the NBS application to finish the task. The computer system handles a large amount of data, so the application may seem slow at times.
2. Try to keep the sizes of the sessions as small as possible.
3. Decrease the amount of visible 3D objects. The fewer the visible objects, the better the NBS performance.

---

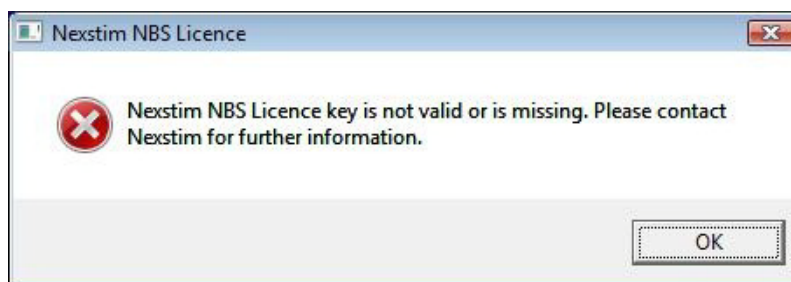
**NOTE:**

We recommend restarting the NBS computer once a day.

---

## 9.3 Lost license key

**Situation:** The NBS software license key is lost or missing, and Nexstim NBS software cannot be started (see Figure 138).

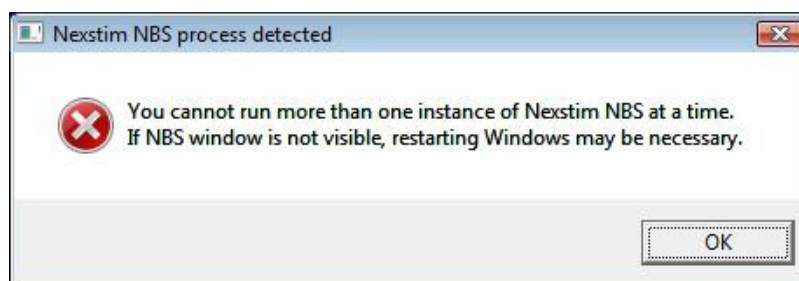


**Fig. 138.** Nexstim NBS licence key not valid or missing

**Solution:** Contact your local Nexstim representative or Nexstim technical support.

## 9.4 Duplicated NBS during startup

**Situation:** You have started the NBS computer and the following dialog appears:



**Fig. 139.** Duplicate process detected

**Solution:** There is a duplicate NBS process running on the computer. Wait for a while for the process to end. If this does not help, restart your computer and NBS software.

## 9.5 Red indicator light in the Nexstim TMS II front panel

**Situation:** The red indicator light in the front panel is on. It is on in the following cases:

- There is an error situation in the system.
- The stimulation coil has been unplugged when the yellow indicator light is on.

**Solution:**

1. Discontinue use.
2. Turn off TMS II.
3. If you unplugged the stimulation coil, plug it in.
4. Turn on TMS II.
5. If the Nexstim NBS software is running and the TMS II status is not “Ready”, restart NBS.
6. If the red indicator light in the front panel stays on despite system restart, check all connections and verify that the any of the cables are not broken.

## 9.6 The coil is overheated

**Situation:** The stimulator status is “COIL HOT” and the temperature turns red. You cannot use the stimulation coil because it does not deliver stimuli.

**Solution:**

1. Wait for the hot coil to cool down. Do not use any mechanical means to cool the coil (such as cold water or ice). Only cool air can be used to cool the coil (such as an air conditioning fan).  
OR
2. Stop the stimulus sequence and take another stimulation coil into use (if available).

**Solution (rTMS with NexSpeech):**

1. Wait for the hot coil to cool down. Do not use any mechanical means to cool the coil (such as cold water or ice). Only cool air can be used to cool the coil (such as an air conditioning fan).  
OR
2. When rTMS sequence is paused and the yellow warning LED in TMS II is **not on**, you can replace the coil with a coil of the same type. Then you can continue the sequence.

## 9.7 Stimulation coil is old

**Situation 1:** A warning dialog with the following text is displayed: *“The coil that is used is approaching the end of its safe working life. See the Settings tab for the details.”*

**Solution 1:** The coil is soon to be replaced.

**Situation 2:** A warning dialog with the following text is displayed: *“Coil Old. Please use different coil.”* The TMS II status is “Coil Old”.

**Solution 2:** Replace the coil.

## 9.8 Nexstim TMS II delivers no pulse

**Situation:** TMS II Stimulator delivers no pulse when you try to stimulate.

**Solution:** Consult the following checklist:

1. If you cannot open the **Single pulse stimulation** -dialog, or start a rTMS sequence or MT determination, and the TMS II status is:
  - a) “Disconnected”: Connect the TMS II. If this does not solve the problem, refer to instructions in Chapter 9.1 “NBS does not recognize Nexstim TMS II”.
  - b) “Error”: See Chapter 9.5 “Red indicator light in the Nexstim TMS II front panel”.
  - c) “No Coil”: Plug in the stimulation coil.
  - d) “Coil Hot”: See Chapter 9.6 “The coil is overheated”.
  - e) “Stimulator Hot”: See Chapter 9.5 “Red indicator light in the Nexstim TMS II front panel”.
  - f) “Coil Not Ready”: Wait for the coil to be initialized.
  - g) “Coil Old”: See Chapter 9.7 “Stimulation coil is old”.
2. If you are using navigated stimulation and the TMS II status is “Charged” or “Charged (On Hold)”:
  - Check that the tracking system can see the trackers.
  - If you are using Location controlled stimulation, Aiming Tool is not correctly positioned.
3. Restart NBS.



## 9.9 Tracking system does not see the tracker

**Situation:** The NBS application does not display the tracking tool and the LED of the stimulation coil, digitizing pen, and/or the head tracker is not green in the **Navigation**-tab.

**Solution:** In most cases, the problem is with the tracker. Consult the checklist below:

- Check that nothing is between the tracking system and the tracker.
- Check that other trackers are not visible. Make sure that other coil trackers, for example, do not interfere with the tracking system.
- Check your tracker use. Are you pointing the tracker towards the tracking system unit? Are you positioning two trackers so that no markers cover other markers?
- Check the tracker. Is it clean? Is it straight?
- Check the markers. Replace worn out markers.
- Check the software settings. Are the settings in order? Is the selected head tracker correct?
- Check the lighting. Is a bright light interfering with the tracking system?
- Check the air conditioning. Is ventilation interfering with the tracking system?
- The tracking system is based upon optics, and requires a clear line-of-sight to the markers. Anything that interferes with the clear line-of-sight can reduce the accuracy of the measurements.





The tracking system should try to correct the error situation automatically.

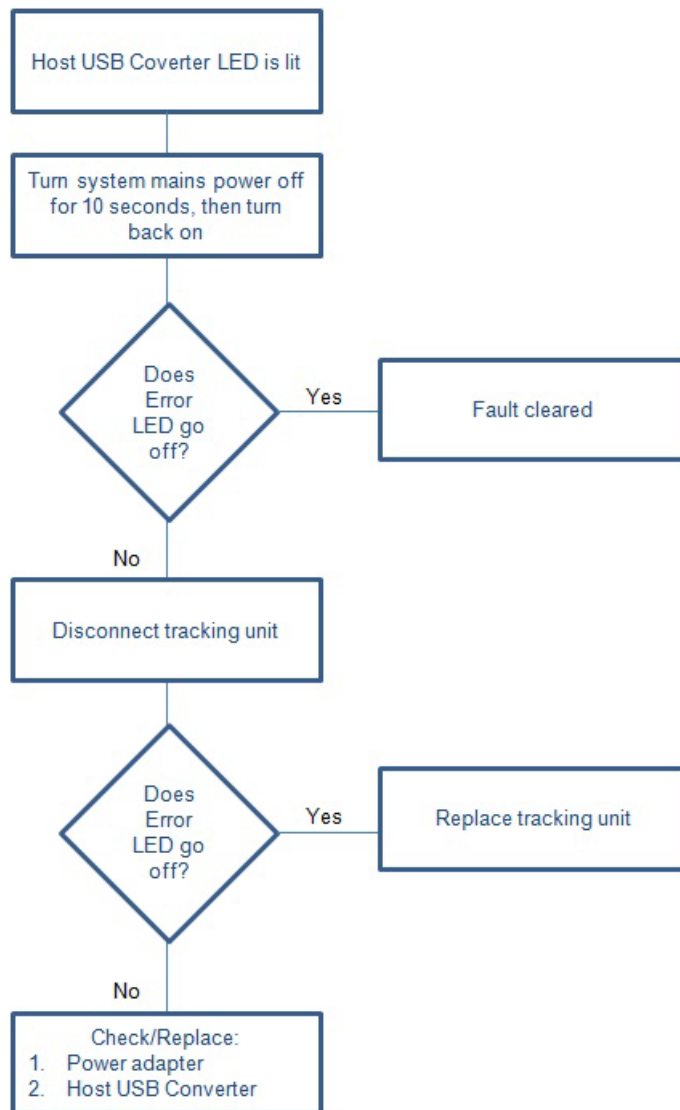
Only in rare cases you need to change the settings of the tracking system. Consult your local Nexstim representative or Nexstim technical support before doing so.

## 9.10 Polaris tracking unit troubleshooting

The LED indicators on the tracking unit and Host USB Converter provide a visual indication of the tracking system status. In addition, the tracking unit emits audio tones that provide an audible indication of the system status. These are described in Table 39 and Figure 140.

Table 39 Polaris tracking system indicator LEDs and audio codes

Indication	Meaning	Action
Power LED is off 	Tracking unit voltage out of range	1. Refer to Figure 140. If necessary, proceed to Step 2. 2. Check for green Power LED on Host USB Converter. If lit, check/replace the tracking unit. If not lit, check/replace the power adapter, cables and Host USB Converter.
Power LED is flashing 	Normal indication during warm-up.	No action required.
Error LED is flashing 	A recoverable system fault has been detected.	Contact your local Nexstim representative or Nexstim technical support.
Error LED is lit 	A non-recoverable system fault has been detected.	Contact your local Nexstim representative or Nexstim technical support.
Two beeps emitted	Normal indication when power is initially applied to the system or the system is reset.	No action required.
Two beeps emitted every three seconds.	Fault in the system.	Contact your local Nexstim representative or Nexstim technical support.
Error LED is lit in the Host USB Converter	A fault has been detected by the Host USB Converter.	Refer to Figure 140 for action.



**Fig. 140.** Host USB Converter error LED fault chart

Polaris Vicra is equipped with internal diagnostics. In case of a tracking unit fault, the NBS software will detect the problem and report the faults in a dialog (see Figure 141).

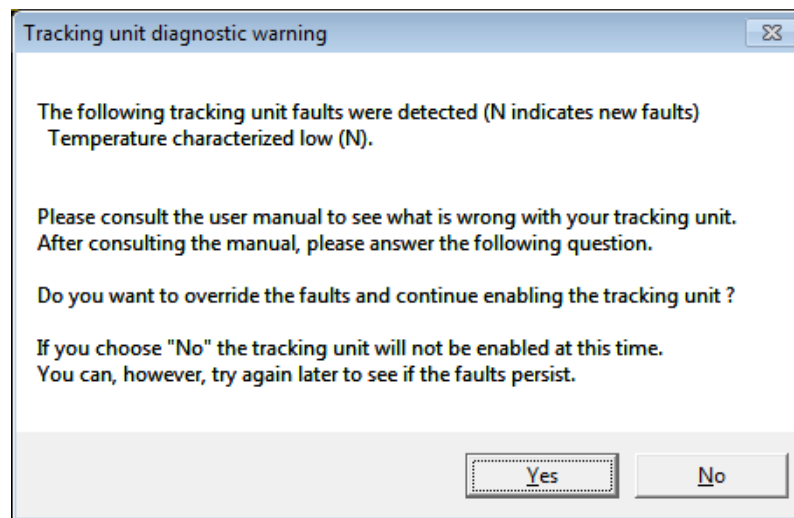


Fig. 141. Tracking unit diagnostic warning

If faults are detected, it is possible to turn off the tracking system and the software and re-start the system to see if the faults persist. In any case, check the functioning of NBS before proceeding with examinations. Contact your local Nexstim representative or Nexstim technical support always if in doubt.

---

**NOTE:**

In most cases the detected problem shown in Figure 141 is not actually a fault. It shows that the tracking unit is still in a warm-up phase (tracking unit's green indicator LED is flashing) and has not reached optimal operating temperature. The warm-up phase may take several minutes. After the warm-up the green indicator LED stops flashing and the system is ready for use.

---

## 9.11 Nexstim cooling unit troubleshooting

**Situation:** The cooling unit does not start.

**Solution:** Check the following:

- You have Nexstim Cooled Coil connected to the cooling unit.
- A stimulation sequence is on in NBS.
- The cable between TMS II and cooling unit is properly connected.
- The cooling unit power cable is connected to the isolation transformer.
- Check the air hoses.

## 9.12 Registration problems

**Situation:** Head registration or advanced registration fails to complete properly.

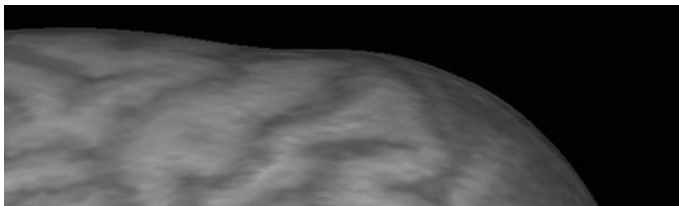
**Solution:**

- For instructions on how to perform registration, refer to Chapter 6.8 “Performing registration” on page 92.
- Check the trackers and markers.
- Make sure that MR images are of good quality.
- Make sure that the landmark areas (nasion and preauricular points) are clearly visible in the MR images.
- Make sure that the 3D head image corresponds to the subject’s physical head as closely as possible. A poor 3D image can be caused, for example, by poor MR image quality or wrinkles in the patient’s scalp (from a headrest, for example).
- Try to perform the registration several times. It is very important to perform the registration very carefully and accurately.

## 9.13 Targeting to a specific stimulation target is not possible

**Situation:** You are not able to target the stimulus to a specific stimulation target.

**Solution:** Due to bad-quality MR images, there are wrinkles and skin folds on the 3D head surface. Your stimulation target is on a groove, and the coil does not recognize the maximum stimulating field.



**Fig. 142.** Example of a groove in the 3D head

It is very important that the 3D head appears smooth and is of good quality. Make sure that there are no wrinkles or skin folds on the patient’s scalp (due to a headrest, for example) during the MR imaging or during stimulation. If there is a discrepancy in the patient’s head surface between the MR imaging and NBS head registration, there will be inaccuracies in TMS stimulation. For more information, refer to “Examples of the 3D head quality” on page 88.

## 9.14 Electric field is not visible

**Situation:** You cannot see the stimuli's electric field when browsing the stimuli in the session tree.

**Solution:**

- Close the active stimulus sequence. During the active stimulus sequence the real-time electric field is shown. In all other situations the display of the stimuli's electric field is possible.
- The electric field is set totally transparent.
- Stimuli are created without navigation and have no electric field information.
- Multiple stimuli have been selected.

## 9.15 EMG is not activated

### 9.15.1 EMG is not activated on start-up

**Situation:** EMG is not activated on start-up. The **Connect**-button in the **Stimulation > EMG**-tab is enabled, but clicking the button does not establish the connection to EMG.

**Solution:**

1. Turn off the EMG power switch.
2. Unplug the USB cable.
3. Check that the connection cable is properly attached to the EMG amplifier.
4. Plug in the USB cable and turn on the EMG power unit.

When the EMG power unit is running properly, the green light in the power switch is on.

### 9.15.2 Calibration fail

**Situation:** When connecting the EMG device to the Nexstim NBS, the **Calibration fail** -dialog appear, saying that the EMG device test failed.

**Solution:** The EMG device is self-testing amplitudes. The dialog appears when the amplitude range is too wide. Wait for few minutes for the EMG device to warm up, and try again.

### 9.15.3 EMG connection failed

**Situation:** During measurement, the EMG connection fails and the following notification appears:

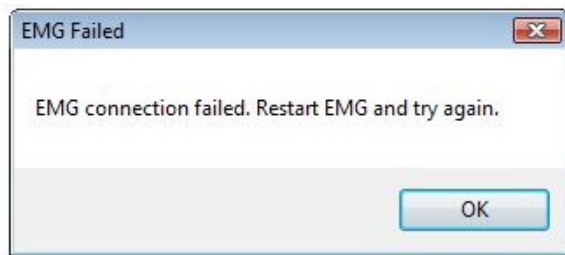


Fig. 143. EMG Failed -dialog

**Solution:**

1. Turn off the EMG power switch.
2. Unplug the USB cable.
3. Check that the connection cable is properly attached to the EMG amplifier.
4. Plug in the USB cable and turn on the EMG power unit.

When the EMG power unit is running properly, the green LED on the front panel is on.

## 9.16 Inaccurate/no measurement in the EMG display

**Situation:** There is inaccurate or no measurement data in the EMG display. The noise level should be well below 50  $\mu$ V.

**Solution:** Consult the checklist below:

- Let the electrodes settle for a good skin contact.
- Electrodes are improperly attached. Make sure that all EMG electrodes are properly attached (see instructions in Chapter “Attaching EMG electrodes” on page 39). If necessary, reconnect the EMG electrodes for better contact.
- Make sure that you do not have two EMG electrodes of the same channel attached to a single muscle. This would give inaccurate measurement data in the EMG display.
- Check that the EMG electrode wires are untangled.
- Remove unnecessary electronic devices from the vicinity of the EMG device, since they might cause interference by emitting electromagnetic radiation.
- Check that you are using the correct EMG channel.
- Have you turned the EMG measurement on? Click **Start EMG**.
- Check that the EMG status is “Measuring” or “Recording”.
- Check that **Hold** is turned off, that is, the button label is **Hold**. If Hold is on, the button label is **Release** and the continuous view of the EMG display is frozen.

- Errors in EMG data can be caused by tension of the muscle, resulting in noise on the EMG channel (see Figure 144). Advise the patient to relax his or her muscles before stimulating.

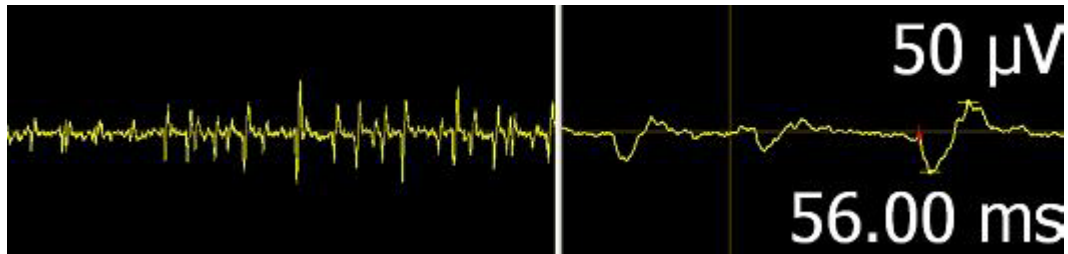


Fig. 144. EMG noise caused by muscle tension

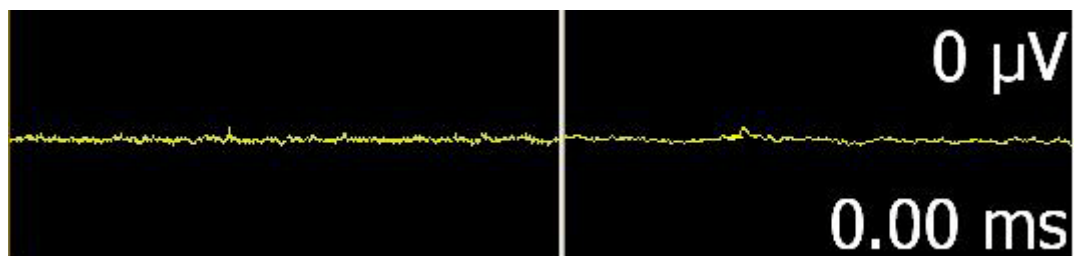


Fig. 145. Good quality EMG data

## 9.17 Inactive buttons in Single pulse stimulation -tab

**Situation:** The **New Sequence** -button and the stimulus interval controls are disabled even though you have an open exam.

**Solution:** Close the current exam and then re-open the exam.

**Situation:** The **New exam** -button is disabled in the **Single pulse** -tab.

**Solution:** Check that you do not have a digitization exam open.

## 9.18 Motor Threshold determination errors

### 9.18.1 Start-button in the Motor Threshold starting -dialog is inactive

**Situation:** The **Start**-button in the **Motor Threshold starting** -dialog is disabled, and the MT determination cannot be started.

**Solution:** The following dialog shows the error situations and the required actions.



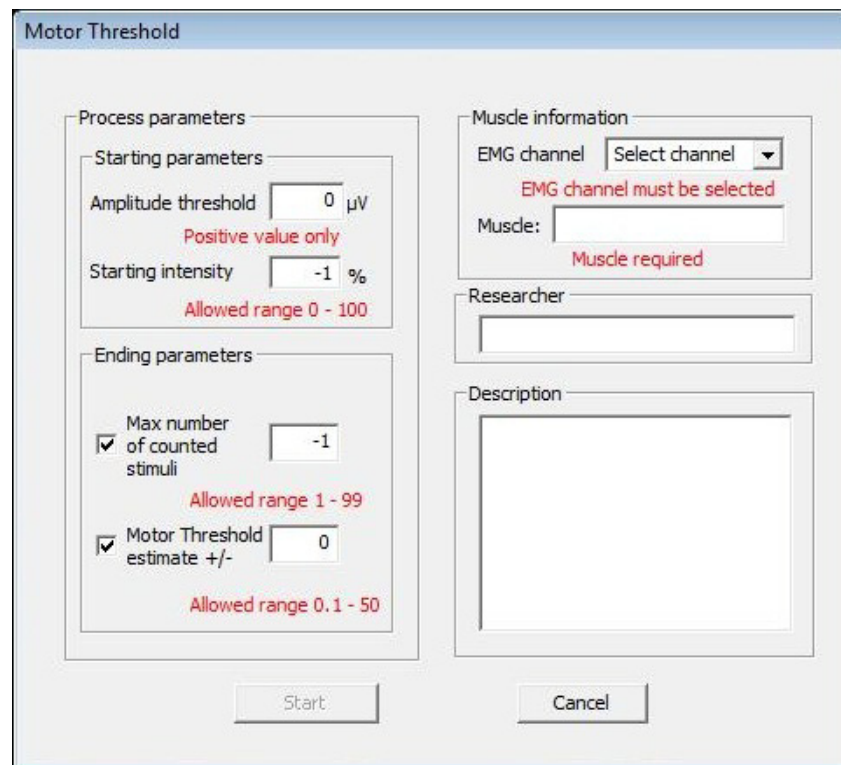


Fig. 146. Situations when starting the Motor Threshold determination is disabled

### 9.18.2 MT determination process could not be started

**Situation:** Dialog “*Motor Threshold error: Motor Threshold determination process could not be started*” appears before the **Motor Threshold starting** -dialog.

**Solution:** Check that the following prerequisites are fulfilled:

- You have performed and completed registration.
- EMG is connected and EMG measurement has been started.
- At least one EMG channel is in use to follow the target muscle.
- TMS II is on, and its status is “Ready”.
- You have started from a navigated stimulus.
- There are no active digitization or analysis exams.
- There are no active stimulation sequences.

### 9.18.3 MT determination process is interrupted

**Situation:** An error occurs during the MT determination process and the process is interrupted. An error dialog is displayed.

Possible error situations may be:

- Drawing the session tree failed.
- Motor Threshold Exam or Sequence could not be created.
- Saving information failed.
- Problems with stimulator, EMG, tracking unit, coils etc.

**Solution:** Try one of the following:

- Restart the MT determination process.
- Restart TMS II.
- Restart NBS.

## 9.19 DICOM export errors

Failure in the DICOM export generation can result from different reasons. The error messages and solutions are listed in the following:

### 9.19.1 DICOM export failed -dialog appears

**Situation:** DICOM export failed -dialog appears.

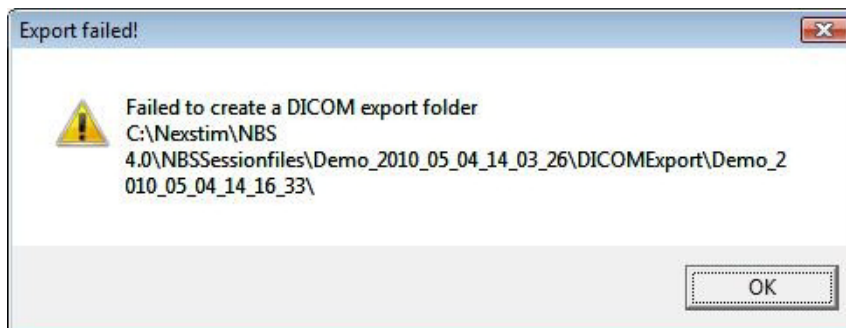


Fig. 147. DICOM export failed

**Solution:**

- Check that there is enough available hard disk drive space.
- Check the writing permissions for the directory.

### 9.19.2 Original MR image not in DICOM format

**Situation:** If the original anatomical MR image (that is, the image that has been used to create the session) is not a DICOM format MRI stack, a warning dialog is displayed.

- If the original anatomical MR image is in Analyze format, export cannot be done. In this case a warning dialog with text “*Image export is not allowed for Analyze format image. Export will not be created.*” is shown.
- If the original anatomical image is in NIfTI format, export cannot be done. In this case a warning dialog with text “*Image export is not allowed for Nifti format image. Export will not be created.*” is shown.

**Solution:** Use the DICOM format of the original MR image.

### 9.19.3 Text export fails

**Situation:** If the text export fails, a dialog with text “*Failed to create an ASCII export file to folder XX*” is displayed.

**Solution:** Check that there is enough available hard disk drive space. Check the writing permissions for the directory.

### 9.19.4 MRI landmarks missing

**Situation:** If there are landmarks missing, the following dialog is displayed (Figure 148):

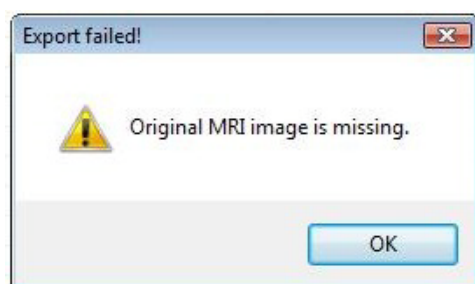


**Fig. 148.** MRI landmarks are missing

**Solution:** Perform registration. For instructions, see Chapter 6.8 “Performing registration” on page 92.

### 9.19.5 Original MR image missing

**Situation:** If the original MR image is missing, the following dialog is shown (Figure 149):



**Fig. 149.** Original MRI image missing

**Solution:** Load the MR images into NBS. For instructions, see Chapter “Loading MR images for the use of Nexstim NBS” on page 85.

### 9.19.6 Loading the meta data dictionary fails

**Situation:** A dialog with text “*Loading the meta data dictionary failed*” is displayed.

**Solution:**

- Check that there is enough RAM memory available.
- Close all other applications.
- Restart NBS and try again.

# Appendix A: Technical specifications

This chapter lists the technical specifications for Nexstim NBS System.

## A.1 Nexstim NBS System

Table 40 Nexstim NBS System operating environment

Operating site dimensions (minimum)	Length: 4 m (157.5 in), Width: 3 m (118.1 in), Height: 2.3 m (90.6 in)
Operating temperature	15°C to 30°C (59°F to 86°F)
Relative humidity	30% to 75% non-condensing
Operating atmospheric pressure	80 kPa - 106 kPa

Table 41 Nexstim NBS System transportation and storage specifications

Transportation tilt	< 15°
Storage temperature	0°C to 45°C (32°F to 113°F)
Relative humidity	20% to 80%, non-condensing
Storage atmospheric pressure	50 kPa - 106 kPa

Table 42 Regulatory compliance of the Nexstim NBS System

Certification	<ul style="list-style-type: none"> <li>• MDD-directive 93/42/EEC</li> <li>• IEC 60601-1 (General Requirements for Safety)</li> <li>• IEC 60601-1-1 (System)</li> <li>• IEC 60601-1-2 (EMC)</li> <li>• IEC 60601-1-6 (Usability)</li> </ul>
Mode of operation	Continuous
Applied part	Type BF
Electrical classification	Class I
IP classification	IPX0, Foot switch IPX8
MDD classification	IIa
Compatibility	DICOM conformance statement available

Table 43 Nexstim NBS System electrical specifications

NBS System power supply	<ul style="list-style-type: none"> <li>• 220-240 V~, 50/60 Hz, 1000 VA 1-phase</li> <li>• 110-120 V~, 50/60 Hz, 1000 VA 1-phase</li> <li>• 100-110 V~, 50/60 Hz, 1000 VA 1-phase</li> </ul>
Mains connection	The computer, computer displays, tracking system, EMG unit and cooling unit are supplied via the isolation transformer provided with the Nexstim NBS System.

## Disposal and recycling



Nexstim NBS System has been designed in accordance with the Waste Electrical and Electronic Equipment (WEEE) Directive, which aims to minimize the impact of electrical and electronic goods on the environment.

Follow the waste management methods in compliance with the local regulations.

## A.2 NBS cart

Table 44 NBS cart

Floor footprint	80 cm x 70 cm (31.5 in x 27.6 in)
Total weight (when the complete NBS System installed)	~250 kg (~551 lb)

## A.3 Nexstim TMS II Stimulator

Table 45 Nexstim TMS II Stimulator

Dimensions	Height: 40 cm (15.7 in), Width: 32.2 cm (12.7 in), Depth: 47.5 cm (18.7 in)
Weight	~40 kg (~88 lb)

Table 46 Nexstim TMS II electrical specifications


Power supply	110-120/200-240 V~, 50/60 Hz, 2000 VA (1-phase)  <b>NOTE:</b> When 220-240 V~ model is used in the United States, it has to be connected to a 240 V~ center-tapped mains supply.
Standby power consumption	400 VA

Table 47 Nexstim TMS II stimulation control and delivery

Output	Can be changed in 1% steps
Coil type recognition	Automatic
Intensity error	< $\pm 1\%$ $\pm 10$ V

Table 48 Nexstim TMS II EMG output specifications

Pulse width	500 $\mu$ s
Pulse timing	100 $\mu$ s before the stimulus pulse
Pulse amplitude	5 V TTL

Table 48 Nexstim TMS II EMG output specifications

Output impedance	1500 $\Omega$
Polarity	Positive

Table 49 Single pulse stimulation mode

Pulse shape	Biphasic
Inter-stimulus interval	Single-pulse sequences selectable from 1 - 10 s in increments of 0.1 s. (With EMG, 1.5 - 10 s.)

Table 50 rTMS stimulation mode (with NexSpeech only)

Pulse shape	Biphasic
Burst stimulation	<ul style="list-style-type: none"> <li>• Number of pulses in a burst selectable from 1-9999</li> <li>• Pulse repetition rate of pulses in a burst selectable from 0.1-10 Hz, in increments of 0.1 Hz</li> <li>• Burst length selectable from 0.02 s - 120 min</li> </ul>
Burst train stimulation	<ul style="list-style-type: none"> <li>• Number of bursts in a burst train selectable from 1-999</li> <li>• Burst train length selectable from 0.02 s - 120 min.</li> </ul>
Burst train sequence stimulation	<ul style="list-style-type: none"> <li>• Number of burst trains in a burst train sequence selectable from 1-999</li> <li>• Burst train sequence length selectable from 0.02 s - 120 min.</li> </ul>
E-field stability (temperature-dependent)	$\pm 1.5\%$ in rTMS

## A.4 Stimulation coils

The following table describes the Nexstim Focal Coil and Cooled Coil specifications.

Table 51 Nexstim Focal Coil and Cooled Coil specifications

Weight	$\sim 1$ kg ( $\sim 4$ kg with coil cable) ( $\sim 2.2$ lb ( $\sim 8.8$ lb with coil cable))
Coil type	Figure-8-shaped, integrated cable
Overheating protection	Automatic
Navigation	Integrated Nexstim NBS trackers
Handle	Upward position, facilitates E-field positioning
Voice pressure	$< 105$ dB (20 cm (7.9 in) from the bottom surface of the coil)
Maximum electric field strength	172 V/m $\pm 2\%$ Measured 25 mm (0.1 in) below the coil in spherical conductor model representing the human head. Acceptance criterion in production is $\pm 2\%$ .
Maximum stimulator output	$\sim 2.5 \times$ MT of hand muscle (healthy adult, Nexstim Focal Coil) MT of hand muscle (healthy adult) is about 40% of the maximum stimulator output.

Table 51 Nexstim Focal Coil and Cooled Coil specifications

Pulse length	230 $\mu$ s
Lifetime	Up to 2 million pulses or 2 years from date of manufacture (software-controlled)

Table 52 Heating limit values of Nexstim stimulation coils

<b>Minimum - typical at 23°C / 73.4°F ambient temperature</b>	
Nexstim Focal Coil	1550 - 1900 pulses at 1 Hz (40% stimulator intensity) > 10 000 pulses (typical coil) at 0.5 Hz (40% stimulator intensity) 300 - 400 pulses at 1 Hz (80% stimulator intensity)
Nexstim Cooled Coil	> 3000 pulses at 1.3 Hz (60% stimulator intensity) (equals to 37 min)

## A.5 Nexstim cooling unit

Table 53 Nexstim cooling unit for Nexstim Cooled Coil

Dimensions	Height: 25 cm (9.8 in), Width: 22 cm (8.7 in), Length: 47 cm (18.5 in)	
Power supply	220-240 V~, 50 Hz, 280 VA	110-120 V~, 50/60 Hz, 280 VA

## A.6 Isolation transformer

Table 54 Isolation transformer

Maximum output power	1000 VA
Input voltage	115/230 V, 50/60 Hz
Compliance	<ul style="list-style-type: none"> <li>• IEC 60601-1</li> <li>• CE-marked according to MDD</li> </ul>



## A.7 NBS computer

Table 55 Computer and displays

Computer	<ul style="list-style-type: none"> <li>• DELL PC</li> <li>• Windows Vista operating system</li> <li>• Intel Xeon W3530</li> <li>• 2.80 GHz</li> <li>• 4 GB RAM</li> <li>• 320 GB hard disk</li> </ul>
Displays	<ul style="list-style-type: none"> <li>• DELL 20" LCD panel, resolution 1600 x 1200</li> </ul>
Compliance	<ul style="list-style-type: none"> <li>• EN60950</li> <li>• CE-marked according to EMC and LVC directives</li> </ul>

## A.8 Polaris tracking system

The specifications for Polaris Vicra tracking system are specified in the following table.

Table 56 Polaris Vicra tracking systems

Tracking unit dimensions	27.3 x 6.9 x 6.9 cm (10.7 x 2.7 x 2.7 in)
Tracking unit weight	< 1 kg (< 2.2 lb)
Refresh rate	Max. 20 Hz
	With real-time electric field visualization $\geq 10$ Hz (with computer meeting the requirements given in Table 55.)
Input voltage	26 VDC
Power consumption	~ 13.5 W
Coil tracker	Four elements with three markers in each
Digitizing pen tracker	Y-shaped, with three markers
Head tracker	Adjustable head tracker with four markers (from which three best visible are selected in localization).
Marker accuracy	Unit accuracy for one marker is 0.25 mm.
Tracking system accuracy <sup>a</sup>	Acceptance criterion for coil tracker accuracy measurement limit values in production are $\pm 2$ mm (3D rms error) and $\pm 2^\circ$ .
Distance	The optimal distance between the camera and the head tracker is 80 cm (31.5 in).
Measurement volume <sup>b</sup>	Equipped with Pyramid Volume as illustrated in Figure 150.
Compliance	<ul style="list-style-type: none"> <li>• UL:E215449</li> <li>• UltraTech: NDI066-EN601-1-2</li> </ul>

a. Accuracy of the recorded coil with respect to the head tracker and the head. This includes the 3D infrared position sensor unit inaccuracy, as well as the coil tracker elements, digitizing pen, and head tracker tool design inaccuracy.

b. The area in which the tool is tracked.

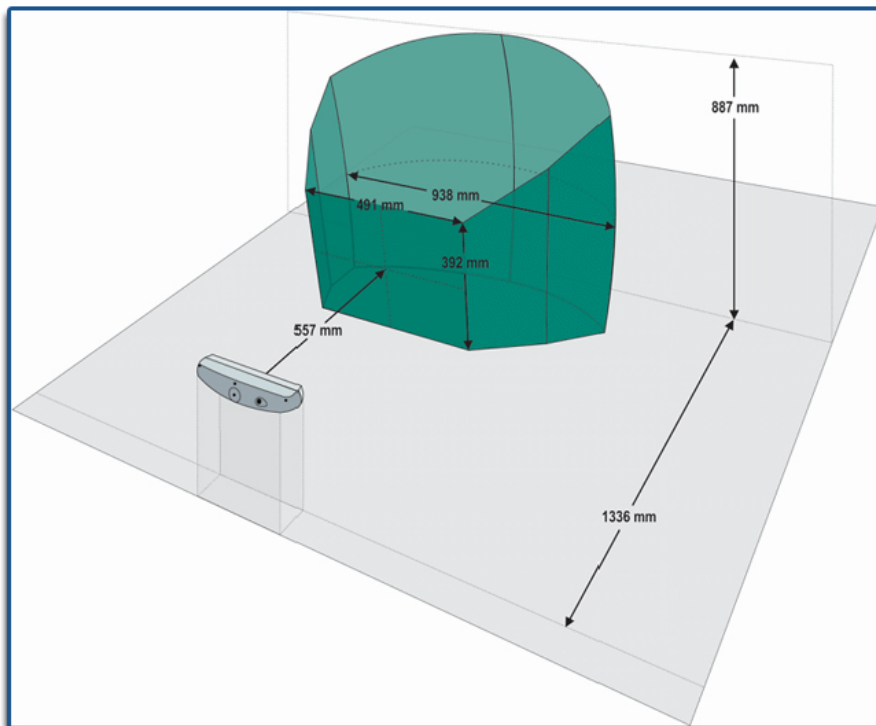


Fig. 150. Polaris Vicra measurement volume (image source www.ndigital.com)

## A.9 Foot switch

Table 57 Foot switch

Type	Three-pedal foot switch
Model	MKF 3 1S USB MED GP33
IP classification	IPX8 (IEC 60529)
Mechanical lifetime	Over 1 million switching cycles
Compliance	<ul style="list-style-type: none"> <li>• IEC 60601-1</li> <li>• UL 60601-1</li> <li>• 93/42/EEC (MDD)</li> </ul>

## A.10 Nexstim EMG

Table 58 Nexstim EMG system specifications

Dimensions	<b>EMG amplifier:</b> <ul style="list-style-type: none"> <li>• Height: 6.2 cm (2.4 in)</li> <li>• Width: 17 cm (6.7 in)</li> <li>• Depth: 19.8 cm (7.8 in)</li> <li>• Weight: 620 g (1.4 lb)</li> </ul>	<b>EMG power unit:</b> <ul style="list-style-type: none"> <li>• Height: 4.8 cm (1.9 in)</li> <li>• Width: 22 cm (8.7 in)</li> <li>• Depth: 19.3 cm (7.6 in)</li> <li>• Weight: 2150 g (4.7 lb) (with connection cable)</li> </ul>
Channels	6 bipolar amplifier channels	
Sampling frequency	3 kHz / channel	
Resolution	EMG 0.3 $\mu$ V	
Scale	EMG -7.5 mV to 7.5 mV	
CMRR	> 90 dB at frequencies between 10 - 250 Hz	
Noise	< 5 $\mu$ V peak-to-peak	
Frequency band	10 - 500 Hz	
Nexstim TMS II compatibility	TMS gating circuitry for TMS artifact rejection	
Mains voltage	100 - 240 V~, 50/60 Hz	
Power consumption	33 VA	
Insulation class and type	Class 1, Type BF	
EMG electrode cable	Shielded, single-channel cable with 1.5 mm touch-proof female safety connectors (DIN 42-802)	
Recommended electrode type	Ambu® Neuroline 720 self-adhesive electrodes, model number 720 01-K.	

## A.11 Registration sticker

The registration stickers are silicone adhesives suitable for skin contact. The registration sticker dimensions are shown in Figure 151.

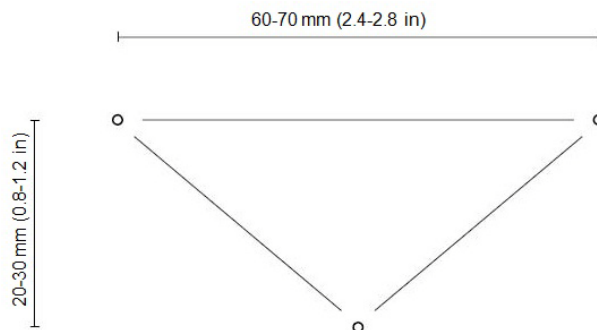


Fig. 151. Registration sticker dimensions

## A.12 Requirements for the external system

The following are the requirements for the external system, to which NBS results are transferred as DICOM files:

- Supports DICOM (2007) format
- Has functionality to load DICOM export as an overlay on top of the original MR DICOM image
- Aligns overlaid DICOM export with the original MR DICOM image according to the following DICOM properties:
  - Spacing Between Slices(0018,0088)
  - Pixel Spacing(0028,0030)
  - Image Orientation (Patient)(0020,0037)
  - Image Position Patient(0020,0032)
  - Slice Thickness(0018,0050)
  - Slice Location(0020,1041)
- Can visualize DICOM image which has the following DICOM properties (more detailed description is given in Document *Nexstim NBS DICOM Conformance Statement for DICOM Export*):
  - Samples Per Pixel(0028,0002)=1
  - Photometric Interpretation(0028,0004)=MONOCHROME2
  - Bits Allocated(0028,0100)=16
  - Bits Stored(0028,0101)=16
  - High bit(0028,0102)=15
  - Pixel Representation(0028,0103)=0
  - Smallest Image Pixel Value(0028,0106)=0
  - Largest Image Pixel Value(0028,0107)=32767
- Can visualize every color index from 0 to 32767 with heat color map without filtering out any of the color indexes.
- Can visualize every color index from 0 to 32767 image with rainbow color map (required for “Channel color of strongest response”) without filtering out any of the color indexes.

## Appendix B: Hardware connections

---



### WARNING:

Always supply power to Nexstim NBS System parts (excluding TMS II) from the isolation transformer provided with the system. Failure to do so may lead to excessive leakage currents and to a possible safety hazard.

Always supply power to the isolation transformer and TMS II from a grounded (protective earth) outlet that has its own phase and fuse. Never supply power to Nexstim TMS II from the same outlet with the Nexstim NBS System.

To avoid the risk of electric shock, Nexstim NBS System must only be connected to a supply mains with protective earth.

Before connecting or disconnecting anything, turn the powers off.

Labeled USB ports and connections are intended only for NBS connections.

Do not connect any other devices to any Nexstim NBS ports or connectors.

Do not use any cables from the Nexstim NBS System with any other equipment.

---



### PRECAUTION:

Do not connect anything to any of the Nexstim NBS System connectors or sockets other than parts described in this User Manual.

Use only cords or cables provided or approved by Nexstim. Using other accessories or spare parts may affect the EMC performance of the Nexstim NBS System.

Full isolation from supply mains can only be achieved by detaching the Nexstim NBS System 4 and Nexstim TMS II power cords from the wall socket outlets. Position the system so that detaching the cords is not prevented.

Grounding reliability can only be achieved when the equipment is connected to an equivalent receptable marked hospital only or hospital grade.

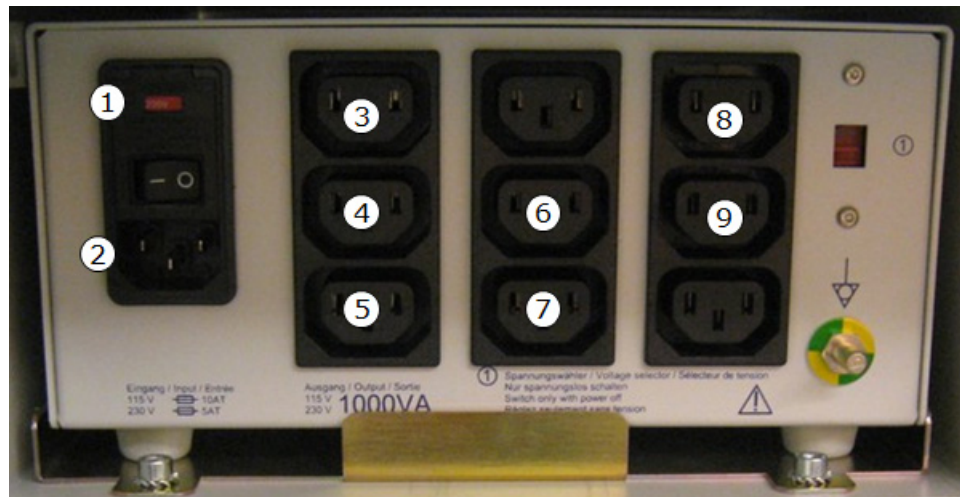
---

### NOTE:

Only Nexstim personnel, or persons authorized by Nexstim, may connect the device or anything to the device. An exception is Nexstim TMS II, to which you are allowed to connect and disconnect the BNC connectors.

---

## B.1 Isolation transformer connections



**Fig. 152.** Isolation transformer connections

1	Fuses
2	AC power inlet with main power switch
3	Outlet to Display 1
4	Outlet to Display 2
5	Outlet to Polaris power supply
6	Outlet to NexSpeech display (optional)
7	Outlet to cooling unit (optional)
8	Outlet to EMG power unit
9	Outlet to NBS computer



### WARNING:

The power cords from the isolation transformer outputs to the computer, display, and tracking system power supplies are provided by Nexstim. Use only these cords.

## B.2 Nexstim TMS II connections

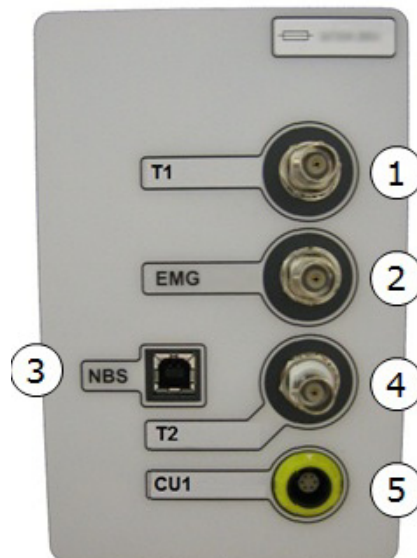


Fig. 153. Nexstim TMS II back panel connections

1	T1	Not in use. Do not connect.
2	EMG	For synchronizing the Nexstim EMG
3	NBS USB connection	Connection to Nexstim NBS
4	T2	Trig in connection for NexSpeech trig in cable (optional)
5	CU1	Connection to the cooling unit

## B.3 NBS computer connections



### WARNING:

All USB ports in the computer back panel are intended only for NBS use. Do not connect any other devices to these ports.

Do not change order of the USB connections. They must be identical to Figure 154.

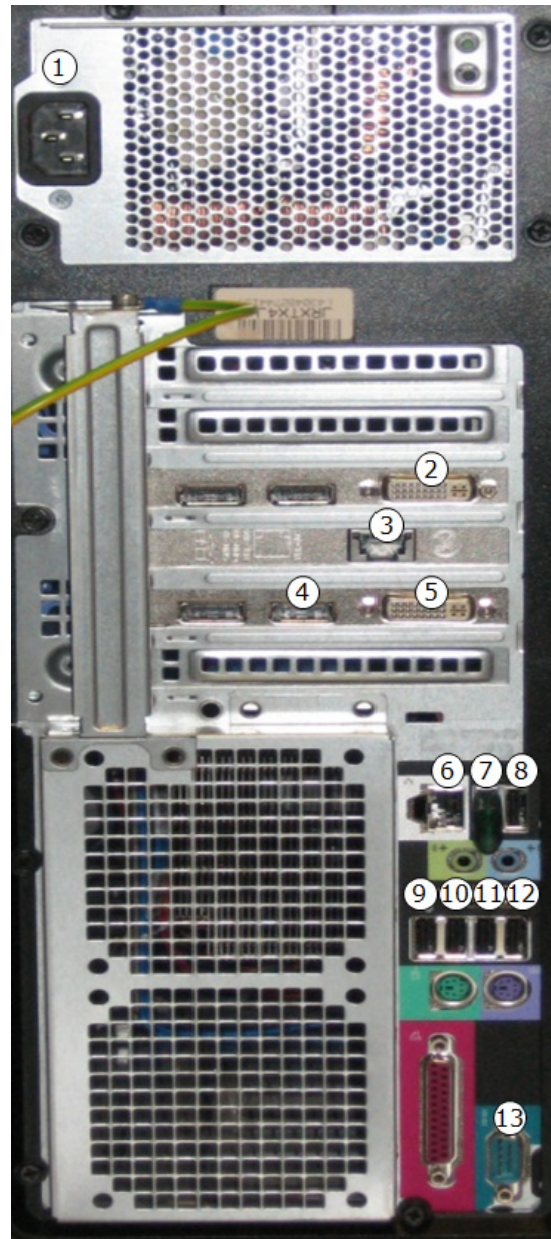


Fig. 154. Computer connections and I/O card connectors

1	Mains connection to isolation transformer
2	NexSpeech display connection (optional)
3	Connection to NexSpeech camera (optional)
4	Display 2 connection (use HDMI > DVI adapter)
5	Display 1 connection
6	Not in use, do not connect.



7	USB connector for NBS licence key (HASP)
8	USB connector for EMG power unit
9	USB connector for TMS Stimulator
10	USB connector for foot switch
11	USB connector for display USB hub
12	USB connector for Polaris tracking system
13	NexSpeech trig in cable connection (optional)

## B.4 Display connections

### NBS display connections

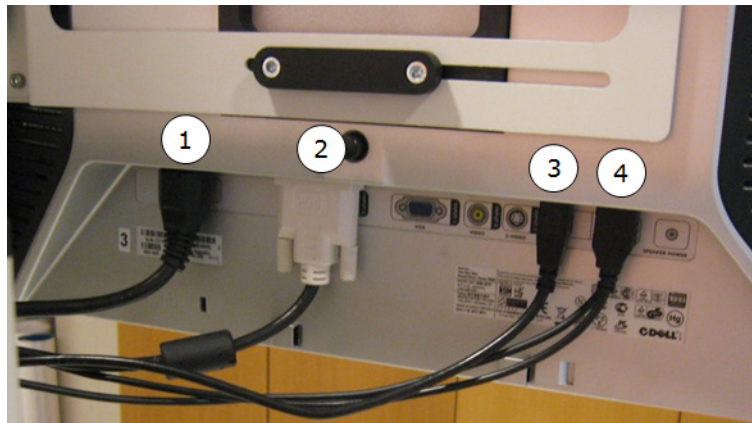


Fig. 155. Display connections

1	Mains connection to isolation transformer
2	DVI video connection to NBS computer's display connectors
3	USB hub connection to NBS computer
4	USB cables for mouse and keyboard

## EMG display connections

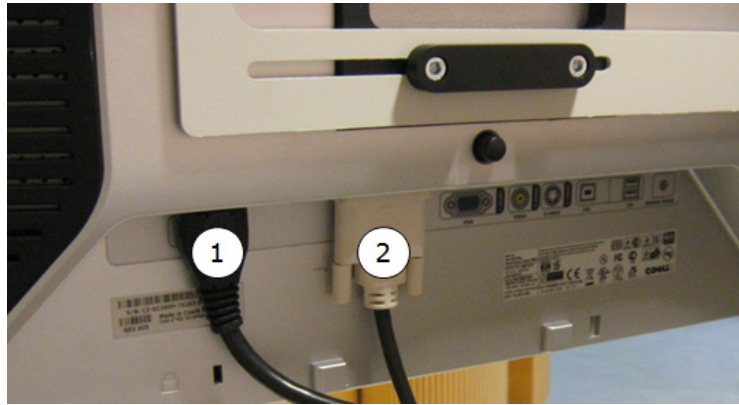


Fig. 156. EMG display connections

1	Mains connection to isolation transformer
2	DVI video connection

## B.5 Nexstim EMG connections

### EMG amplifier connections

The Nexstim EMG amplifier bottom panel has a connection for the cable between the amplifier and power unit. The amplifier top panel has EMG channel connections 1-6 for electrodes, and the grounding electrode connection labelled GND.



Fig. 157. Nexstim EMG amplifier top and bottom panels

1	Power LED indicator
2	EMG channels 1-6
3	Ground electrode connector
4	Connection to EMG power unit

### EMG power unit connections



Fig. 158. Nexstim EMG power unit connections

1	Fixed cable to EMG amplifier
2	USB connection to NBS computer
3	Gate In connection to TMS II EMG Out
4 -6	Not in use, do not connect.
7	Power cable

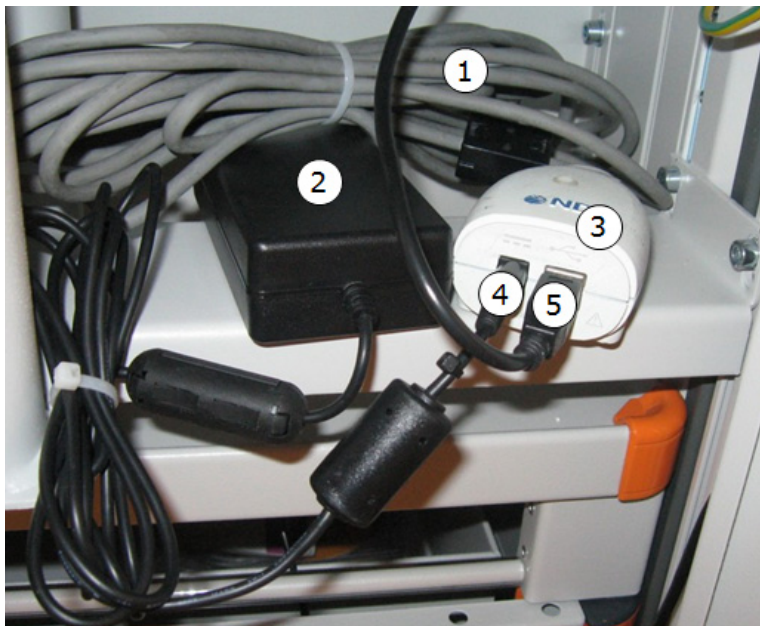
## B.6 Tracking system connections

Polaris Vicra connection to Polaris USB converter shown in Figure 160.



Fig. 159. Polaris Vicra connection

The USB converter is connected to tracking unit’s power supply and to the dedicated “Polaris” USB port via a USB cable.



**Fig. 160.** Host USB converter for Polaris tracking unit

1	Connection cable to Polaris Vicra
2	Polaris power supply
3	Polaris USB converter
4	Power cable from the power supply
5	USB connection to NBS computer

## B.7 Cooling unit connections

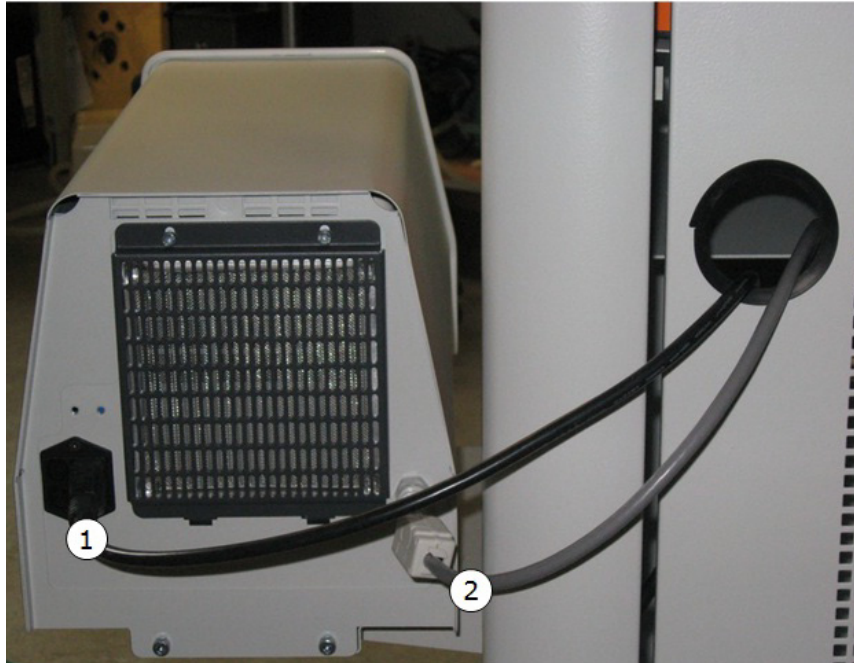


Fig. 161. Cooling unit connections

1	Power cable
2	Fixed cable to Nexstim TMS II



## Appendix C: Configuration example

This chapter describes a configuration example for the Nexstim NBS System.

- Nexstim TMS II is operated through Nexstim NBS (USB link).
- Trigger for Nexstim EMG (EMG Out - Gate In connection).

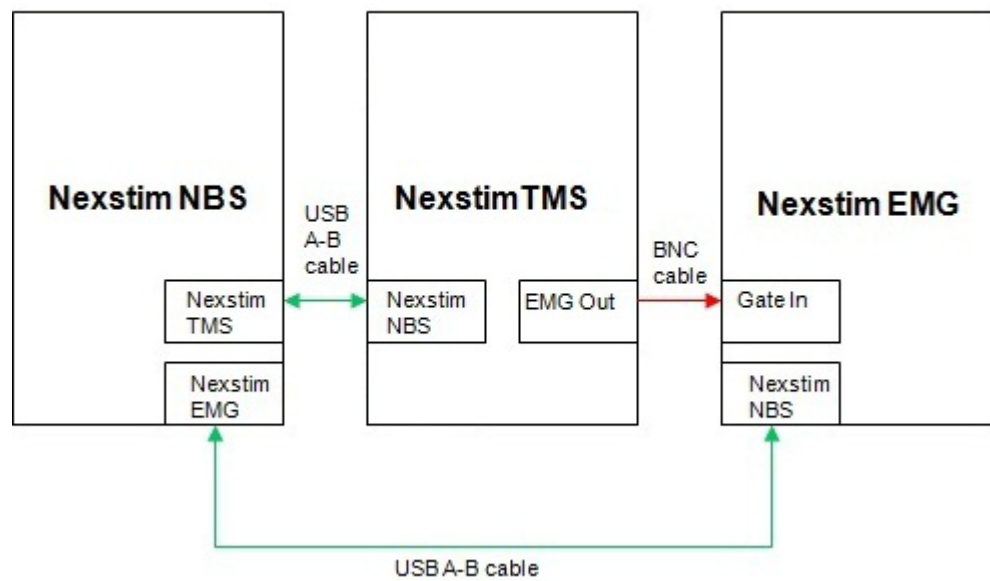


Fig. 162. Nexstim NBS System configuration setup





# Appendix D: EMC emissions and immunity

To fulfil the EMC requirements, use only accessories provided by Nexstim. The Nexstim NBS System uses the following cables:

- BNC cable
- Shielded USB 2.0 cable
- Nexstim EMG electrode cables
- Nexstim EMG GND cable
- Power cord.

The Nexstim NBS System is intended for use in the electromagnetic environment specified in the following tables:

- Table 59 “Electromagnetic emissions”
- Table 60 “Electromagnetic immunity”
- Table 61 “Recommended separation distances between portable and mobile RF communications equipment and the Nexstim NBS System”.

The customer or the user of Nexstim NBS System should assure that it is used in such an environment.

Table 59 Electromagnetic emissions

<b>Guidance and manufacturer’s declaration - Electromagnetic emissions</b>		
The Nexstim NBS System is intended for use in the electromagnetic environment specified below. The customer or the user of Nexstim NBS System should ensure that it is used in such as environment.		
<b>Emissions test</b>	<b>Compliance</b>	<b>Electromagnetic environment - Guidance</b>
RF emissions CISPR 11	Group 1	The Nexstim NBS System uses RF energy only for its internal function. Therefore, its RF emissions are very low and are not likely to cause any interference in nearby electronic equipment.

Table 59 Electromagnetic emissions


<b>Guidance and manufacturer's declaration - Electromagnetic emissions</b>		
The Nexstim NBS System is intended for use in the electromagnetic environment specified below. The customer or the user of Nexstim NBS System should ensure that it is used in such as environment.		
<b>Emissions test</b>	<b>Compliance</b>	<b>Electromagnetic environment - Guidance</b>
RF emissions CISPR 11	Class A	The Nexstim NBS System is suitable for use in all establishments other than domestic, and may be used in domestic establishments and those directly connected to the public low-voltage power supply network that supplies buildings used for domestic purposes, provided the following warning is heeded:
Harmonic emissions IEC 61000-3-2	N/A	
Voltage fluctuations/ flicker emissions IEC 61000-3-3	Complies	
		 <p><b>WARNING:</b> The Nexstim NBS System is intended for use by health care professionals only. The Nexstim NBS System may cause radio interference or may disrupt the operation of nearby equipment. It may be necessary to take mitigation measures, such as re-orienting or relocating the Nexstim NBS System or shielding the location.</p>


Table 60 Electromagnetic immunity

<b>Guidance and manufacturer's declaration - Electromagnetic immunity</b>			
The Nexstim NBS System is intended for use in the electromagnetic environment specified below. The customer or the user of Nexstim NBS System should ensure that it is used in such as environment.			
<b>Immunity test</b>	<b>IEC 60601 test level</b>	<b>Compliance level</b>	<b>Electromagnetic environment - Guidance</b>
Electrostatic discharge (ESD) IEC 6100-4-2	±6 kV contact ±8 kV air	Meets requirement. (Brief disturbance in EMG data may be visible)	Floors should be wood, concrete or ceramic tile. If floors are covered with synthetic material, the relative humidity should be at least 30%.
Electrical fast transient/burst IEC 61000-4-4	±2 kV for power supply lines ±1 kV for input/output lines	Meets requirement. (Brief disturbance in EMG data may be visible)	Mains power quality should be that of a typical commercial or hospital environment.
Surge IEC 61000-4-5	±1 kV differential mode ±2kV common mode	Meets requirement. (Brief disturbance in EMG data may be visible)	Anti surge protection needs to be incorporated into the main supply to the equipment if surge protection is to be guaranteed.

Table 60 Electromagnetic immunity

<b>Guidance and manufacturer's declaration - Electromagnetic immunity</b>			
The Nexstim NBS System is intended for use in the electromagnetic environment specified below. The customer or the user of Nexstim NBS System should ensure that it is used in such as environment.			
<b>Immunity test</b>	<b>IEC 60601 test level</b>	<b>Compliance level</b>	<b>Electromagnetic environment - Guidance</b>
Voltage dips, short interruptions, and voltage variations on power supply input lines IEC 61000-4-11	<5% <i>UT</i> (>95% dip in <i>UT</i> ) for 0.5 cycle 40% <i>UT</i> (60% dip in <i>UT</i> ) for 5 cycles 70% <i>UT</i> (30% dip in <i>UT</i> ) for 25 cycles <5% <i>UT</i> (>95% dip in <i>UT</i> ) for 5 sec	Meets requirement	Mains power quality should be that of a typical commercial or hospital environment. If the user of the Nexstim NBS requires continued operation during power interruptions, it is recommended that the Nexstim NBS system be powered from an uninterruptible power supply.
<b>NOTE:</b> <i>UT</i> is the a.c mains voltage prior to application of the test level.			
Power frequency (50/60 Hz) magnetic field IEC 61000-4-8	3 A/m	Meets requirement	Power frequency magnetic fields should be measured to guarantee suitable level of the field at the installation site.

Table 60 Electromagnetic immunity

<b>Guidance and manufacturer's declaration - Electromagnetic immunity</b>			
The Nexstim NBS System is intended for use in the electromagnetic environment specified below. The customer or the user of Nexstim NBS System should ensure that it is used in such as environment.			
<b>Immunity test</b>	<b>IEC 60601 test level</b>	<b>Compliance level</b>	<b>Electromagnetic environment - Guidance</b>
Conducted RF IEC 61000-4-6 Radiated RF IEC 61000-4-3	3 V <sub>rms</sub> 150 KHz to 80 MHz 3 V/m 80 MHz to 2,5 GHz	3 V <sub>rms</sub> 3 V/m	<p>Portable and mobile RF communications equipment should be used no closer to any part of the Nexstim NBS System, including cables, than the recommended separation distance calculated from the equation applicable to the frequency transmitter.</p> <p><b>Recommended separation distance</b></p> <p>150 KHz to 80 MHz</p> $d = 1, 2\sqrt{P}$ <p>80 MHz to 800 MHz</p> $d = 1, 2\sqrt{P}$ <p>800 MHz to 2,5 GHz</p> $d = 2, 3\sqrt{P}$ <p>Where <math>P</math> is the maximum output power rating of the transmitter in watts (W) according to the transmitter manufacturer and <math>d</math> is the recommended separation distance in metres (m). Field strengths from fixed RF transmitters, as determined by an electromagnetic site survey,<sup>a</sup> should be less than the compliance level in each frequency range.<sup>b</sup></p> <p>Interference may occur in the vicinity of equipment marked with the following symbol:</p> 
<p><b>NOTE 1:</b> At 80MHz and 800 MHz, the higher frequency range applies.</p> <p><b>NOTE 2:</b> These guidelines may not apply in all situations. Electromagnetic propagation is affected by absorption and reflection from structures, objects and people.</p>			

- a. Field strengths from fixed transmitters, such as base stations for radio (cellular/cordless) telephones and land mobile radios, amateur radio, AM and FM radio broadcast and TV broadcast cannot be predicted theoretically with accuracy. To assess the electromagnetic environment due to fixed RF transmitters, an electromagnetic site survey should be considered. If the measured field strength in the location in which the Nexstim NBS system is used exceeds the applicable RF compliance level above, the Nexstim NBS System should be observed to verify normal operation. If abnormal performance is observed, additional measures may be necessary, such as reorienting or relocating the Nexstim NBS System.
- b. Over the frequency range 150 kHz to 80 MHz, field strengths should be less than 3 V/m.

Table 61 Recommended separation distances between portable and mobile RF communications equipment and the Nexstim NBS System

<b>Recommended separation distances between portable and mobile RF communications equipment and the Nexstim NBS System</b>			
The Nexstim NBS System is intended for use in the electromagnetic environment in which radiated RF disturbances are controlled. The customer or the user of Nexstim NBS System can help prevent electromagnetic interference by maintaining a minimum distance between portable and mobile RF communications equipment (transmitters) and the Nexstim NBS System as recommended below, according to the maximum output power of the communications equipment.			
Rated maximum output power of transmitter <b>W</b>	Separation distance according to frequency of transmitter <b>m</b>		
	150 KHz to 80 MHz	80 MHz to 800 MHz	800 MHz to 2,5 GHz
	$d = 1,2\sqrt{P}$	$d = 1,2\sqrt{P}$	$d = 2,3\sqrt{P}$
0,01	0,12	0,12	0,23
0,1	0,37	0,37	0,74
1	1,12	1,12	2,33
10	3,67	3,67	7,34
100	11,67	11,67	23,33
For transmitters rated at a maximum output power not listed above, the recommended separation distance <i>d</i> in metres (m) can be estimated using the equation applicable to the frequency of the transmitter, where <i>P</i> is the maximum output power rating of the transmitter in watts (W) according to the transmitter manufacturer.			
<b>NOTE 1:</b> At 80 MHz and 800 MHz, the separation distance for the higher frequency range applies.			
<b>NOTE 2:</b> These guidelines may not apply in all situations. Electromagnetic propagation is affected by absorption and reflection from structures, objects and people.			



## Appendix E: DICOM export

---

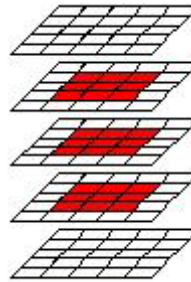
**NOTE:**

For DICOM tag descriptions, refer to document *Nexstim NBS DICOM Conformance Statement for DICOM Export*.

---

In the case of DICOM overlay exports, the DICOM export contains only colored voxels generated by the NBS and a small area from the original image around the landmarks. Otherwise the export contains voxels painted with color index 0.

In the case of DICOM fusion exports, the DICOM export contains a copy of the original image, on top of which the NBS results have been fused as white voxels.



**Fig. 163.** The shape of the stimulus is 3x3x3 colored voxels

The original image is stored separately to the session folder and is not modified. Only the files belonging to the same series are stored.

The exported image has the same slice orientation and direction as the original image.

The export image has the same width and height as the original image.

### E.1 DICOM overlay export

#### E.1.1 DICOM image file contents

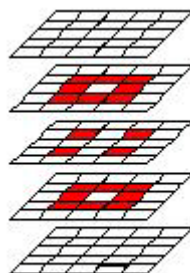
The center of the landmark in the export is in the same position as the landmark in NBS.

The color index of the voxel in the center of the landmark is 32767.

The color index of the other voxels in the landmark is 32638.

The shape of the stimulus is 3x3x3 colored voxels if the stimulus has a response (see Figure 163). A sphere with radius of 15 voxels around the landmarks is copied from the original image to the DICOM export.

The stimulus, of which the response is below the response limit, is marked with the shape of 3x3x3 voxels. Some voxels of the shape are not colored so that the stimulus can be differentiated from the stimulus of which the response is the same as or above the response limit (see Figure 164).



**Fig. 164.** If the stimulus has no response or the response is below the response limit, some voxels are not colored

The center of the stimulus in the export is in the same location as the maximum electric field of the stimulus in the exported peeling depth.

When using the “Voltage scale”, “Normalized between min and max” or “Response On/Off” map types, note that if several stimuli are located on the same spot, the highest color index (that is, the strongest MEP value) will be written to the DICOM export.

### “Voltage scale” color indexing

The color index of the stimulus depends on the EMG channel having the strongest response according the following table:

Table 62 “Voltage scale” map setting

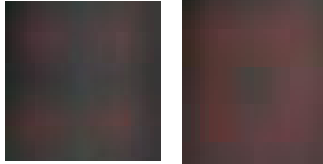
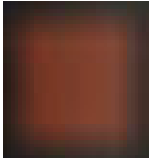

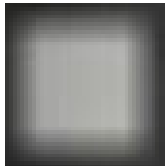
Response value	Color index	Stimulus visualized on the slice view
0 - 50	3854	 Center      Edge
50 - 500	10922	



Table 62 “Voltage scale” map setting

Response value	Color index	Stimulus visualized on the slice view
500 - 1000	21844	
1000 -	32638	

**“Channel color of strongest response” color indexing**

The color index of the stimulus is determined according to specific calculations, and depends on the EMG channel having the strongest response.

Table 63 “Channel color of strongest response” map setting

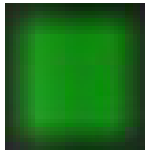
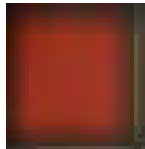
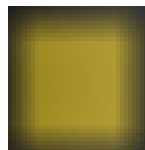

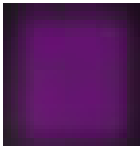
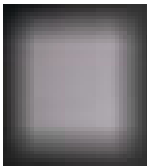
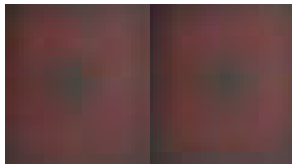
Channel containing the strongest response	Color index	Stimulus visualized on the slice view
EMG1	16576	
EMG2	5525	
EMG3	11050	
EMG4	22101	

Table 63 “Channel color of strongest response” map setting

Channel containing the strongest response	Color index	Stimulus visualized on the slice view
EMG5	27498	
EMG6	32638	
User response	1284	
All channels below response limit	1284	

When using the “Channel color of strongest response” map type, note that if several stimuli are located on the same spot:

- EMG6 may overwrite EMG5.
- EMG5 may overwrite EMG4.
- EMG4 may overwrite EMG1.
- EMG1 may overwrite EMG3.
- EMG3 may overwrite EMG2.
- EMG2 may overwrite the user response or all stimuli below the response limit.

### “Normalized between min and max” color indexing

In “Normalized between min and max” map setting, the color index of the stimulus is based on the response level to range from 4882 to 32638, with specific rules. If the stimulus does not have a response, color index 3854 is used.

Table 64 “Normalized between min and max” map setting

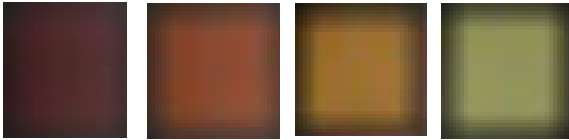
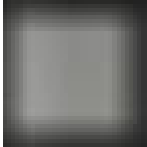
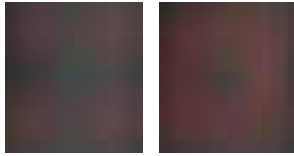
Response limit	Color index	Stimulus visualized on the slice view
Minimum normalized value	4882	

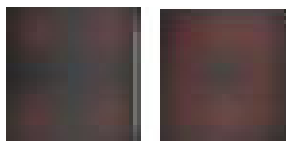
Table 64 “Normalized between min and max” map setting

Response limit	Color index	Stimulus visualized on the slice view
Maximum normalized value	32638	
No response	3854	

### “Response On/Off” color indexing

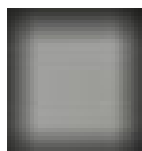
The color index of the stimulus depends on the EMG channel having the strongest response.

The color index of the stimulus is 3854 in the DICOM export which contains only the stimuli of which the response is below the response limit (that is, below the response limit export). See Figure 165.



**Fig. 165.** Example of a stimulus below the response limit (center on the left, edge on the right) in the slice view after the DICOM export has been loaded into Nexstim NBS

The color index of the stimulus is 32638 in the DICOM export which contains only the stimuli of which the response is the same as or above the response limit (that is, above the response limit export). See Figure 166.



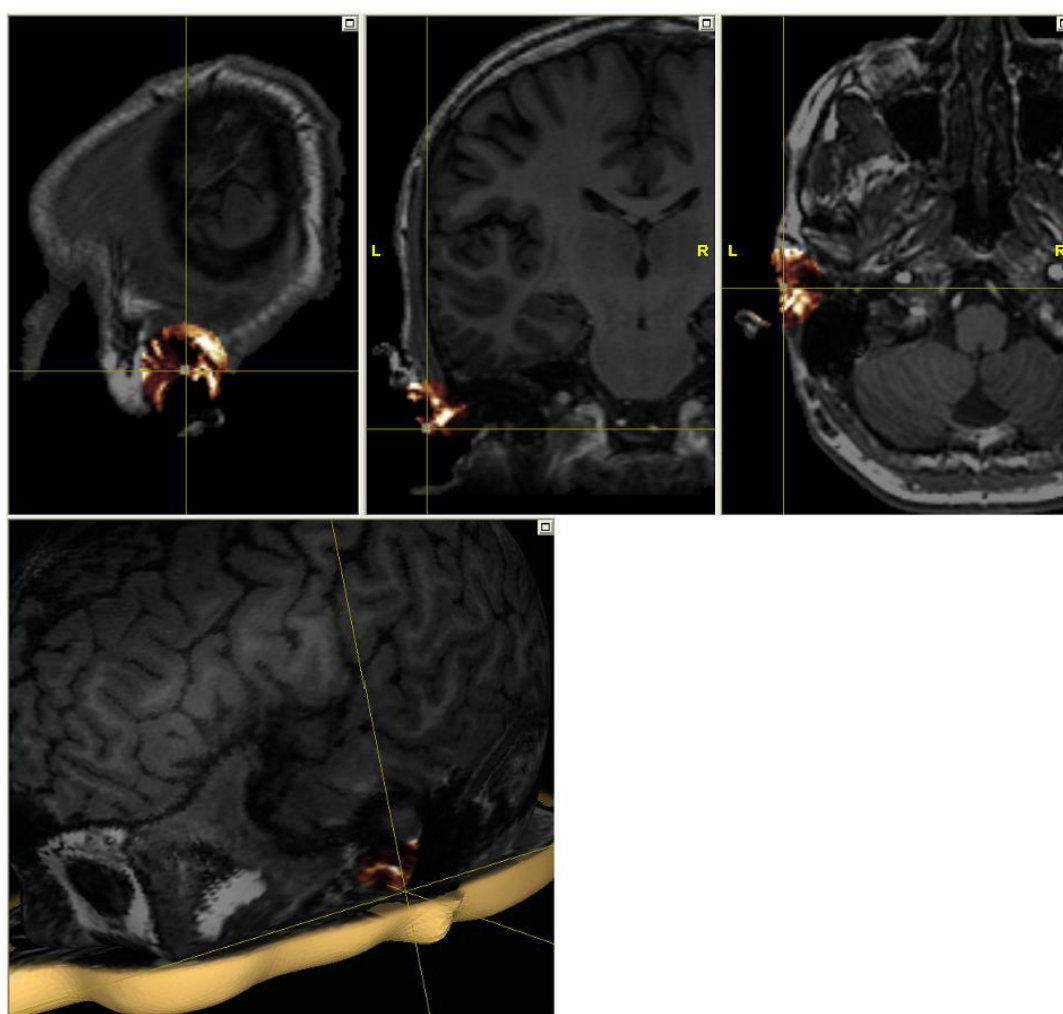
**Fig. 166.** Example of a stimulus same as or above the response limit in the slice view after the DICOM export has been loaded into Nexstim NBS

## E.1.2 DICOM overlay export visualization in Nexstim NBS

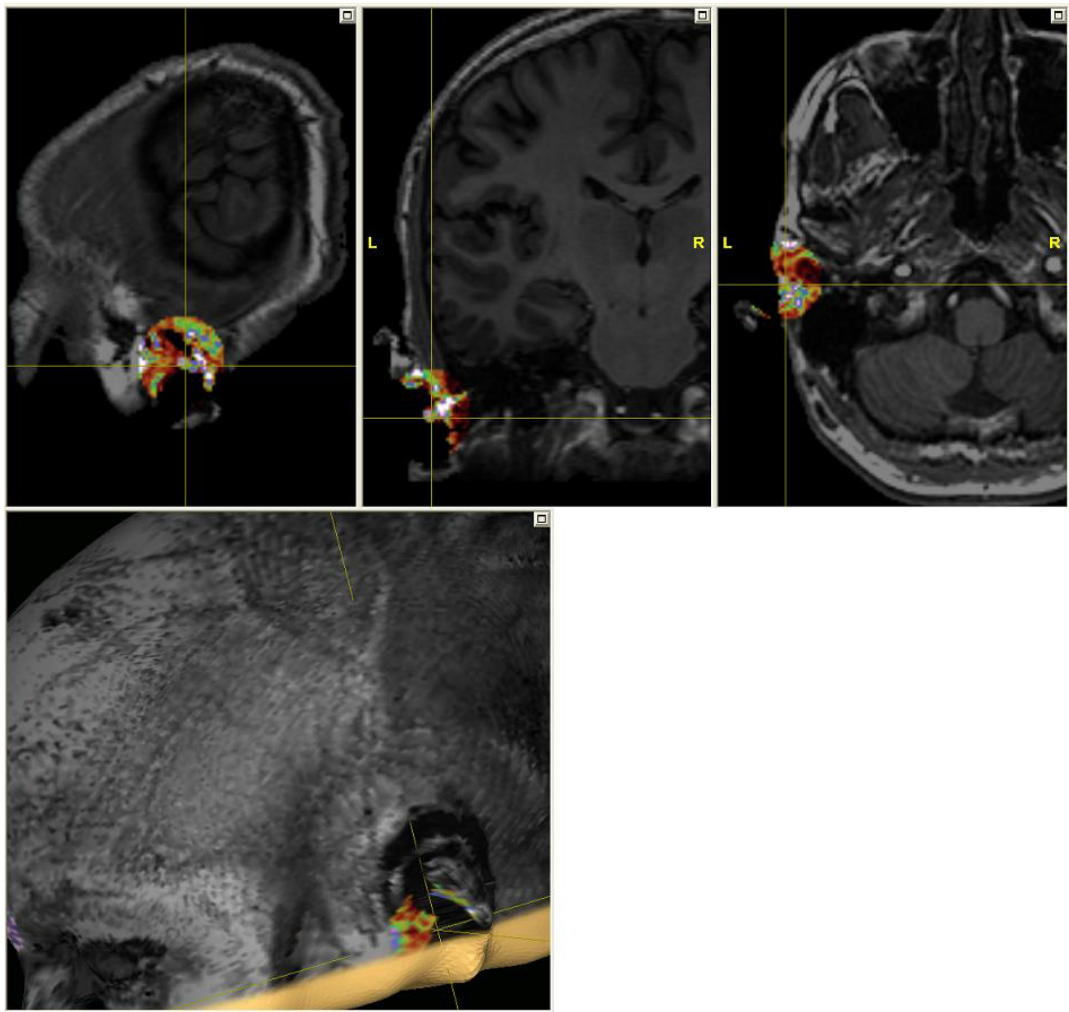
The following screenshots show examples of the landmark locations after the DICOM export has been loaded into Nexstim NBS. The landmarks are visualized in all three directions in the MR images, as well as in the 3D head.

### Location of the left ear landmark

Figure 167 and Figure 168 show examples of the visualization of the left ear landmark in heat and rainbow colormaps, after the DICOM export has been loaded into Nexstim NBS.



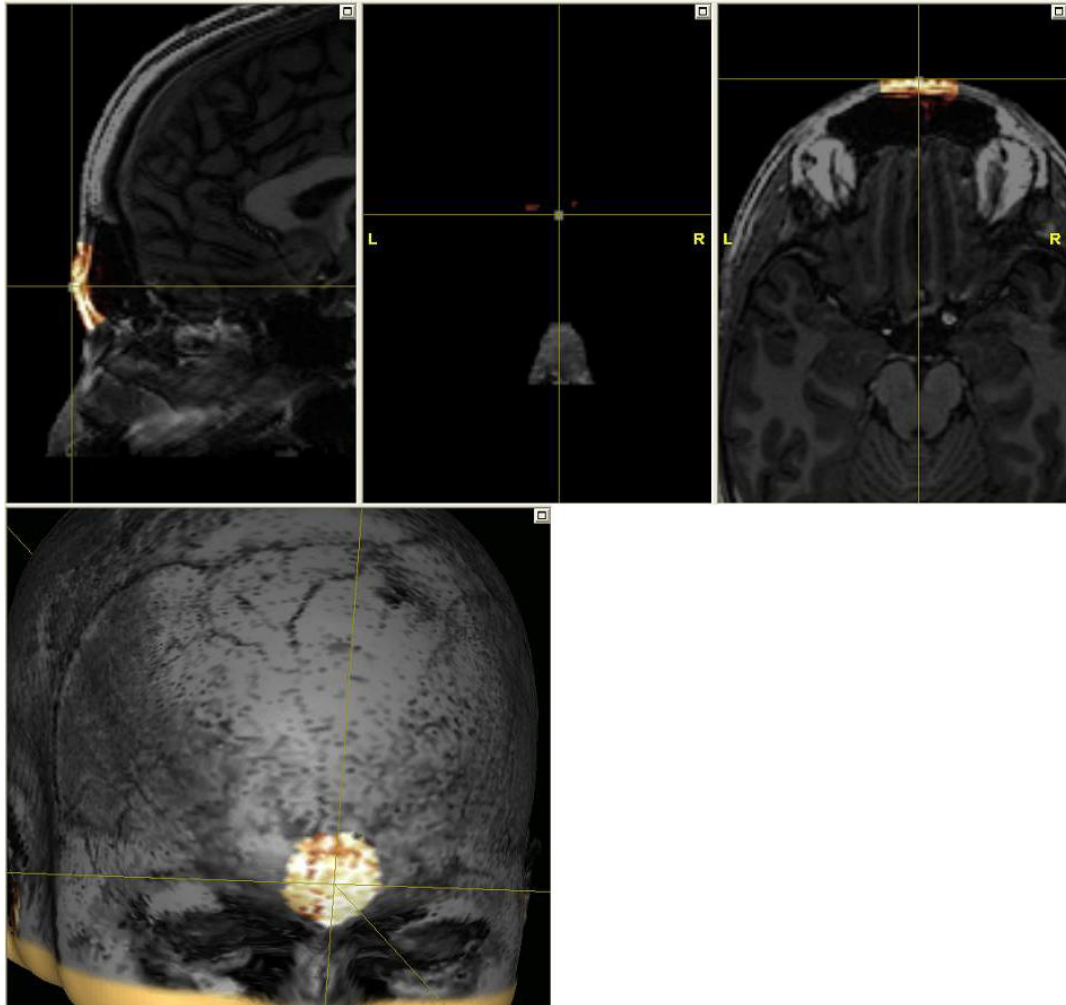
**Fig. 167.** Heat colormap: Location of the left ear landmark in MR images and 3D head



**Fig. 168.** Rainbow colormap: Location of the left ear landmark in the MR images and 3D head

## Location of the nasion landmark

Figure 169 and Figure 170 show examples of the visualization of the nasion landmark in heat and rainbow colormaps, after the DICOM export has been loaded into Nexstim NBS.



**Fig. 169.** Heat colormap: Location of the nasion landmark in the MR images and 3D head

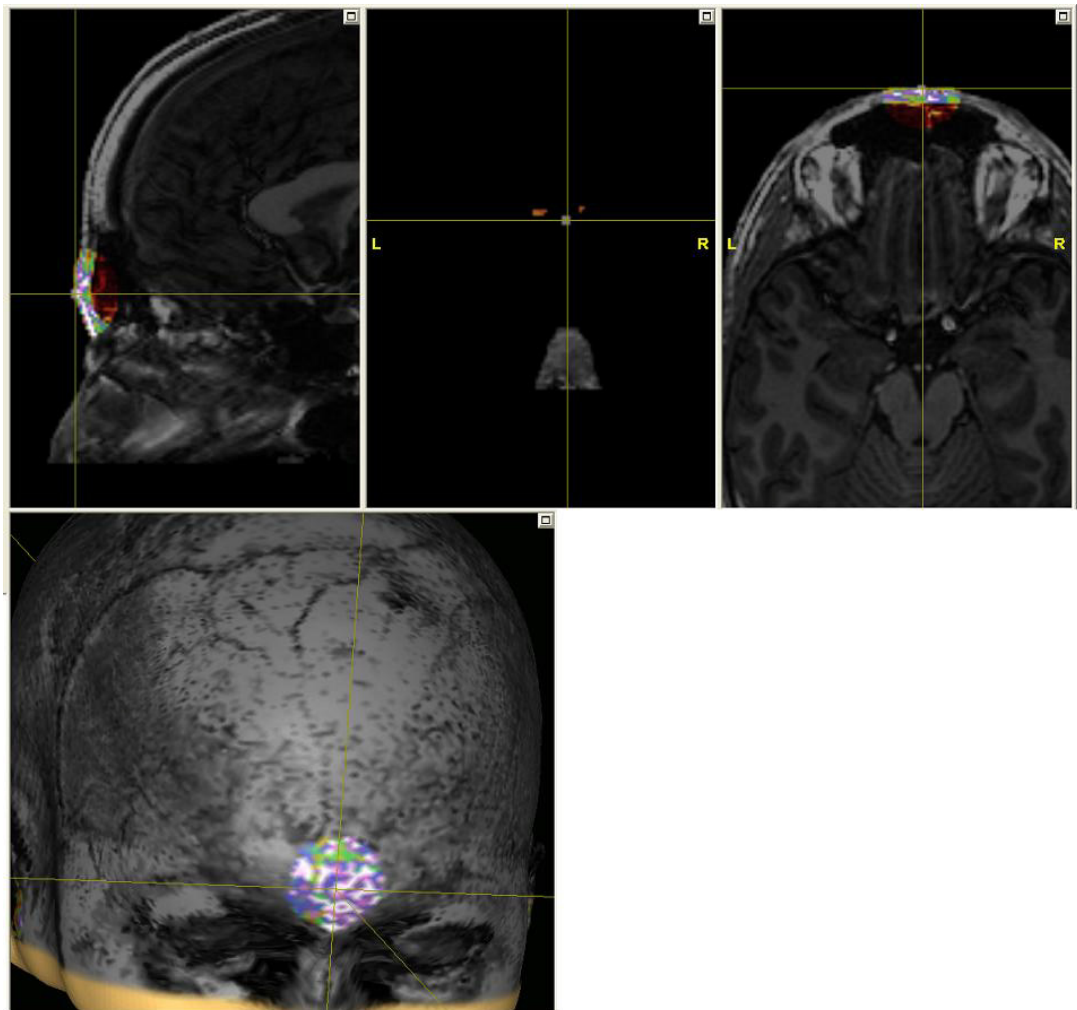
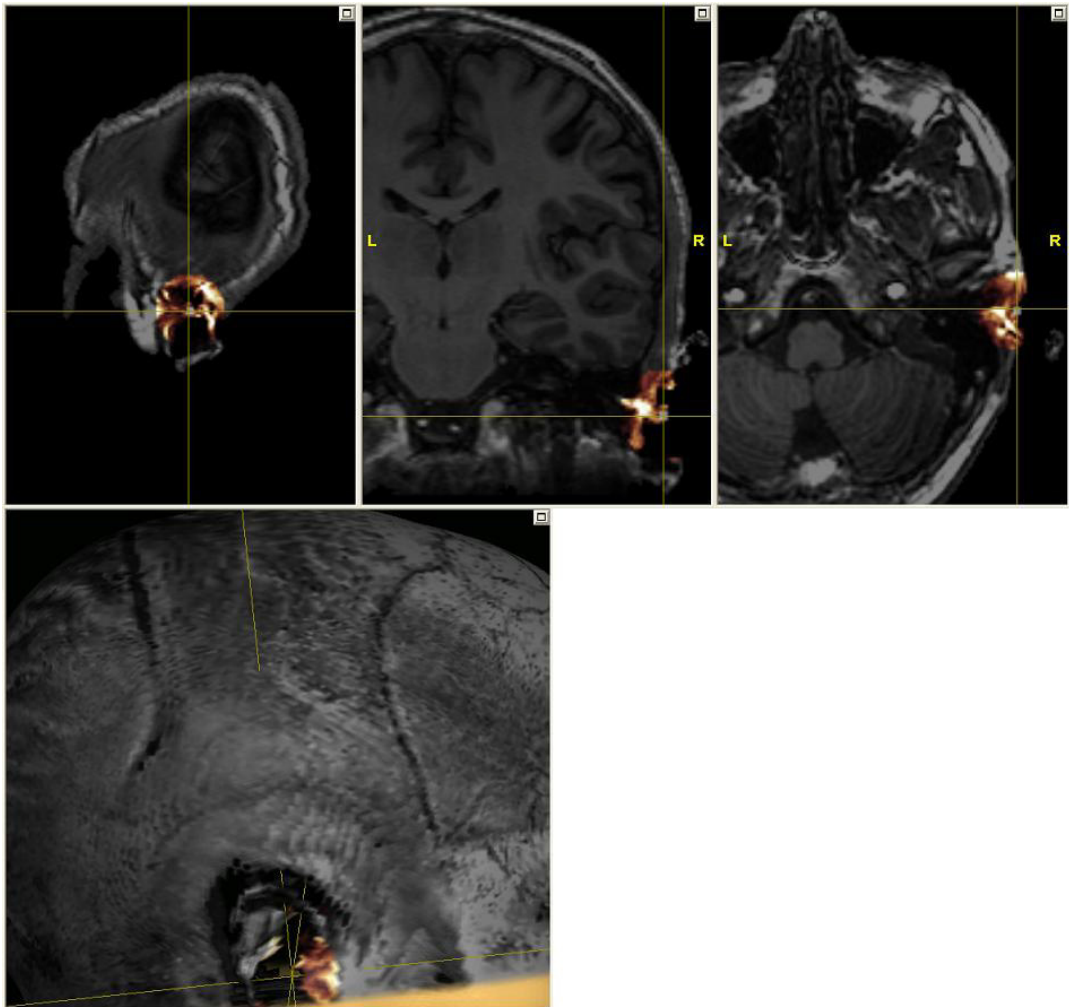


Fig. 170. Rainbow colormap: Location of the nasion landmark in the MR images and 3D head

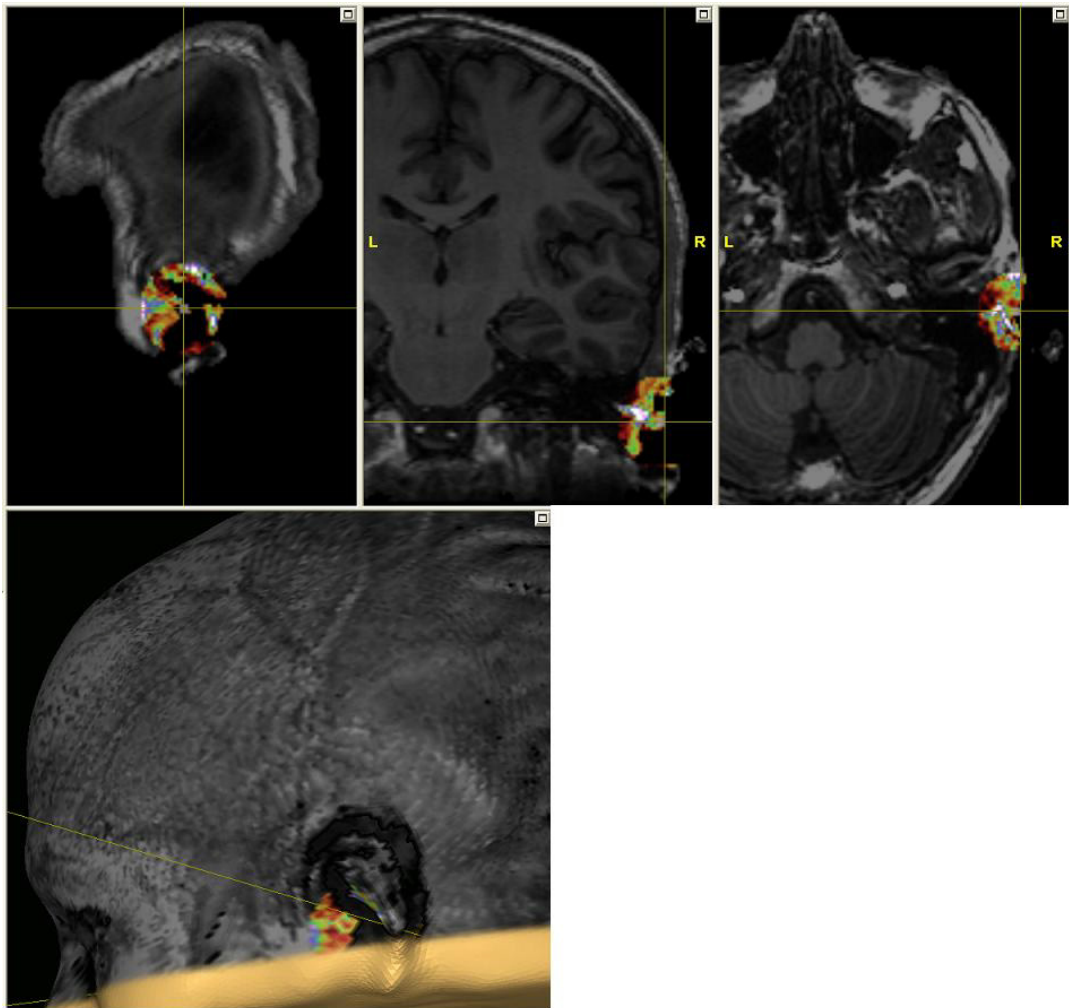
## Location of the right ear landmark

Figure 171 and Figure 172 show examples of the visualization of the left ear landmark in heat and rainbow colormaps, after the DICOM export has been loaded into Nexstim NBS.

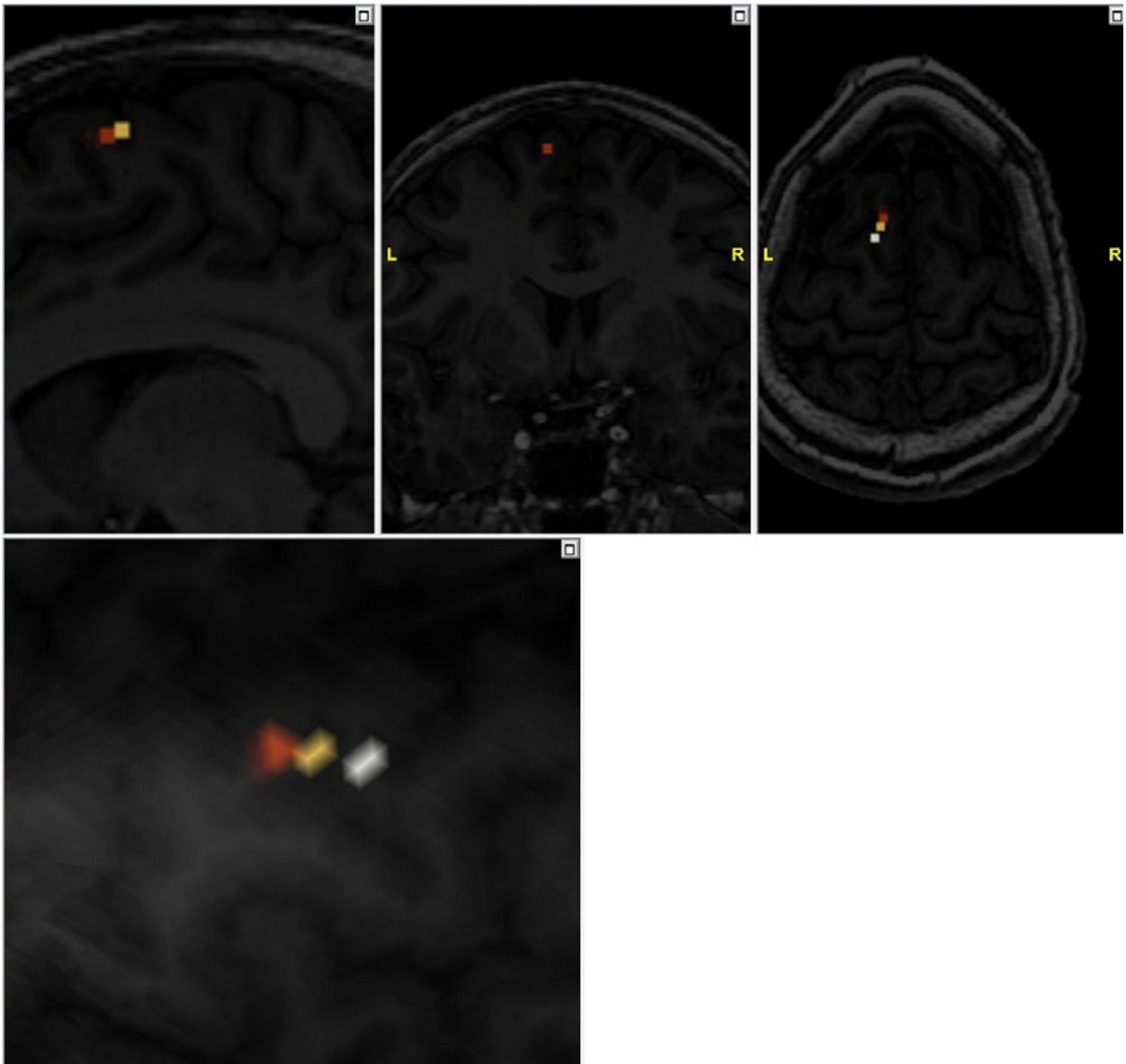


**Fig. 171.** Heat colormap: Location of the right ear landmark in MR images and 3D head

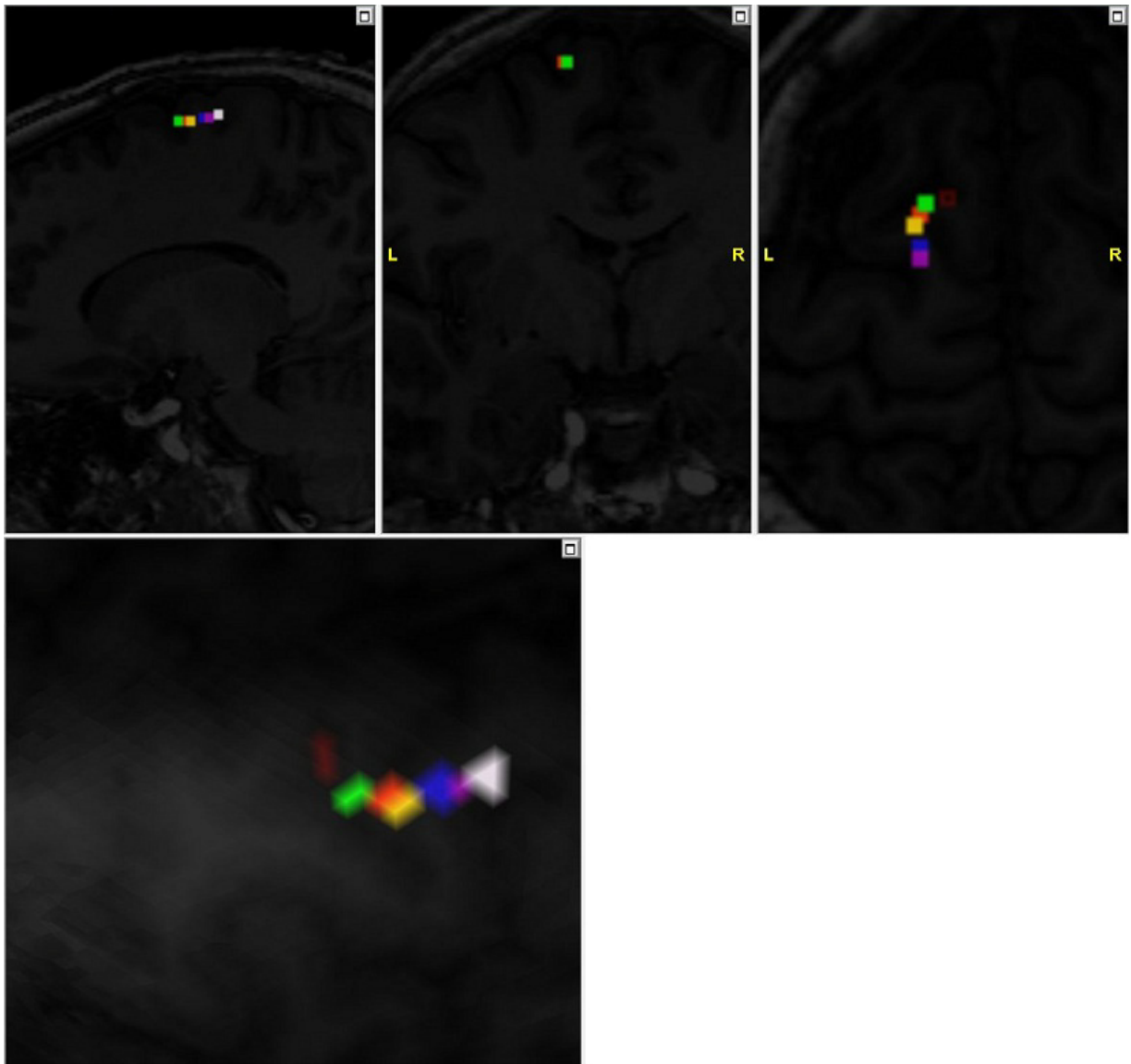




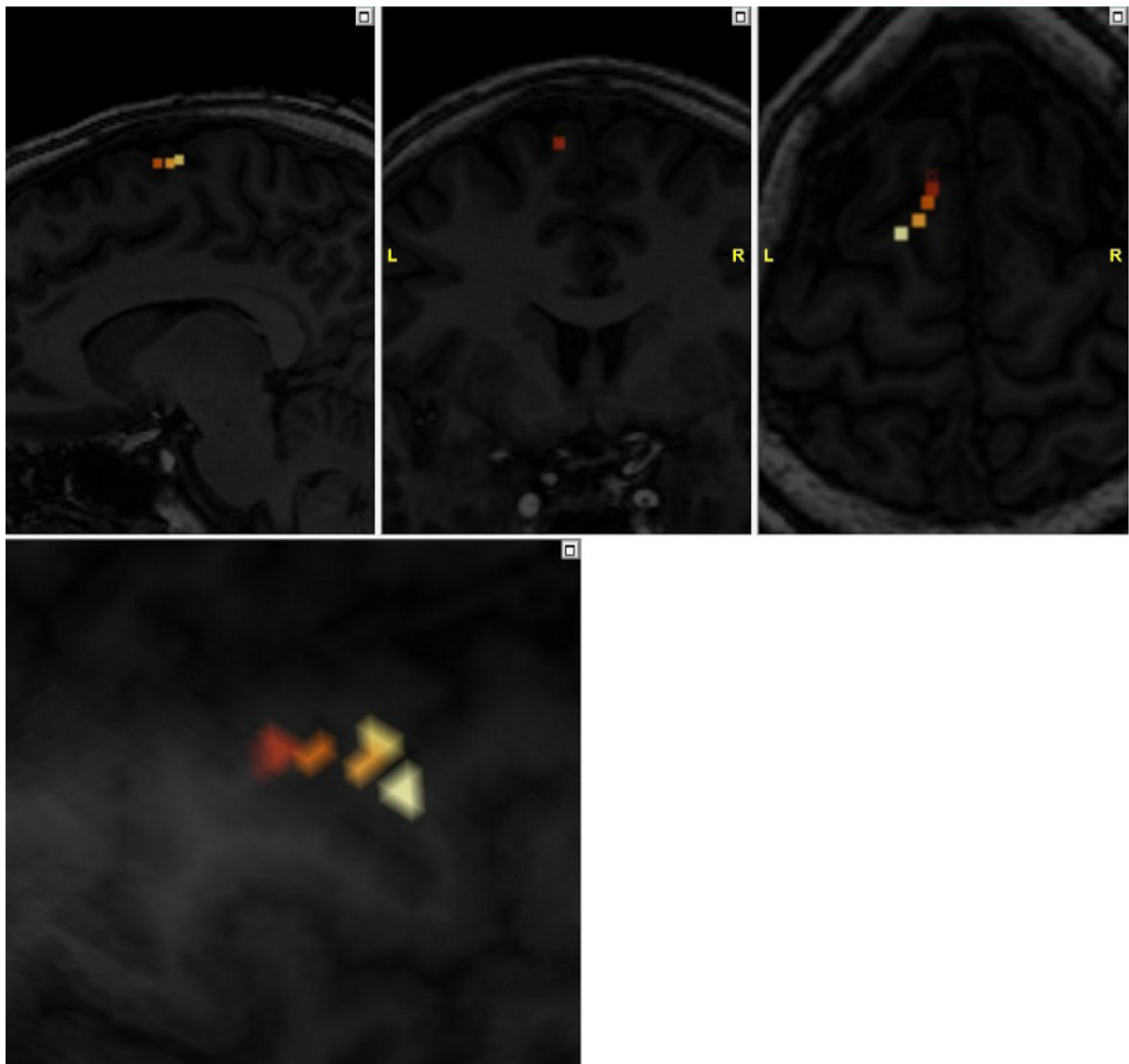
**Fig. 172.** Rainbow colormap: Location of the right ear landmark in MR images and 3D head

**Stimulus visualization on the MR images and 3D head**

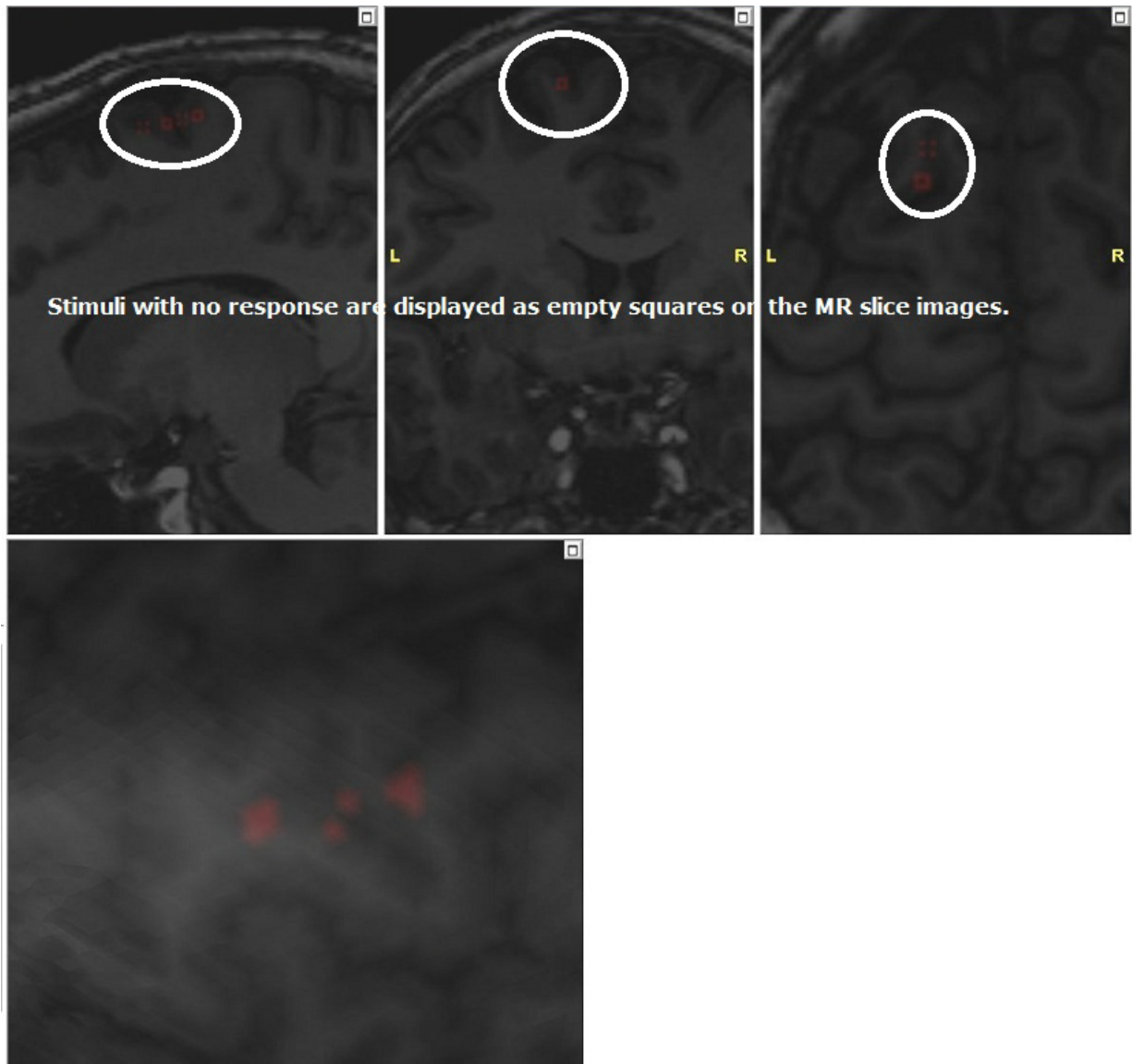
**Fig. 173.** DICOM export overlay when the “Voltage scale” mapping is selected (Heat colormap)



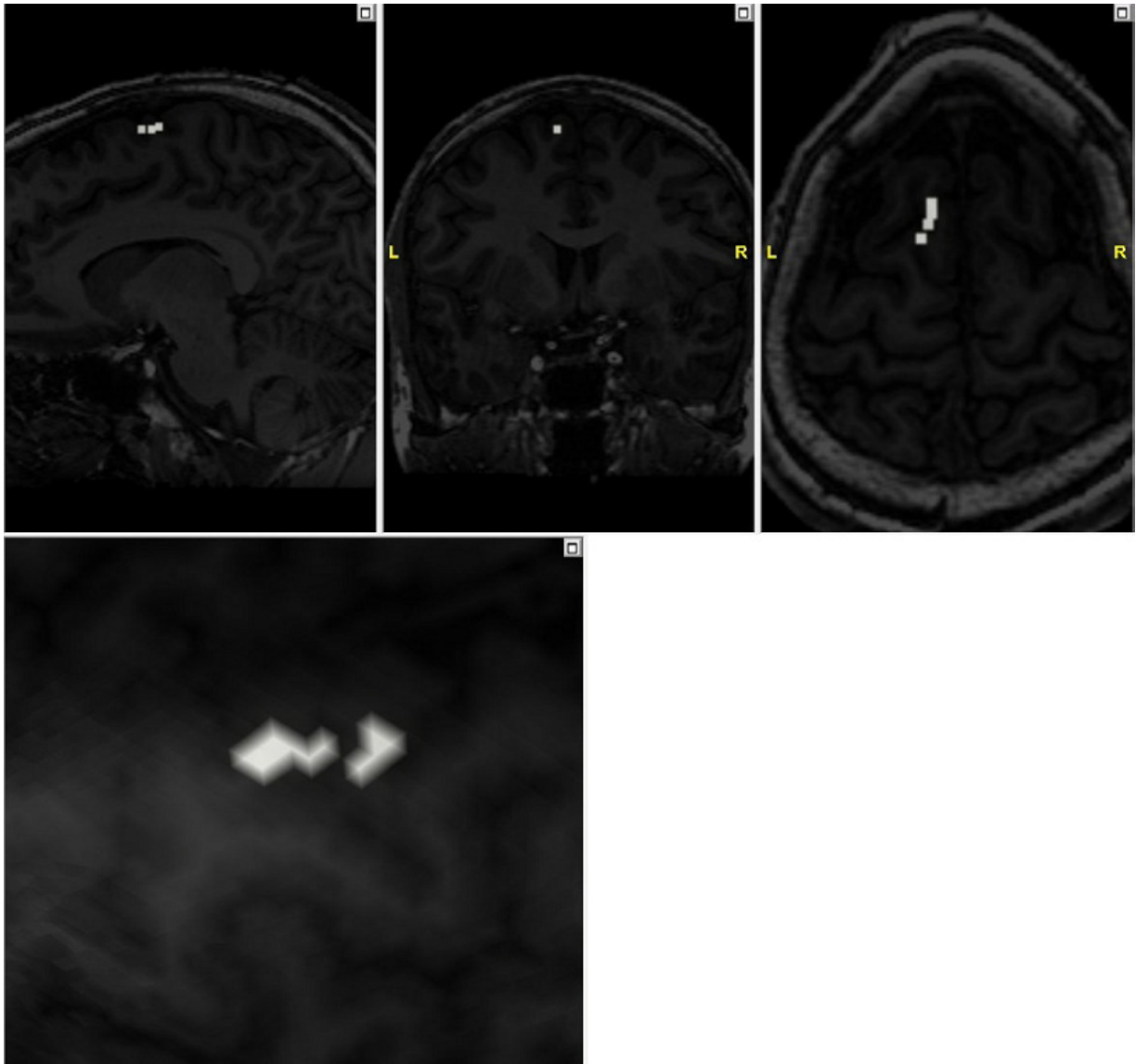
**Fig. 174.** DICOM export overlay when the “Channel color of strongest response” mapping is selected (Rainbow colormap)



**Fig. 175.** DICOM export overlay when the “Normalized between min and max” mapping is selected (Heat colormap)



**Fig. 176. Only DICOM overlay:** DICOM export overlay showing stimuli below the response limit when the “Response On/Off” mapping is selected (Heat colormap)



**Fig. 177. Only DICOM overlay:** DICOM export overlay showing stimuli above the response limit when the “Response On/Off” mapping is selected (Heat colormap)

## E.2 DICOM text export contents

This chapter describes the DICOM text export contents (Table 65) and an example of a DICOM text export (Figure 178).

The DICOM export creates a text file to the following directory:

*<session directory>\DICOMExport\ <DICOM export directory>*

The text file describes the content of the DICOM export. It is used for checking that the external system displays the DICOM export correctly. The text file is in format *<patient name>\_<date and time of the export>.txt*.

Table 65 DICOM text export contents

Field name	Definition
Report created	<i>&lt;date and time when the export was created&gt;</i>
Session information	<ul style="list-style-type: none"> <li>• Filename <i>&lt;name of the session file&gt;</i></li> <li>• Researcher <i>&lt;researcher of the session&gt;</i></li> <li>• Organization <i>&lt;organization of the session&gt;</i></li> <li>• Description <i>&lt;description of the session&gt;</i></li> <li>• Created <i>&lt;date and time when the session was created&gt;</i></li> </ul>
Patient information	<ul style="list-style-type: none"> <li>• Name <i>&lt;name of the patient&gt;</i></li> <li>• ID <i>&lt;patient id of the patient&gt;</i></li> <li>• Age <i>&lt;age of the patient&gt;</i></li> <li>• Gender <i>&lt;gender of the patient&gt;</i></li> <li>• Handedness <i>&lt;handedness of the patient&gt;</i></li> </ul>
Equipment information	Repeated for every stimulator/coil used for stimulation: <ul style="list-style-type: none"> <li>• Stimulator name <i>&lt;name of the stimulator&gt;</i></li> <li>• Coil name <i>&lt;name of the coil&gt;</i></li> </ul>
Stimulus set information	Generated if the DICOM export is created from stimulation sequence: <ul style="list-style-type: none"> <li>• Sequence created <i>&lt;date when the stimulation session was created&gt;</i></li> <li>• Sequence description <i>&lt;description of the stimulation sequence&gt;</i></li> </ul> Generated if the DICOM export is created from analysis exam: <ul style="list-style-type: none"> <li>• Exam created <i>&lt;date when the analysis exam was created&gt;</i></li> <li>• Exam researcher <i>&lt;researcher of the analysis exam&gt;</i></li> <li>• Exam description <i>&lt;description of the analysis exam&gt;</i></li> </ul>

Table 65 DICOM text export contents

Field name	Definition
Original image stack information (subset of DICOM tags)	<p>From the original image:</p> <ul style="list-style-type: none"> <li>• Patient name (0010,0010)</li> <li>• Patient ID (0010,0020)</li> <li>• Patient Date of Birth (0010,0030)</li> <li>• Patient's Sex (0010,0040)</li> <li>• Study Instance UID (0020,000d)</li> <li>• Study Date (0008,0020)</li> <li>• Study Time (0008,0030)</li> <li>• Referring Physician's name (0008,0090)</li> <li>• Study ID (0020,0010)</li> <li>• Accession Number (0008,0050)</li> <li>• Series Instance UID (0020,000e)</li> <li>• Series Number (0020,0011)</li> <li>• Series Date (0008,0021)</li> <li>• Series Time (0008,0031)</li> <li>• Series Description (0008,103e)</li> <li>• Frame of Reference UID (0020,0052)</li> <li>• Content Date (0008,0023)</li> <li>• Content Time (0008,0033)</li> <li>• Acquisition Number (0020,0012)</li> <li>• Acquisition Date (0008,0022)</li> <li>• Acquisition Time (0008,0032)</li> </ul>



Table 65 DICOM text export contents

Field name	Definition
DICOM export stack information (subset of DICOM tags)	<p>From the DICOM export:</p> <ul style="list-style-type: none"> <li>• Patient name (0010,0010)</li> <li>• Patient ID (0010,0020)</li> <li>• Patient Date of Birth (0010,0030)</li> <li>• Patient's Sex (0010,0040)</li> <li>• Study Instance UID (0020,000d)</li> <li>• Study Date (0008,0020)</li> <li>• Study Time (0008,0030)</li> <li>• Referring Physician's name (0008,0090)</li> <li>• Study ID (0020,0010)</li> <li>• Accession Number (0008,0050)</li> <li>• Series Instance UID (0020,000e)</li> <li>• Series Number (0020,0011)</li> <li>• Series Date (0008,0021)</li> <li>• Series Time (0008,0031)</li> <li>• Series Description (0008,103e)</li> <li>• Frame of Reference UID (0020,0052)</li> <li>• Content Date (0008,0023)</li> <li>• Content Time (0008,0033)</li> <li>• Acquisition Number (0020,0012)</li> <li>• Acquisition Date (0008,0022)</li> <li>• Acquisition Time (0008,0032)</li> </ul>
Mapping information	<p><b>DICOM overlay:</b></p> <p><i>&lt;Name of the map setting from the Map Settings -dialog: "Voltage scale", "Channel color of strongest response", "Normalized between min and max", "Responses same as or above response limit", or "Responses below response limit"&gt;</i></p> <p><b>DICOM fusion images:</b></p> <p><i>&lt;"Responses below response limit"&gt;</i></p>

Table 65 DICOM text export contents

Field name	Definition
Stimulus information	Repeated for every selected peeling depth: Peeling depth <peeling depth> mm
	Repeated for every selected stimulus: ID (<1>) Int(<2>%) Expv(<3>) <4> EF max (x, y, z) : <5> <6> ) Where <1>: The ID of stimulus in the session tree <2>: The intensity of the stimulus <3>: The color index of the stimulus in the DICOM export <4>: List of peak-to-peak and latency or user response values for every channel selected in the map settings. The format of one field in the list depends on the channel: <ul style="list-style-type: none"> <li>• EMG1-6:               <ul style="list-style-type: none"> <li>- Peak-to-peak value characters 'ms', or character '-' if the value is missing.</li> <li>- Latency value and characters 'µV', or character '-' if the value is missing</li> </ul> </li> <li>• User response: User response value or character '-' if the value is missing.</li> </ul> <5>: The EF max location of the stimulus in the current peeling depth in voxel indexes. The format of the field is "MRI voxels(<x>, <y>, <z>)" <6>: The EF max location of the stimulus in the coordinate system selected in the NBS. The format of the field depends on the selected coordinate system according to the following: <ul style="list-style-type: none"> <li>• Head coordinate system: Head coordinates(&lt;x&gt;, &lt;y&gt;, &lt;z&gt;)</li> <li>• MRI-coordinate system: MRI coordinates(&lt;x&gt;, &lt;y&gt;, &lt;z&gt;)</li> <li>• MR scanner coordinate system: MR scanner coordinates(&lt;x&gt;, &lt;y&gt;, &lt;z&gt;).</li> </ul>

Figure 178 shows an example of a DICOM text export.

**Fig. 178.** Example of a DICOM text export

```

Report created: 2008.12.03 13.09

Session information:
  Filename: ge_ax_dicom_2008_12_02_12_10_47.nbs
  Researcher: Joe Doe
  Organisation: Hospital A
  Description: NBS mapping of the patient
  Created: 2008.12.02 12.10

Patient information:
  Name: John Doe
  ID: 040472
  Age: 36
  Gender: Male
  Handedness: Right handed

Equipment information:
  Stimulator name: Nexstim TMS II
  Coil name: Nexstim Focal Coil

Stimulus set information:
  Sequence created: 2008.12.02 15.40
  Sequence description: First stimulation sequence

Original image stack information (subset of DICOM tags):
  Patient name (0010,0010): John Doe
  Patient ID (0010,0020): 040472-ABCD
  Patient Date of Birth (0010,0030): 19720404
  Patient's Sex (0010,0040): M
  Study Instance UID (0020,000d): 1.2.246.16288811.55.666.1283244727.357
  Study Date (0008,0020): 20061212
  Study Time (0008,0030): 134314
  Referring Physician's name (0008,0090): Jane Doe
  Study ID (0020,0010): 1008
  Accession Number (0008,0050):
  Series Instance UID (0020,000e): 1.2.246.16288811.55.666.2394355958.994
  Series Number (0020,0011): 7
  Series Date (0008,0021): 20060101
  Series Time (0008,0031): 141134
  Series Description (0008,103e): Ax 3D SPGR_IR_166Slices
  Frame of Reference UID (0020,0052): 1.2.246.16288811.55.666.2394355958.995
  
```

Fig. 178. Example of a DICOM text export

```

Content Date (0008,0023): 20060101
Content Time (0008,0033): 141134
Acquisition Number (0020,0012): 1
Acquisition Date (0008,0022): 20060101
Acquisition Time (0008,0032): 141134

DICOM Export stack information (subset of DICOM tags):
Patient name (0010,0010): John Doe
Patient ID (0010,0020): 040472-ABCD
Patient Date of Birth (0010,0030): 19720404
Patient's Sex (0010,0040): M
Study Instance UID (0020,000d): 1.2.246.16288811.55.666.1283244727.357
Study Date (0008,0020): 20061212
Study Time (0008,0030): 134314
Referring Physician's name (0008,0090): Jane Doe
Study ID (0020,0010): 1008
Accession Number (0008,0050):
Series Instance UID (0020,000e):1.2.246.16288811.55.1.78374228781.2008120313094912256
Series Number (0020,0011): 2812186
Series Date (0008,0021): 20081202
Series Time (0008,0031): 153906.000000
Series Description (0008,103e): NBS mapping
Frame of Reference UID (0020,0052): 1.2.246.16288811.55.666.2394355958.995
Content Date (0008,0023): 20081203
Content Time (0008,0033): 130946.000000
Acquisition Number (0020,0012): 1
Acquisition Date (0008,0022): 20060101
Acquisition Time (0008,0032): 141134

Mapping information:
Voltage Scale

Stimulus Information:
Peeling depth 10 mm

ID(2.2.1.) Int(30%) Expv(10922) EMG1(- -) EMG2(- -) EMG3(278.1uV, 4.7ms) EMG4(- -) EMG5(- -)
EMG6(- -) User Response( - ) EF max (x,y,z) : MRI voxels(144.335, 175.281, 134.909) MRI
coordinates(164.3, 134.7, 103.7)

ID(2.2.2.) Int(30%) Expv(128) EMG1(- -) EMG2(- -) EMG3(- -) EMG4(- -) EMG5(- -) EMG6(- -) User
Response(40.0) EF max (x,y,z) : MRI voxels(144.742, 170.161, 138.224) MRI coordinates(159.5,
138.1, 103.3)

ID(2.2.3.) Int(30%) Expv(10922) EMG1(- -) EMG2(- -) EMG3(- -) EMG4(- -) EMG5(- -) EMG6(- -) User
Response(50.0) EF max (x,y,z) : MRI voxels(143.842, 163.353, 141.663) MRI coordinates(153.1,
141.5, 104.2)

```

Fig. 178. Example of a DICOM text export

```

ID(2.2.4.) Int(30%) Expv(10922) EMG1(- -) EMG2(201.4uV, 25.7ms) EMG3(- -) EMG4(- -) EMG5(- -)
EMG6(- -) User Response(250.0) EF max (x,y,z) : MRI voxels(145.793, 154.882, 144.857) MRI
coordinates(145.2, 144.7, 102.3)

ID(2.2.5.) Int(30%) Expv(27241) EMG1(- -) EMG2(- -) EMG3(- -) EMG4(- -) EMG5(- -) EMG6(- -) User
Response(500.0) EF max (x,y,z) : MRI voxels(144.613, 150.252, 146.052) MRI coord(140.9, 145.9,
103.4)

ID(2.2.6.) Int(30%) Expv(27241) EMG1(149.6uV, 2.3ms) EMG2(- -) EMG3(- -) EMG4(- -) EMG5(- -)
EMG6(- -) User Response(750.0) EF max (x,y,z) : MRI voxels(144.404, 144.32, 147.297) MRI
coord(135.3, 147.1, 103.6)

ID(2.2.7.) Int(30%) Expv(32638) EMG1(- -) EMG2(- -) EMG3(- -) EMG4(- -) EMG5(120.2uV, 8.7ms)
EMG6(- -) User Response(1000.0) EF max (x,y,z) : MRI voxels(142.209, 138.474, 148.391) MRI
coord(129.8, 148.2, 105.7)

ID(2.2.8.) Int(30%) Expv(32638) EMG1(- -) EMG2(106.9uV, 36.3ms) EMG3(- -) EMG4(- -) EMG5(- -)
EMG6(- -) User Response(1500.0) EF max (x,y,z) : MRI voxels(163.995, 157.379, 142.919) MRI
coord(147.5, 142.7, 85.3)

Peeling depth 30 mm

ID(2.2.1.) Int(30%) Expv(10922) EMG1(- -) EMG2(- -) EMG3(278.1uV, 4.7ms) EMG4(- -) EMG5(- -)
EMG6(- -) User Response(-) EF max (x,y,z) : MRI voxels(151.108, 163.093, 120.256) MRI
coord(152.9, 120.1, 97.4)

ID(2.2.2.) Int(30%) Expv(128) EMG1(- -) EMG2(- -) EMG3(- -) EMG4(- -) EMG5(- -) EMG6(- -) User
Response(40.0) EF max (x,y,z) : MRI voxels(150.441, 160.107, 122.058) MRI coord(150.1, 121.9,
98.0)

ID(2.2.3.) Int(30%) Expv(10922) EMG1(- -) EMG2(- -) EMG3(- -) EMG4(- -) EMG5(- -) EMG6(- -) User
Response(50.0) EF max (x,y,z) : MRI voxels(148.918, 155.074, 124.479) MRI coord(145.4, 124.3,
99.4)

ID(2.2.4.) Int(30%) Expv(10922) EMG1(- -) EMG2(201.4uV, 25.7ms) EMG3(- -) EMG4(- -) EMG5(- -)
EMG6(- -) User Response(250.0) EF max (x,y,z) : MRI voxels(148.531, 149.074, 126.633) MRI
coord(139.7, 126.5, 99.8)

ID(2.2.5.) Int(30%) Expv(27241) EMG1(- -) EMG2(- -) EMG3(- -) EMG4(- -) EMG5(- -) EMG6(- -) User
Response(500.0) EF max (x,y,z) : MRI voxels(148.786, 145.445, 127.564) MRI coord(136.3, 127.4,
99.5)

ID(2.2.6.) Int(30%) Expv(27241) EMG1(149.6uV, 2.3ms) EMG2(- -) EMG3(- -) EMG4(- -) EMG5(- -)
EMG6(- -) User Response(750.0) EF max (x,y,z) : MRI voxels(147.808, 140.85, 128.414) MRI
coord(132.0, 128.3, 100.4)

ID(2.2.7.) Int(30%) Expv(32638) EMG1(- -) EMG2(- -) EMG3(- -) EMG4(- -) EMG5(120.2uV, 8.7ms)
EMG6(- -) User Response(1000.0) EF max (x,y,z) : MRI voxels(146.053, 136.31, 128.998) MRI
coord(127.8, 128.8, 102.1)

ID(2.2.8.) Int(30%) Expv(32638) EMG1(- -) EMG2(106.9uV, 36.3ms) EMG3(- -) EMG4(- -) EMG5(- -)
EMG6(- -) User Response(1500.0) EF max (x,y,z) : MRI voxels(165.059, 150.71, 125.195) MRI
coord(141.3, 125.1, 84.3)

```



## Appendix F: Electric field calculation

The calculation of the electric field (E-field) within the brain is a central feature of the Nexstim NBS. This feature shows the intracranial electric field superimposed on the subject's anatomical MR images.

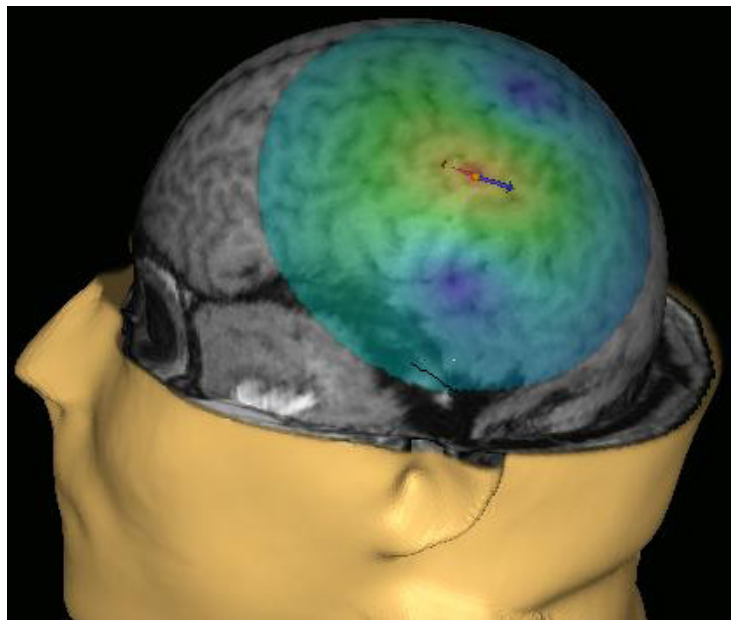
The electric field induced in the brain is the most important physical quantity in magnetic stimulation. The Nexstim NBS helps to predict the exact parts of the cerebral cortex that the stimulation actually reaches. Thereby, you can accurately target the stimulation into the examined cortical area.

The electric field calculation has the following benefits:

- The same brain areas can be stimulated with similar parameters in different subjects.
- Visualization of the cortex together with the stimulating field in 3D offers interactive ways to:
  - target the stimuli to map the selected positions in the cortex
  - maintain the stimulation at the right spot.

### Electric field visualization

See Figure 179 for how the Nexstim NBS illustrates the electric field reaching the cortex of a subject.



**Fig. 179.** Visualization of the electric field induced in the brain

When a stimulus sequence is active, the electric field is visualized in real-time on the Nexstim NBS user interface. The maximum strength of the electric field at the selected peeling depth is visualized in **Info Panel**, and the strength of the electric field at the desired point of the head can be seen by pinpointing it with the crosshair.

The visualization of electric field is managed in the **Settings**-tab. For more information, see Chapter 5.13 “Settings-tab” on page 76.

### Calculation details

The location of the strongest intracranial stimulation field depends on the following:

- the shape of the stimulating coil
- the location of the coil
- distance of the coil from the scalp
- the orientation of the coil with respect to the subject’s head.

---

#### NOTE:

Even slight tilting of the coil over the scalp may noticeably change the location and strength of the intracranial neuronal activation. It is therefore important to locate the coil with respect to anatomic structures of the brain.

---

The Nexstim NBS calculation of the intracranial stimulation field takes the following into account:

- The exact shape of the copper spirals inside the coil
- The exact 3D location and orientation of the coil
- The inductance of the coil and the stimulator
- The stimulator charging voltage
- Head shape details.

The Nexstim NBS uses an approximation of the head shape. The NBS software constructs a spherical conductor model from the MR images of the patient. The model is based on a multi-layer sphere model familiar from biomagnetism studies. The size and origin of the spherical conductor model change with the coil position to best match the local head shape.

For more information on the related literature, see references 1. and 2. in “References” on page 245.



## **Electric field direction**

The stimulation coil should optimally be positioned so that the direction of the electric field is perpendicular to the sulcus of the stimulated area. A two-way red/blue arrow on the cortex illustrates the stronger direction of the stimulation as a red arrow, and the weaker direction as a blue arrow.

---

### **NOTE:**

While the electric field calculation gives important information of the stimulating field, the results are always only indicative. The calculation of the intracranial electric field must not be used as the sole basis for any clinical decisions.

The cerebral cortex and nerve cells have complicated shapes, and the location of maximal excitation depends on the direction and characteristics of the electric field induced.

---



## References

1. *Annals of Biomedical Engineering*. Ravazzani et al. 24:606-616, 1996.
2. *Modeling of the stimulating field generation in TMS*. Ruohonen J, Ilmoniemi RJ. *Electroencephalography and clinical Neurophysiology Supp.* 51:30-40 (1999).
3. *Safety, ethical considerations, and application guidelines for the use of transcranial magnetic stimulation in clinical practice and research*. Rossi S, Hallett M, Rossini PM, Pascual-Leone A; Safety of TMS Consensus Group. *Clin Neuropsychiol.* 2009 Dec; 120(12):2008-39.
4. *Nexstim NBS DICOM Conformance Statement for DICOM Export*

